

201 00BU

Building Construction

Christian Meuli, Karl Wehrle,
Heini Müller, Heini Pfiffner



SKAT



201-00BU-17076

Building Construction

Christian Meuli, Karl Wehrle,
Heini Müller, Heini Pfiffner

LIBRARY IRC
PO Box 93190, 2509 AD THE HAGUE
Tel.: +31 70 30 689 80
Fax: +31 70 35 899 64

BARCODE: 17076
LO: 201 00 Bu

SKAT



Contents

1. Introduction	1
2. Basic Information and Selection Criteria of Building Materials	3
2.0 General remarks	3
2.1 Stones	3
2.1.0 General	3
2.1.1 Classification	3
2.1.2 Selection	4
2.1.3 Testing	4
2.2 Gravel, sand, silt and clay	4
2.2.0 General remarks	4
2.2.1 Characteristics	4
2.2.2 Testing of sand and gravel	5
2.3 Cement	8
2.3.0 General	8
2.3.1 Hydration	8
2.3.2 Density, volume and mass	8
2.3.3 Storage of cement	8
2.4 Other binders	9
2.4.0 General	9
2.4.1 Pozzolanas	9
2.4.2 Limes	10
2.5 Burned bricks	10
2.5.0 General	10
2.5.1 Bricks	10
2.5.2 Quality control	11
2.6 Concrete blocks	11
2.6.0 General	11
2.6.1 Solid and hollow concrete block	11
2.6.2 Production process	12
2.6.3 Construction	12
2.6.4 Quality control	12
2.7 Wood and timber	12
2.7.0 General	12
2.7.1 Growth characteristics	13
2.7.2 Types and properties of timber	13
2.7.3 Timber preservation and seasoning	14
2.8 Bamboo	15
2.8.0 General	15
2.8.1 Application of bamboo in a water supply system	15
2.8.2 Advantages and disadvantages of bamboo	16

3.	Site Management	17
3.0	General	17
3.1	Preliminaries on site	17
3.1.0	General	17
3.1.1	Setting up a work camp	18
3.1.2	Work planning	18
3.2	Site Management	18
3.2.0	General	18
3.2.1	Preparation before construction	19
3.2.2	Implementation	19
3.2.3	Reporting	20
3.3	Setting out	20
3.3.0	General	20
3.3.1	Measuring of distances	20
3.3.2	Setting out of angles	20
3.3.3	Setting out of levels	21
3.3.4	Setting out of buildings	21
4.	Excavation and Backfilling	23
4.0	General	23
4.1	For trenches	23
4.1.0	General	23
4.1.1	Permissible slope	23
4.1.2	Boundary rods	24
4.1.3	Depth of the trenches	24
4.1.4	Width of the trench	26
4.1.5	Trench strutting	26
4.1.6	Backfilling	28
4.2	At tank sites	29
4.2.0	General	29
5.	Foundation	31
5.0	General	31
5.1	Types of foundations at water supply structures	31
5.1.0	General	31
5.1.1	Bearing capacity	31
5.1.2	Size of foundation	32
5.1.3	Strip foundation	32
5.1.4	Slab foundation	32
5.1.5	General rules for foundation construction	32
5.2	Special foundations	34
5.2.0	General	34
5.2.1	Foundation on uneven ground	34
5.2.2	Foundation on steep slopes	34
6.	Masonry Work	35
6.0	General	35
6.1	Cement mortar	35
6.1.0	General	35
6.1.1	Mortar mixtures	35
6.1.2	Recommended mortar and plaster mixtures and their use	36

6.2	Pointing, plastering and topping	37
6.2.0	General	37
6.2.1	Pointing	37
6.2.2	Plastering	37
6.2.3	Topping	39
6.3	Brick and block masonry	40
6.3.0	General	40
6.3.1	Brick bonding	40
6.3.2	Cement block bonding	41
6.3.3	General rules for bricks and cement block masonry (cement hollow blocks)	41
6.4.1	Stone shaping	43
6.4	Stone masonry	43
6.4.0	General	43
6.4.2	Stone masonry	45
7.	Concrete Work	47
7.0	General	47
7.1	Concrete	47
7.1.0	General	47
7.1.1	Aggregates	47
7.1.2	Water	48
7.1.3	Water-cement ratio	48
7.1.4	Concrete mixtures	48
7.2	Mixing and processing of concrete	49
7.2.0	General	49
7.2.1	Hand mixing	49
7.2.2	Machine mixing	50
7.2.3	Processing of concrete	50
7.3	Quality of concrete	51
7.3.0	General	51
7.3.1	Cube test	51
7.3.2	Rebound hammer test	51
7.4	Reinforced concrete	52
7.4.0	General	52
7.4.1	Reinforcement	52
7.4.2	Form work	53
7.4.3	Precast concrete	53
8.	Construction of a Masonry Tank	55
8.1.0	General	55
8.1.1	Site preparation	55
8.1.2	Construction	55
8.1.3	Finishing work	56
	Reference Books	57

1. Introduction

The aim of this manual is to describe the variety of work as well as to provide a survey of the types of materials used in rural water supply construction. Some of the materials and their use are only briefly described. This manual refers in many chapters to the existing sourcebook on ***Appropriate Building Materials***, a co-production of SKAT, IT and Gate published in 1988; third revised edition 1993.

In general a water supply project has to be planned and constructed with the highest possible quality of materials and craftsmanship.

The following few key factors determine the long-term sustainability of water supply systems:

A. Water supply system

The key factors are: simplicity of design, availability of local materials, quality of construction, reliability of supply, acceptability of supply standards, operation and maintenance friendliness.

B. Villages capability

The key factors are: to adjust to the required

social changes, to make effective use of the system, to manage the system, to maintain the system, to pay for operation and maintenance (ability and willingness).

C. Government interest and capability

The key factors are: to provide the legal base for operation and maintenance (so that for example sanctions can be applied), to enable repairs which go beyond the villagers' capacity, to provide long-term controlling and guidance support.

D. Protection of environment

The key factors are: political, economic, physical and natural (e.g. deforestation = soil erosion = decreased ground water)

If these factors are well considered a water supply scheme should last for 30 to 50 years without requiring major repairs or renovation. This manual provides the information needed to achieve the required high quality of construction, and thereby to create a long lasting and reliable water supply.



2. Basic Information and Selection Criteria of Building Materials

2.0 General remarks

Each construction site requires specific building materials. Some of the material may be available locally, while other material has to be organized from far away. Available natural and local materials are of different characteristics and quality. Therefore, knowledge of how to select the best material and how to make efficient and economical use of the materials is essential.

2.1 Stones

2.1.0 General

Natural stone is perhaps the oldest, most abundant and most durable "ready-made" building material, and is found predominantly in hilly areas.

Stones for construction purposes like the building of structures, are prepared by breaking raw pieces from large rocks or stones into stones of the appropriate size. Various types of stones with specific characteristics are used in the construction of water supply systems.

2.1.1 Classification

In the following section the most common stones used for construction are described: igneous, sedimentary, and metamorphic stones.

a. Igneous stones

Volcanic in origin, they have been fused by heat and then cooled and crystallized. These hard stones have a very good compressive strength and are compact. When working with these stones keep in mind that because of the hardness stone shaping of igneous rocks is very difficult. The principal stones in this class are granites and basalt.

Igneous stones can be used for all water supply

related masonry work like:

- Catchments
- Chambers
- Storage tanks
- Standpipes
- Surrounding work
- Dry walls

b. Sedimentary stones

These are formed by the weathering of land masses and the removal of the particles by water and wind and the deposition over thousands of years in lakes or the sea. The deposited grains are united by some cementitious material. The sedimentary stones are comparatively weak stones. They are less compact (porous), and where exposed to the weather often not of long durability. Whenever sedimentary stones are used for construction purposes they have to be checked for durability. The principal stones in this class are sandstone and limestones.

Sedimentary stones can be used for:

- Catchments (testing for durability required)
- Chambers (testing required)
- Storage tanks (testing required)
- Standpipes (testing required)
- Surrounding work
- Dry walls

c. Metamorphic stones

These stones are sedimentary or igneous in origin, but have undergone a change caused by immense heat and pressure to such an extent that they assume a new structure and form new materials. The principal stones in this class are slates (derived from clay), quartzites (from sandstone) and marble (from limestone).

Metamorphic stones can be used for:

- Catchments (testing for durability required)

- Chambers
- Storage tanks (testing for durability required)
- Standpipes
- Surrounding work
- Dry walls

2.1.2 Selection

In general, the stones for construction should be collected at the usual places where the villagers find their building materials. If stones are used for local buildings their quality can be checked at those existing buildings. Stones used for tank construction should always be tested as described in the following Chapter 2.1.3 Testing. If there is no long term experience of building with the local stone, the testing of the stone's quality and durability becomes very important.

If stones are not used for the local buildings, the collection of the stones can be done in the following ways:

a. Collecting stones at the surface

If stones are collected at the surface they generally need a lot of shaping to obtain the required shape for masonry work. Therefore this is in general not a economical way of preparing the stones for construction.

b. Breaking (cutting) rocks at the surface

If surface rocks can be cut in pieces it is the best way to obtain stones for the construction. The cutting should be done in such a way that as little as possible shaping is necessary after-wards.

Remark:

Igneous and sedimentary rocks are widespread and are the most common building stones used. Whenever natural stones are to be used for construction work the durability has to be tested first. However, in general the local masons will know the best quality stones available, and this knowledge should be considered and used.

2.1.3 Testing

A simple testing procedure can be done in the field as described below. More detailed testing has to be done by a trained person. Internal or surface cracks in the stone can with time weaken a structure.

The quality of the stone can be assessed by striking the stone lightly with a hammer. A bell-like high sound indicates good quality, and a dull low sound bad quality. This test is very important when using sedimentary rocks.

Another test can be done by laying the stone in water, take it out after one day, let it dry out, clean it from organic matter and put it back into the water again. Continue with this procedure for at least two weeks. If the stone does not break into pieces or develop cracks, it is considered adequate for construction purposes.

2.2 Gravel, sand, silt and clay

2.2.0 General remarks

Sand and gravel are the types of aggregates needed for the manufacture of concrete, plaster or mortar. Aggregates should consist of clean, hard, strong and durable particles. Sand and gravel used in connection with cement should be not polluted by any leaves, wood, grass, humus or clay, because this negatively influences the quality of the product. The method of crushing stones to obtain gravel for construction is sometimes the only solution to get the raw material. River sand does normally not need further treatment before using.

Silt and clay are used only secondarily at water supply constructions, for example to cover and therefore watertighten the spring catchment, or to seal the foundation of a catchment.

2.2.1 Characteristics

To obtain good quality concrete or mortar it is essential to have aggregates which meet the requirements. Following are described the characteristics of the most frequently used aggregates:

a. Gravel

Coarse pieces of rocks like granite, lime, marble, etc. of any shape (round, flat or angular). Gravel forms the skeleton of the soil and limits its capillarity and shrinkage.

The size of the particles are 2mm to 60mm.

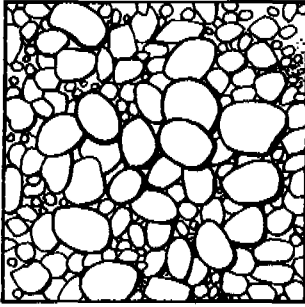

Gravel is used for:

- concrete
- permeable construction at catchments
- drainage
- levelling

b. Sand

Particles mainly comprising of silica or quartz; beach sand contains calcium carbonate (shell fragments). Sand grains lack cohesion in the presence of water, and limit swelling and shrinkage.

The size of the particles are 0.06mm to 2mm (this is the smallest grain size that can be discerned by the naked eye).

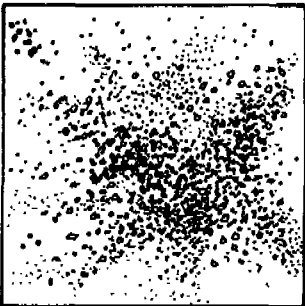

Sand is used for:

- concrete
- mortar
- pipe filling
- levelling

c. Silt

Physically and chemically the same as sand, only much finer. Silt gives soil stability by increasing

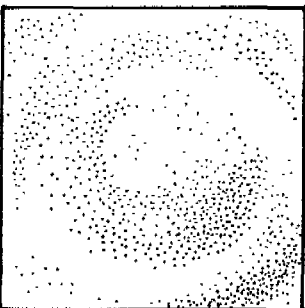

its natural friction, and holds together when wet and compressed.

The size of the particles is 0.002mm to 0.06mm. Silt should not be used for concrete or mortar because silt can interfere with the bond between cement and aggregate, and it requires more water (large specific surface).

d. Clay

Clay results from chemical weathering of rocks, mainly silicates. The hydrated aluminosilicate particles are thin plates of extremely great specific surface area, causing strong cohesion in the presence of water, but also causing excessive swelling and shrinkage.

The size of the particles is smaller than 0.002mm.

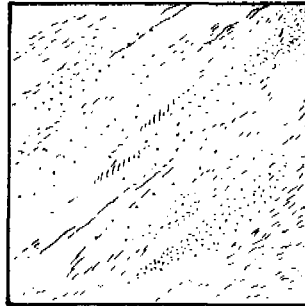

Clay is used for:

- Clay is hardly used for water supply construction, however it may be useful to improve the watertightness of a spring catchment.
- As raw material clay is used for the fabrication of bricks

2.2.2 Testing of sand and gravel

To guarantee the quality of the structures it is very important to ensure the required quality of the raw materials. The sand and gravel, for example, must be free of clay or organic matters. Clay and organic matters reduce the quality of binding in cement, and will swell and shrink, therefore causing cracks in the structure. There are several different field and laboratory tests described in the Manual on **Appropriate Building Materials**, as well as in **Properties of Concrete** (Ref. 1 and 2). In the present manual only simple field testing is described.

a. Sieve analysis (grain size)

Most natural soils are mixtures of sand, silt and clay. The relative proportion of individual soil frac-

tion is determined by sieve analysis. Sieve analysis is the simple operation of dividing a sample of aggregate into fractions, each consisting of particles of the same size. In practice, each fraction contains particles between specific limits, these corresponding to the openings (apertures) of standard test sieves.

The test sieves used for concrete aggregate have square openings. Sieve sizes are designated by the nominal aperture size in millimetres.

Sieves smaller than 4mm (0.16in.) are normally made of wire cloth although, if required, this can be used up to 16mm (0.62in.). Coarse test sieves (4mm (0.16in.) and larger) are made of perforated mild steel plate.

All test sieves are mounted in frames which can nest. It is thus possible to place the sieves one above the other in order of size with the largest sieve at the top, and the material retained on each sieve after shaking represents the fraction of aggregate coarser than the sieve in question but finer than the sieve above.

The sieves used for concrete aggregate consist of a series in which the clear opening of any sieve is approximately one-half of the opening of the next larger sieve size.

Before the analysis is performed, the aggregate sample has to be air-dried in order to avoid lumps of fine particles being classified as large particles and also to prevent clogging of finer sieves. The international sieve sizes as well as the minimum weight of sample to be taken are as following:

Sieve Analysis

Project:	-----
Location of Project:	-----
Aggregate total sample weight	-----
Test No.	-----
Tested by:	-----
Date:	-----

Sieve size	Weight retained	Percentage retained	Cumulative percentage passing	Cumulative percentage retained
mm	g	%	%	%

Sieve sizes		Minimum weight of sample to be taken for sieving
mm	kg	
63	50	
50	35	
40	15	
28	5	
20	2	
14	1	
10	0.5	
6 or 5 or 3	0.2	

The actual sieving operation can be performed by hand, each sieve in turn being shaken until not more than a trace continues to pass. The movement should be backwards and forwards, sideways left and right, circular clockwise and anticlockwise, all these motions following one another so that every particle "has a chance" of passing through the sieve.

The results of a sieve analysis are best reported in a table form as shown below.

The results of a sieve analysis can be grasped much more easily if represented graphically, and for this reason grading charts are very helpful to use. By using a chart it is possible to see at a glance whether the grading of given sample conforms to that specified, or is too coarse or too fine. For more details on sieve analysis see Ref. 2.

1. If the tested sample is within this area, it can be used.
2. If the tested sample is within this area, coarse or fine sand has to be added.

b. Hand-test:

The hand filled with the aggregates to be tested is clenched and then opened again. If the material is clean it should not stick together in a lump. When the material is rubbed between the hands, the hands should remain almost clean. Otherwise the silt and foreign material has to be washed out by thorough rinsing with water.

c. Bottle-test:

A clear one litre bottle filled two-thirds with material and topped with water is shaken vigorously. Allow it to settle for half an hour. If the water is still dirty, and a sediment has settled on top of the sand of more than 4mm in height, the material needs to be considered for washing, depending on its use.

Grading curve 0 - 32 mm

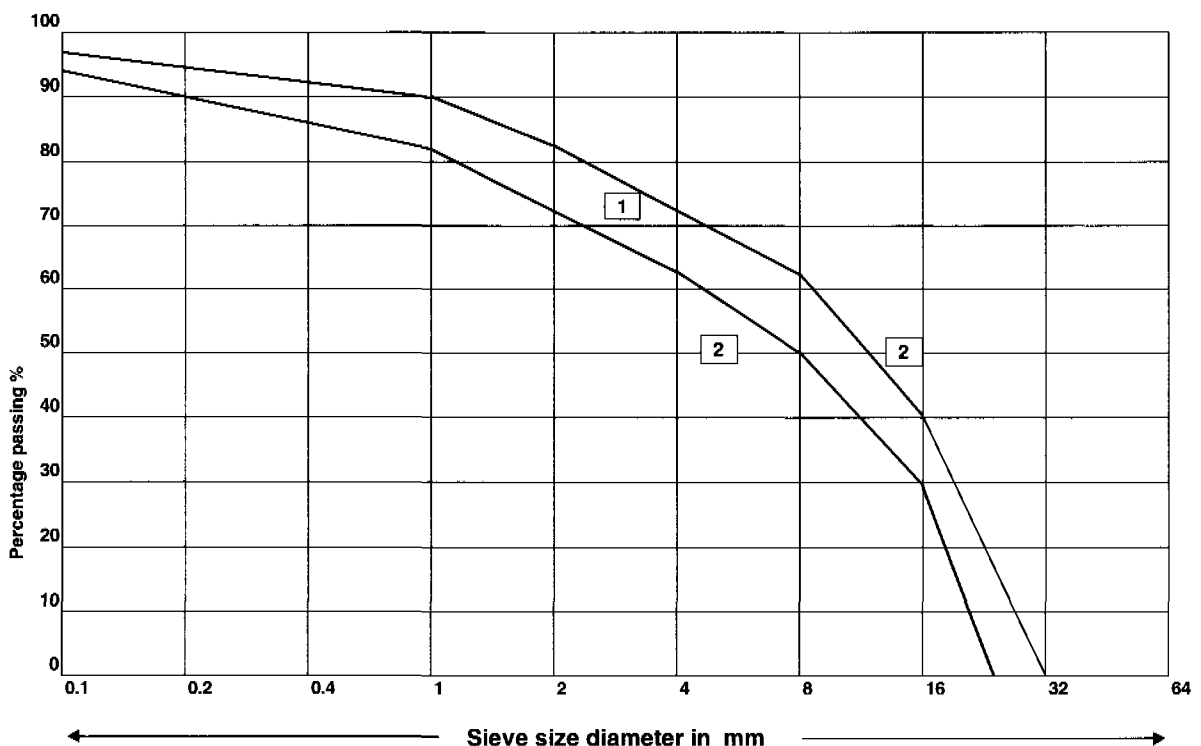

Remark:

It is very important to use material of the required quality. If the quality of local materials can not be clearly confirmed, materials of other areas should be investigated or an experienced person should be consulted.

2.3 Cement

2.3.0 General

Of the large variety of cements available today, ordinary Portland cement (OPC) is the most common, and usually the type referred to when speaking of cement. It is the fine, grey powder that can be mixed with sand, gravel and water to produce a strong and long lasting mortar or concrete. Cement is a hydraulic binder that can harden under water. Normally Portland cement is sold in 50 kg bags. When the adequate amount of water is added, it hardens after approximately 2 1/2 hours at a temperature of at least 5°C. After 28 days a good quality concrete mortar with 300 kg cement per 1 m³ has a compressive strength of up to 300 kg/cm². Cement is made of limestone (calcium carbonate) and clay (silica, alumina and iron oxide) that are ground and mixed with water to form a slurry. This raw materials is burned at the temperature of 1300°–1400°C in a kiln. The burnt cement (clinker) is then broken, mixed with a small percentage (in general 3%) of gypsum and then ground to a very fine powder. The finer it is ground, the higher the rate of the setting and strength development.

2.3.1 Hydration

The Portland cements are classified as hydraulic cements for the reason that they have the property of hardening under water. The hardening process involves the reaction between the cement and the water. This type of chemical reaction is known as hydration. Hydration of cement is divided into two processes called setting and hardening. When water is added to cement a chemical reaction takes place. After a period of 1/2 to 2 hours (depending on the air temperature) the setting time starts and lasts 6 to 8 hours. Already during the setting time the cement starts to harden. Theoretically the hardening time of Portland cement is unlimited. In practice the expected strength of the cement construction is reached after 25–30 days.

During the hardening process the cement tends to dry out too quickly, particularly in dry climatic conditions. For this reason curing (see Chapter 7.2.3) of cement-based products is required for at least two weeks.

2.3.2 Density, volume and mass

The cement leaves the factory in bags containing 40 litres (or 40 dm³). On the scale this shows 50 kg.

Therefore, cement has the following specific natures.

Density:

$$50 \text{ kg} \div 40 \text{ dm}^3 = 1.25 \text{ kg/dm}^3$$

Volume:

$$50 \text{ kg} \div 1.25 \text{ kg/dm}^3 = 40 \text{ dm}^3 \text{ or litres}$$

Mass:

$$1.25 \text{ kg/dm}^3 \times 40 \text{ dm}^3 = 50 \text{ kg}$$

These figures can be used for exact calculations of the different mortar mixtures and concrete mixtures.

2.3.3 Storage of cement

In general cement should not be stored over long periods of time (more than two months). Moisture destroys cement, therefore it must be stored dry. If the cement contains lumps it is a clear sign that it has been exposed to moisture. A storing place with a secure roof and good ventilation is required. It is recommended to use a separate store room. To avoid rising damp do not store the cement directly on the floor, but for instance on timber pallets. Avoid contact of the cement bags with outer walls and floor. Walls and floors could be a source of moisture. In addition proper ventilation is prevented when the cement bags lay directly on the floor or against a wall. The cement stack should not be more than 10 bags high.

Good

Storing on timber pallets and no contact with outer wall.

Wrong

Storing directly on the floor and at the outer wall
Cement should not be kept longer than 2 months.

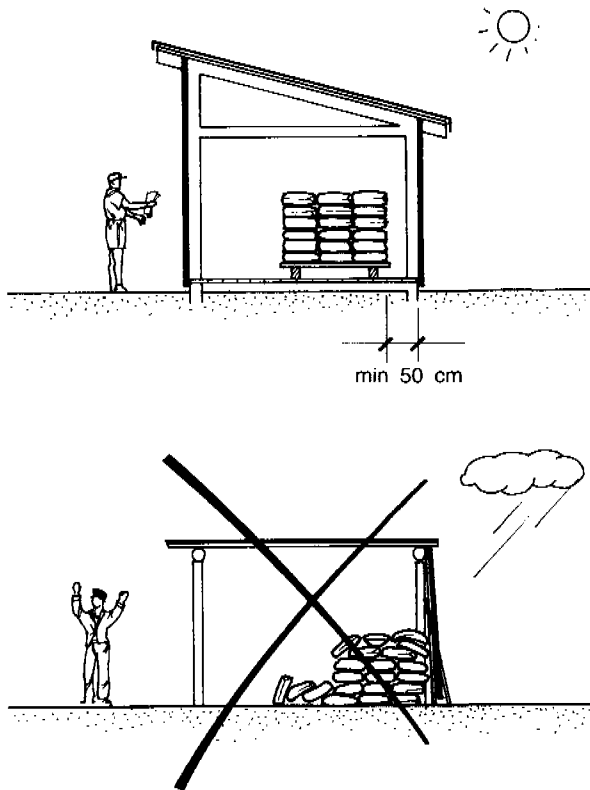

This is especially important in humid climates. The old stock should always be used before the new one. Cement can be expected to lose from its potential strength because of storage time as follows:

~ 20 %	after	3	months
~ 30 %	after	6	months
~ 40 %	after	12	months (1 year)
~ 50 %	after	24	months (2 years)

Remark:

Proper storage, as well as handling with care is very important when working with cement. If the cement has lumps, the bags are hard, or the quality of cement is doubtful in any way, it should not be used anymore. Cement with only a few lumps may still contain some quantities which can be used. In this case it should be sieved through a 0.5mm sieve and used for less sophisticated construction work like foundation or lean concrete work.

2.4 Other binders

2.4.0 General

Lime and lime-pozzolanas are other common binders in construction work because of their low production costs and compatibility with traditional

building materials such as earth. They are, however, unsuitable for reinforced concrete or high or medium strength concrete. Pozzolanas can also be blended with Portland cement to give a cement with similar properties to Portland cement provided that replacement rates are kept to below 20 or 30%. Lime by itself can be classified as hydraulic or non-hydraulic. In general, for reasons given below, the use of non-hydraulic lime as a cement is not recommended for use in any part of a water supply system. Lime-pozzolana cement or hydraulic lime could be used in some cases provided the limitations of these materials are known about. Portland-pozzolana cement can be used in the same way as portland cement and there could even be advantages in using this cement in certain applications, as explained below.

2.4.1 Pozzolanas

Pozzolans are siliceous or siliceous together with aluminous materials which in themselves possess little or no cementitious value but react chemically, when in a finely divided form, with calcium hydroxide (lime) in the presence of water to give a solid material similar to that produced by hardening of Portland cement. When pozzolanas are mixed with Portland cement they react with the excess lime which is produced when Portland cement hardens. Examples of pozzolanas are pulverized fuel ash from coal-burning power stations, finely ground burnt clay, certain types of volcanic ash and ash produced by burning rice husk.

With Portland-pozzolana cements the addition of pozzolanic material in general increases the water demand. This may sometimes necessitate an increase in the cement content of the mix and there is also an increase in the risk of cracking caused by drying shrinkage. The main advantage of adding pozzolana to Portland cement is that the alkalinity of the cement matrix is reduced. Thus there is less likelihood of an alkali-silica reaction with aggregate susceptible to this reaction, and mortars and concrete made with this cement are more resistant to acidic environments.

There is little point in using lime-pozzolana cements for any part of the water supply system. Not only are the setting and hardening times longer compared with Portland cement but also there is a need to test the materials often to ensure that they are

of a good and consistent quality. Variation in properties of lime and pozzolanas is a potential source of trouble unless they come from one or two reliable suppliers and have been mixed together well. In contrast the quality of Portland cement should be assured by the supplier.

2.4.2 Limes

Hydraulic lime

Hydraulic lime is produced from limestone containing a proportion of clay which is burned in a kiln and then hydrated with a minimum quantity of water. This lime reacts like non-hydraulic lime with carbon dioxide in the air, and also with water in a similar way to Portland cement. Hydraulic limes have the ability to harden under water. If the limestone has a sizable proportion of clay and is burned to an increased temperature (100½C or so more than with non-hydraulic lime) the lime begins to resemble Portland cement and is classified as “eminently hydraulic”. With less clay and a lower burning temperature the lime would be only moderately or mildly hydraulic. Only eminently hydraulic lime might have some potential for use in a water supply system, but as with lime-pozzolana cements there would be no advantage in doing so and greater attention would need to be paid to quality control than when using Portland cement. Before the use of Portland cement became widespread early in this century, eminently hydraulic lime was used for structures in contact with water, usually in combination with pozzolanic material.

Non-hydraulic lime

Non-hydraulic lime is produced by burning almost pure calcium carbonate limestone in a kiln and hydrating the resulting quicklime with water. It is not resistant to water when it is constantly exposed to it and in addition it makes the water excessively alkaline (pH 11-12.5) and possibly cloudy. Lime is attacked particularly by acidic water with a pH below 6.0. The use of non-hydraulic lime by itself is not recommended for any parts of a water supply system.

Conclusion

Cement is the only binder that fulfills the quality requirements for water supply schemes.

2.5 Burned bricks

2.5.0 General

Bricks can be used for many structures at village water supply systems. Today many different methods of brick making exist. The construction of a water supply scheme requires high quality materials, therefore this manual refers only to high quality burned bricks. For more detailed information about brick refer to *Appropriate Building Materials* (Ref.1).

Bricks can be used for all water supply related masonry work like:

- Catchment chambers
- Storage tanks
- Standpipes
- Surrounding work
- Pumphouses

Advantages of bricks

- No dimension and design limitation
- Equal dimension
- Easy to transport
- Fast building
- Local material
- High quality if from professional production
- Job creation (Building industries)

Disadvantages of bricks

- Costly
- May not be locally available
- Locally made bricks can often not be used for water tanks because they lack the required quality (always testing required)
- Need of firing with great use of scarce raw materials (wood, ore, fuel)
- High percentage of breakage, leading to waste

2.5.1 Bricks

In general the raw material for brick manufacturing is clay. If the clay is too fine, the bricks have a high shrinkage rate and tend to develop cracks during the drying process. If the clay contains too much sand it will cause the bricks to loose strength.

The manufacturing process of burned bricks includes:

- mining
- mixing
- forming
- drying
- firing
- use in building construction

Factory made bricks are in general of constant uniformity and strength. Locally made bricks are often of uneven dimensions and vary in strength, and therefore are not always useful for the construction work at water supplies.

2.5.2 Quality control

The quality requirements of locally burned bricks can be checked as follows:

a. With a hammer

As explained in Chapter 2.1.3 (Testing for stones) cracks inside the bricks will be recognized when there is a low dull sound when struck with a hammer. Good quality bricks will give a high bell-like sound when struck with a hammer.

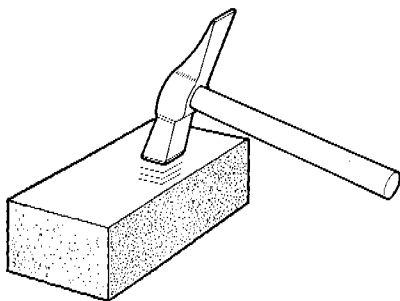

b. Dropping the brick

A good quality brick should not break or crack after being dropped from 1 m of height. Always test with the hammer after the brick has been dropped, to ensure that there are no cracks inside.

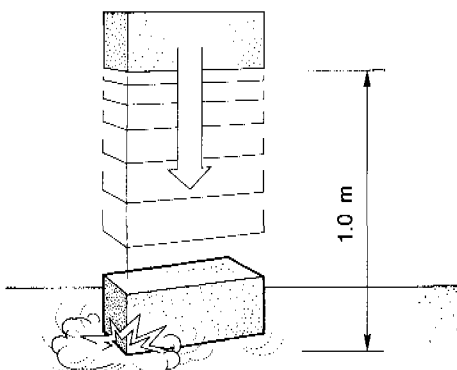

2.6 Concrete blocks

2.6.0 General

There exist several types of concrete blocks, the most common being solid block, cellular block, hollow block, and interlocking block. Concrete block construction is gaining importance in many countries, even in drinking water system construction. It is a valid alternative to fired clay bricks, concrete, stone, timber and other common construction materials, provided the raw materials are available locally and they are of good quality and economically viable.

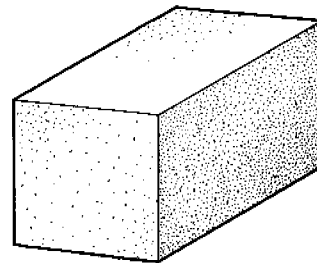

2.6.1 Solid and hollow concrete block

Both type of blocks are suitable for the construction of certain parts of a water supply system.

Solid concrete blocks:

For a circular type of water tank it is recommended to use solid concrete blocks. However, horizontal steel rod reinforcement is recommended, which is laid into the different mortar layers.

Hollow concrete blocks:

This type of concrete block can be used for all kinds of construction. One advantage is that the hollows can be filled with concrete and steel bars for reinforcement of the construction.

However, it is advised not to use hollow concrete blocks for water tank construction since the quality of the concrete blocks can be different. For other parts of the water supply system, assuming that the ingredients and workmanship of the hollow concrete blocks are of good quality, the use of hollow concrete blocks can be as good as any other relevant building material.

Hollow concrete blocks can be used for water supply schemes for the following structures:

- Catchments
- Standposts
- Dry walls
- Operation chambers
- Break pressure tanks
- Pumphouse

The main characteristics of the common types of hollow concrete blocks are:

- high compressive strength, resistance to weathering, impact and abrasion
- low tensile strength (but can be overcome with steel reinforcement and filling with concrete)
- capability of being moulded into components of any shapes
- good fire resistance up to 400°C

The main problems, particularly with regard to developing countries, are:

- the need for relatively large amount of cement
- the need for relatively large amount of clean water for mixing and curing, which can be a serious problem in dry regions;
- the need for special knowledge and experience in the production process as well as in the construction process
- the risk of deterioration through sulfates in the soil or water to which the concrete block is exposed

2.6.2 Production process

The ingredients of concrete blocks can be of very different types and qualities, not only depending on their local availability, but also on the desired strength properties of the blocks. Therefore it is not possible to give detailed recommendations on material and mix proportions, other than general guidelines.

The raw material for the production of concrete blocks consists of cement, sand and water. The correct sand-cement ratio must be found by trials with different ratios (4:1, 6:1, 8:1, etc.).

Determining the water-cement ratio needs special experience from the producer. Only trials will give the correct ratio, and depends strongly on the moisture content of the aggregates.

Batching and mixing, moulding, curing and storing is the usual production procedure for the concrete blocks.

2.6.3 Construction

Concrete blocks must be dried out thoroughly before use, otherwise drying will continue after building the wall and shrinkage cracks may develop. Mortars used for bedding should not be too rich in cement. It is important that the strength of the mortar does not exceed that of the blocks, so that the joints can absorb a limited amount of movement, preventing the blocks from cracking.

2.6.4 Quality control

Manually produced concrete blocks are not likely to attain the superior qualities that are achieved by mechanized production. It is therefore advisable to use mechanized produced concrete blocks for the construction of any type of building for a water supply system. Minimal quality requirements of concrete blocks are checked the same way as for burned bricks, see Chapter 2.5.2

Advantages of concrete blocks:

- equal dimensions
- fast building
- local production possible
- low production cost
- relatively easy to produce
- environment friendly

Disadvantages of concrete blocks:

- transportation cost if locally not available
- depends on a reliable cement supply
- raw material quality not always consistent
- needs a relatively long curing time (28 days)

2.7 Wood and timber

2.7.0 General

Timber is not only one of the oldest building materials, but has remained until today the most versatile one. However, timber is an extremely complex material, available in great varieties and forms, with greatly differing properties between regions.

Timber is basically a renewable material. Nevertheless, there is an universal concern about the rapid depletion of forests and the great environmental, climatic and economic disaster that follows. Although construction timber represents only a small fraction of the timber harvested, it should be used thriftily and wastage should be minimized. Also, re-forestation programs should be promoted.

2.7.1 Growth characteristics

The cross section of a trunk or branch reveals a number of concentric rings. The trunk thickness increases by the addition of new rings, usually one ring each year.

The early wood (spring-wood) formed during the growth period has larger cells, while in the dry season the late wood (summer-wood) grows more slowly, has thicker cell walls and smaller apertures, forming a narrower, denser and darker ring, which gives the tree structural strength.

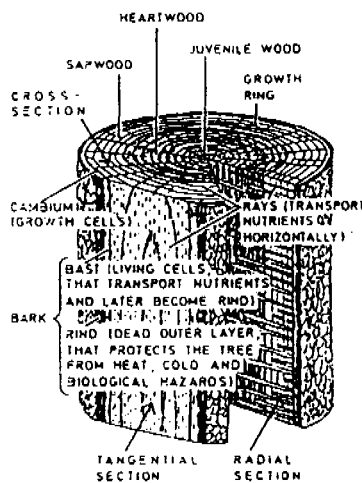

Structure of a tree trunk (hard wood and soft wood)

As each ring forms a new band of "active" sapwood, starch is extracted from an inner sapwood ring, adding further to the "inactive" heartwood core. Mechanically there is hardly any difference between sapwood and heartwood, but sapwood is usually lighter in color and contains substances (e.g. starch, sugar, water) which attract fungi and some insects.

The slower the tree grows, the narrower are the growth rings, and the denser and stronger is the timber. Its resistance to biological hazards is also usually greater.

2.7.2 Types and properties of timber

Woods are classified as either hardwood or softwood. There are different methods of distinguishing these woods, but the most common method is that hardwood comes from broad leaved trees, in the tropics usually evergreen, in temperate zones usually deciduous (shedding their leaves annually). Softwood is generally from coniferous (cone-bearing) trees, commonly known as evergreens, and found mainly in temperate zones. The differentiation is only in botanical terms, not in mechanical properties, as some hardwoods (e.g. balsa) are much softer than most softwoods.

There are many other methods of classifying woods, and the definitions differ often between regions. For instance in West Africa the term "red wood" commonly refers to hard and strong timber and "white wood" refers to soft and weak timber. In other regions this terminology is not known, or is used in an other sense.

Timber categories

Timber for building construction can be divided into two or more categories according to the mechanical strength. Often one distinguishes between primary and secondary timber species.

- Primary timbers are generally slow-grown, aesthetically appealing hardwoods which have considerable natural resistance to biological attack, moisture, movement and distortion. As a result, they are expensive and in short supply.
- Secondary timber are mainly fast-grown species with low natural durability, however, with appropriate seasoning and preservative treatment, their physical properties and durability can be greatly improved. With the rising costs and diminishing supplies of primary timbers, the importance of using secondary species is rapidly increasing.

Sizing

When sizing structures, the bearing capacity of the timber at hand has to be taken into account. This should be done in consultation with the local norms and standards.

Sawn timber products

Sawn timber is cut mainly from older trees with large diameter trunks, in rectangular sections as

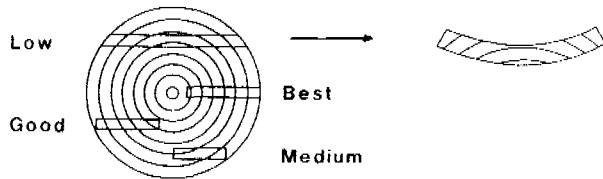

beams or boards. The part of the trunk from which they are cut and the slope of grain have great effect on the quality of the product. Therefore, when selecting timber, the direction of the grain has to be observed.

High quality boards are used for heavily stressed structural members, e.g. purlins and in trusses.

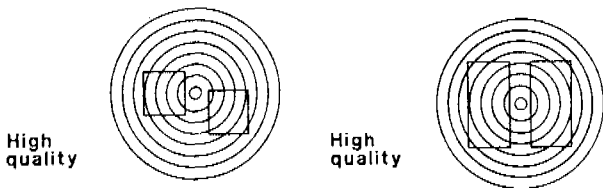

Low quality boards are used for wall plates etc.

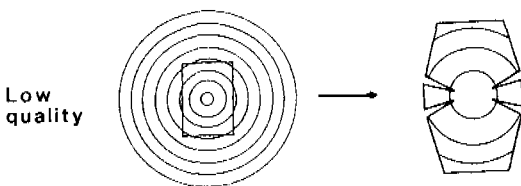

To make the best use out of a trunk, the cutting method has to be considered. The commonly known cutting types are illustrated in the figure below.

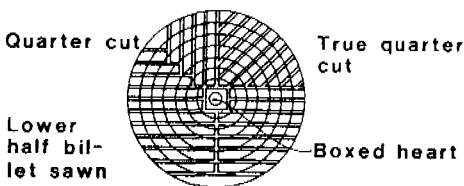

Selection of timber

For structural members which are under high stress, such as purlins and rafters and in trusses, the selection of timber is of great importance. Timber with cracks, knots or with grains that are not longitudinal should not be used. Such timber should only be used in situations with reduced stress, such as wall plates.

Cracks

During harvesting and transport cracks may occur. Such timber should be rejected. Cracks may also occur due to shrinkage which is

unavoidable. Such timber should be tolerated to a certain extent, but not used for heavily stressed parts of the structure.

Hidden cracks are also possible but very difficult to detect. This risk is considered within the safety factor in the sizing calculations. The strength of beams can be greatly reduced by knots, especially when located in the area of the greatest bending moment and in situations with tensile stress.

For example, a knot in the upper third of the beam height situated between the supporting points, reduces the strength of the beam by up to 35%. If the knot is situated at the lower side of the beam, the reduction is even up to 56%.

The weakening depends much on the growth characteristic of the knot, how well it is grown into the adjoining wood.

Direction of grain

The strength depends also on the direction of the grain. It should be longitudinal. If not, then the strength is drastically reduced.



Good



Bad

Seasoned timber

To avoid cracking and warping, only seasoned timber should be used.

2.7.3 Timber preservation and seasoning

Timber is a highly valuable and durable material. However it must be carefully selected. Also it must be used in a competent way to retain this durability. The following aspects are important in this respect:

- Timber which is cut in the non-growing time (winter) is more durable.
- Cambium parts should not be used.
- Proper seasoning prior to use.

Seasoning

Prior to the manufacturing of timber components the timber has to be properly seasoned. One reason is that during drying timber shrinks. The shrinkage varies according to the direction of the grain: radial shrinkage is about 8% from the green to the dry state; the tangential shrinkage is about 14 to 16%; in the longitudinal direction shrinkage can be neglected (0.1 to 0.2%). The use of unseasoned timber results in cracks and warping parts.

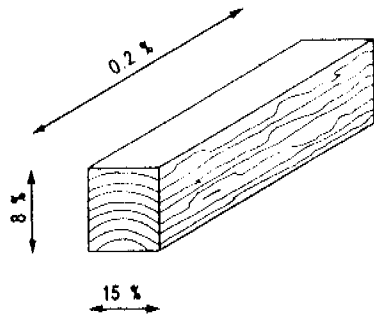

By proper seasoning the moisture content of timber is reduced to its equilibrium moisture content (between 8 and 20% by weight, depending on the timber species and climatic conditions). This process, which can take a few weeks to several months (depending on timber species and age, time of harvesting, climate, method of seasoning), makes the wood more resistant to biological decay, increases its strength, stiffness and dimensional stability.

Seasoning methods

Basically, three different methods of seasoning can be used:

- Air seasoning is done by stacking timber such that air can pass around every piece. Protection from rain and avoidance of contact with the ground are essential.
- Forced air drying is principally the same as air seasoning, but controls the rate of drying by stacking in an enclosed shed and using fans.

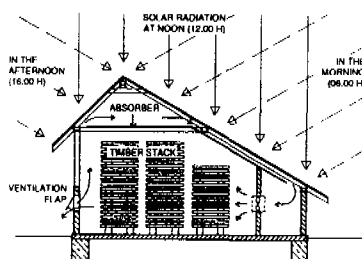
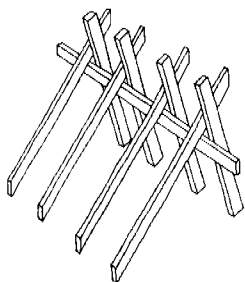

- Kiln drying achieves accelerated seasoning in closed chambers by heating and controlling air circulation and humidity, thus reducing the drying time by 50 to 75%, but incurring higher costs. An economic alternative is to use solar heated kilns.

Remark:

Seasoning time is greatly reduced if the timber is harvested in the non-growing season (winter) when the moisture content of the tree is low.

2.8 Bamboo

2.8.0 General

Bamboo is, as well as timber, one of the oldest building material and is still widely used today in many countries. The main area of distribution of bamboo is the tropics. Some robust species are also found in subtropical and temperate latitudes. Untreated bamboo deteriorates within 2 or 3 years, but with correct harvesting and preservative treatment, its life expectancy can increase about 4 times. The following factors must be considered in building with bamboo:

- protection from moisture
- access of air circulation
- avoidance of contact with soil
- only matured culms should be used

2.8.1 Application of bamboo in a water supply system

Bamboo as a building material can be used in the construction of a water supply system for the following work:

- bamboo reinforced structure, like standpost floor etc.
- for all kinds of shuttering work
- scaffolding
- temporary roofing
- fencing
- temporary pipes
- framing work

2.8.2 Advantages and disadvantages of bamboo

Advantages:

- in many regions bamboo is abundantly available
- easy handling
- no waste
- environment friendly (quick growing)
- good tensile strength

Disadvantages:

- bamboo has a relatively low durability
- easily attacked by biological agents
- predrilling is essential to avoid splitting
- bamboo is not fire resistant
- bamboo is becoming in many countries a rather expensive building material

3. Site Management

3.0 General

Before the construction of a water supply project can be started, there is a great deal of preparation work to be done in the office as well as in the field. For successful constructions this preparatory phase is very important. In this manual, only the technical aspects of preparing a construction site are described. Nevertheless a good planning and site organization can avoid many social problems too when the preparation work is carefully thought out and implemented. Most of the following comments are given under the assumption that at least some of the civil works are carried out with voluntary labour.

3.1 Preliminaries on site

3.1.0 General

Before any building materials are brought to the construction site the arrangements for proper storing needs to be organized. On a large construction site the required building material should be stored close to the structures where it will be needed to reduce the transportation within the construction site. All these places have to be shown to the villagers, so that when material arrives at the site before the construction crew is present the villagers can show the proper places to store the various materials.



Before the construction crew arrives at the site the necessary arrangements like accommodations, work time, required labour etc. have to be worked out.

If the villagers contribute with labour to the project, work like shaping stones, excavating trenches etc. has to be organized as well as checked by regular visits of a supervisor to the project site.

3.1.1 Setting up a work camp

The work camp at a rural water supply construction site should include a store room for building materials, dicing equipment as well as necessary small machines like vibrators, jackhammers etc.

3.1.2 Work planning

Before starting with the construction there should first be a clear understanding of which parts of the supply are to be built first and the actual construction procedure.

Therefore, a work programme should be developed which includes the phases and sequences of the construction. Such a work programme is normally

designed by the supervisor and technician in charge of the site, and subsequently discussed and agreed upon with the villagers concerned. This is very important since villagers will need to know when they will have to provide labour, local materials etc.

The advantages of a work programme are:

- to know the amount of time needed for construction
- to know the required material needed, as well as at what time it has to be at the site
- to give an idea of the village labour required
- to optimize the work procedures
- to plan for the following project

3.2 Site Management

3.2.0 General

On every construction site must be one person in charge of the work. This person needs to have the technical know how and professional ability, as well as a disciplined personal behaviour (authority) towards his workers, supervisors and villagers. He is authorized and supervised by a supervisor or engineer.

Project name:

Village Water Supply

Name of engineer:

Form:

Name of supervisor:

Date:

Months →		1	2	3	4	5	6	7	8	9	10
Structure	Section										
Spring catchment	Excavation	■									
	Building		■								
Siltbox	Excavation		■								
	Building			■							
Pipeline SB - Tank	Excavation		■								
	Mounting			■							
	Backfilling				■						
Tank 3 qm	Building			■							
Pipeline	Excavation			■							
Tank - Tap 1 - 6	Mounting			■							
	Backfilling				■						
Standpipes	Building			■							
Springcatchment	Excavation			■							
	Building				■						
Tank 5 qm	Building				■						
Pipeline	Excavation				■						
Tank - Tap 7 - 9	Mounting					■					
	Building						■				
Standpipes	Building						■				
Work completed within total 6 months											
Staff requirement	Foreman										
	Mason 1										
	Mason 1										

3.2.1 Preparation before construction

Before the construction of a project starts the following things need to be organized, implemented and checked:

- a. The involved villagers have to be informed about the ongoing activities, as well as the proposed work programme.
- b. The location of the structures and the alignment of the pipeline is marked in the field.
- c. The official agreement with the villagers for the contribution of labour (stone shaping, trench digging, etc.) as well as for the preparation work must now be settled.
- d. The confirmation that the locally prepared material fulfills the required quality standards.
- e. If necessary, the accommodations for the skilled labour are prepared.
- f. The required building material for the first phase (that is not available in the village) is transported to the site.

Remark:

Projects should only be started after the preparation work is finished. Otherwise the construction time

will be increased as well as creating the unfortunate situation of labourers just standing around. It is very important to motivate the people to do good quality work, to insure a well built and long lasting water supply system.

3.2.2 Implementation

When the construction of the project has started the person in charge has to organize and coordinate daily the ongoing work. This is, as mentioned before, a very important part of the construction. The following points have to be checked daily:

- a. Organize and supervise the work on the site
- b. Explain the job to the workers as well as to the villagers, and make clear the daily target which is expected from them.
- c. Check the work, and if necessary correct it, or adapt it to the situation.
- d. Plan the work for the next day, and inform the workers and villagers.
- e. Organize in time the ordering and delivery of the required building materials.
- f. Keep the administration like daily reports, store book, orders for materials and transport up to date, as well as the controlling of material at the site.



3.2.3 Reporting

The reporting is an essential component of the project and will help to avoid mistakes, as well as to keep a high standard of work at the construction site.

Reports are made for ordering and controlling of materials as well as controlling the progress at the construction site and the engagement of the construction crew.

The implementation of reporting depends of the size of the project and the format must be carefully considered to produce useful application.

To make the administrative and reporting part of a water supply as simple and efficient as possible there are different examples of forms given in the appendix to report and describe:

- Materials requirements for pipes, fittings, building materials
- Standard tools and equipment
- Additional tools
- Construction site report
- Personal report
- Construction labour evaluation

Computer based reporting

HELVETAS Nepal has developed a useful computerised reporting programme for processing and analysing of technical data, stock control data and statistical data of drinking water projects.

This computer based reporting programme can be purchased. Please contact HELVETAS, Switzerland or HELVETAS, Nepal.

3.3 Setting out

3.3.0 General

Setting out is bringing the indications from a plan to the real situation. In this manual simple methods used for setting out are described. A basic knowledge of measuring distances is required.

(This series of manuals always uses the metric system.)

Materials used for setting out:

- staff
- straight edge
- meter
- meter ruler

- plump bob line
- spirit level
- tape

3.3.1 Measuring of distances

Short distances are measured with a staff, meter or ruler, longer distances with a tape. All the distances have to be measured horizontally, therefore, if working on a slope, a straight edge or staff have to be used. The tape should always be stretched, a sagging tape gives incorrect measurements of the length.

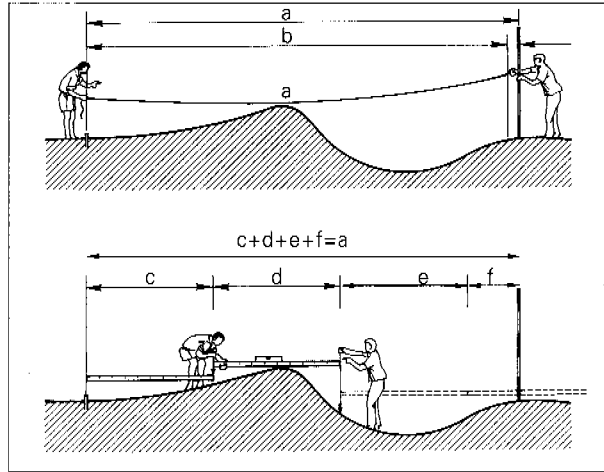

3.3.2 Setting out of angles

The setting out of a right angle is very important for all construction work at water supply projects. The right triangle method is very simple and handy for this purpose.

Example:

Measure the distance from point A to point B of 3 metres along a given line x. Locate point C at a distance of 4m from point A, and 5m from point B. The

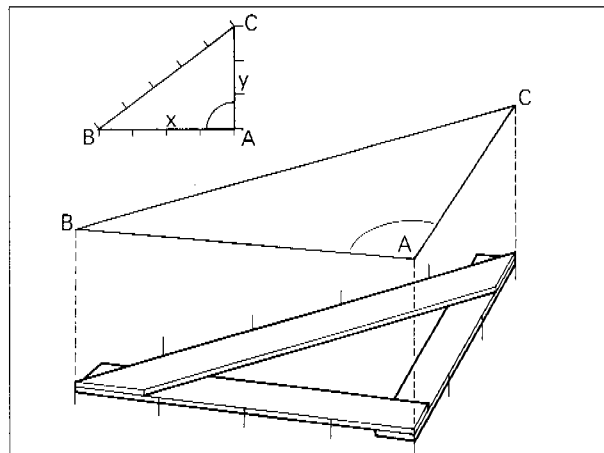

right angle is found at point A formed by the lines x and y.

Other combinations of distances are:

	Point A - B	Point A - C	Point B - C
I	6	4.5	7.5
II	8	6	10
III	12	9	15

3.3.3 Setting out of levels

The levels on a construction site are related to fix points, where the level is known. Therefore, a temporary bench mark should be set next to each structure. This bench mark has to be surveyed by the engineer or technician in charge. The specified level of the structure can be found by using a straight edge and spirit level.

3.3.4 Setting out of buildings

Permanent buildings require an exact setting out. According to the measurement on the site plan the building is set out with batter boards. The following steps should be taken for the construction of batter boards, as shown in the figure below:

1. Install batter boards at all corners, approx. 1.5 m away from the proposed outside wall of the building. Use poles (A) of approx. 12 cm diameter, and planks (B) of about 4 cm thickness.
2. Make sure that all batter boards are approx. at a same level using the water hose levelling method.
3. Mark the outer wall using strong thread line (C) and tape measurement. Tighten the layout, thread by stones. (D)
4. Check that the layout thread lines are in right angle. (E) Use the 3 : 4 : 5 string or wooden square.
5. Check the diagonal, (to be of equal length) for perfect layout.
6. Mark the building lines on slopping terrain with the help of the plump line. (F)

Remark:

The procedure described above is one possible method for setting out for tank construction. For small structures it is not necessary to use stakes and boards. The required accuracy can be achieved with spirit level and plump. When the setting out is made it is important to build a durable strong batter board construction which can stand and remain stable throughout the construction time.

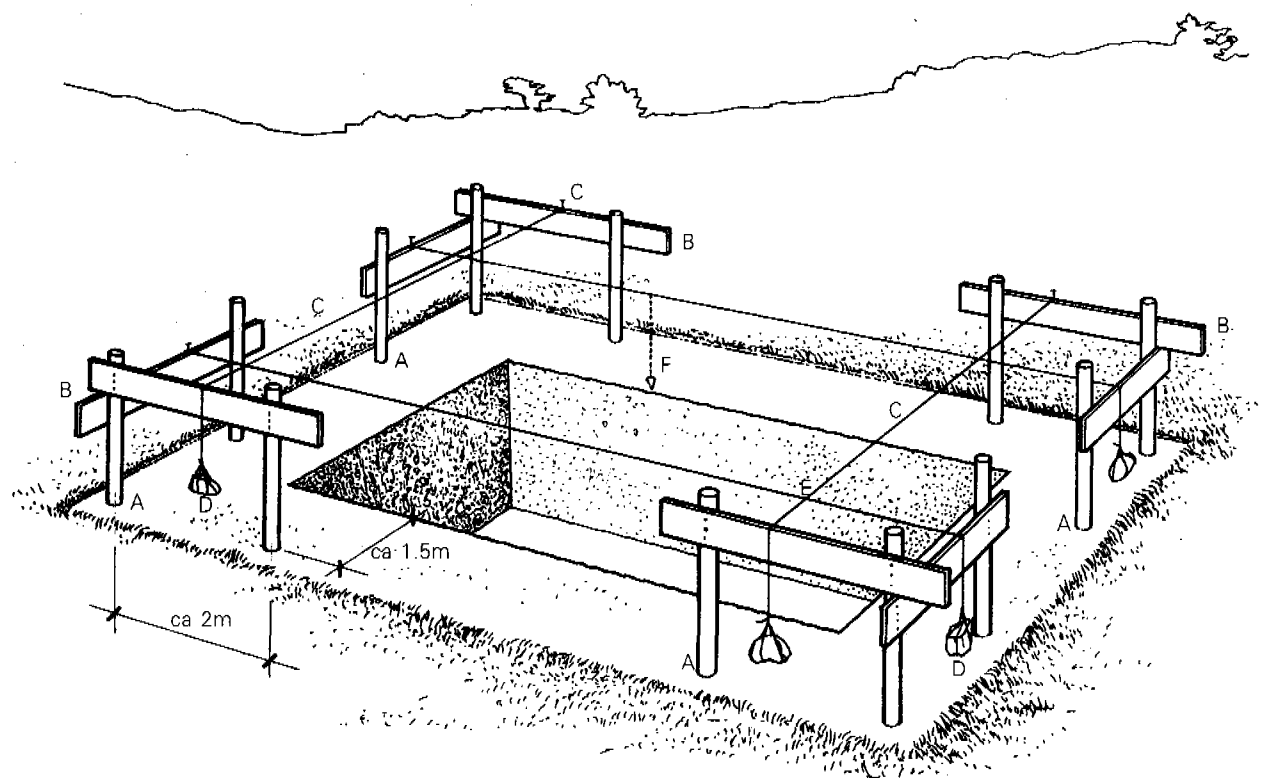

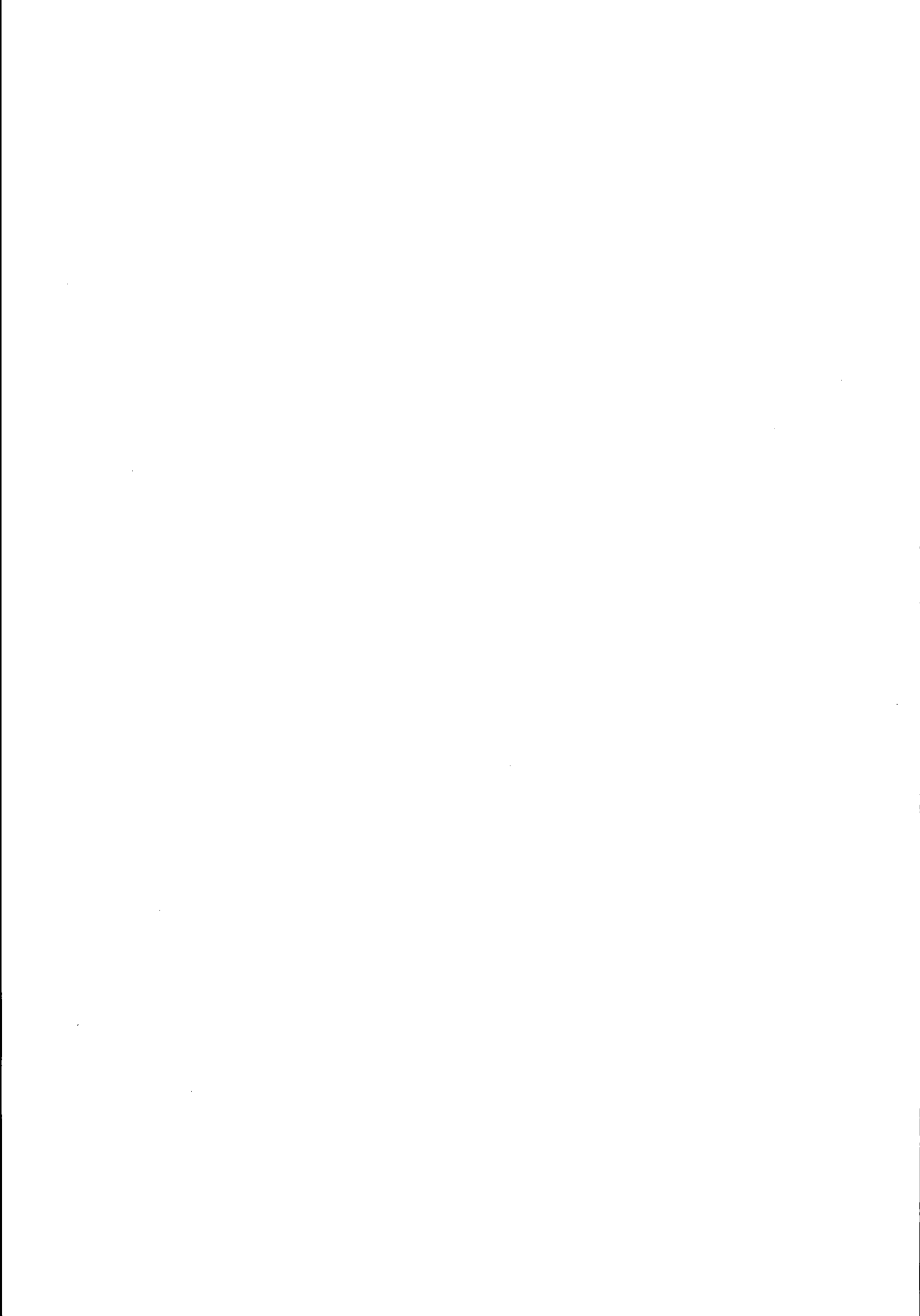

4. Excavation and Backfilling

4.0 General

Choosing sites for proposed structures and trenches requires careful consideration in regard to the technical requirements (altitude, soil bearing capacity) as well as the entire environmental and possible weather influence. Therefore the choosing of the location is of greatest importance, before any earth work is undertaken. Another important point is to avoid as much as possible damage to the surrounding nature, like the unnecessary cutting of trees and subsequent creation of erosion problems due to large disturbance of the overgrowth. If possible no excavation should be foreseen in rocky areas, because it is extremely difficult and labour intensive. Therefore laying of pipelines should be avoided in rocky areas. Other-wise the pipeline has to be covered differently as described later in this chapter. Special attention is also necessary to guarantee the security of labourers working on deep excavations for wells and deep trenches in rocky areas.

4.1 For trenches

4.1.0 General

Trenches not deeper than 1.2 metres can be excavated normally with vertical walls, as collapsing of the walls at this depth should not be dangerous for the working person inside the excavation. Trenches or excavations of more than 1.2 metres depth require a careful consideration of the soil stability on which the necessary "safe slope" depends. Special attention is required near houses, rivers or roads to prevent sliding of large areas.

4.1.1 Permissible slope

In general the permissible slopes are as follows:

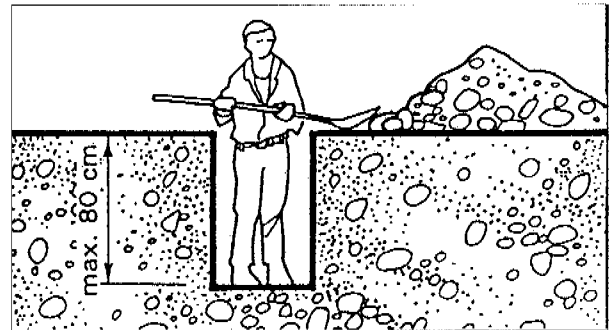

With solid ground

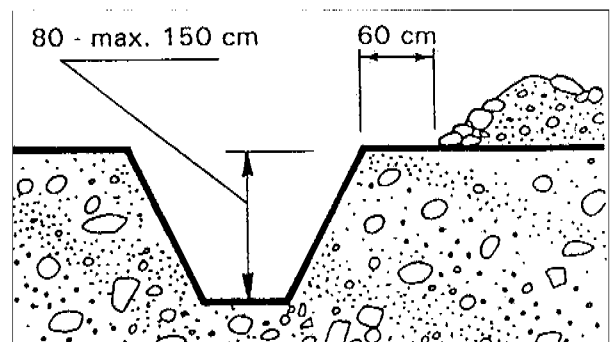

solid ground

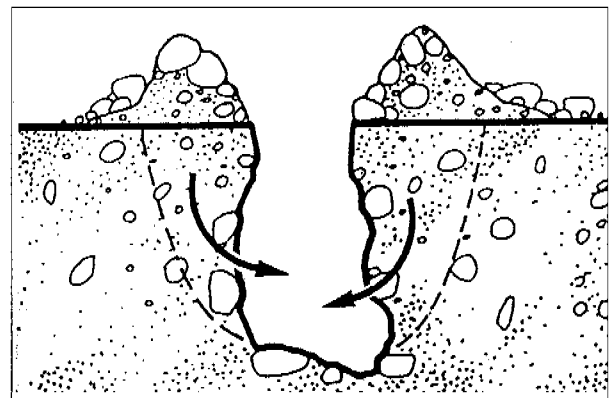

loose ground wrong excavation

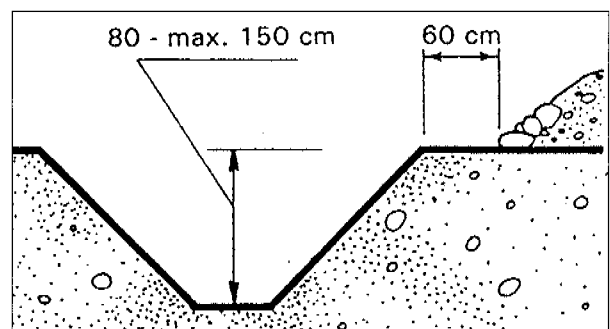

loose ground correct excavation

4.1.2 Boundary rods

With the use of boundary rods on the construction site the slope of the trench can be easily marked and continuously checked during construction. If the slope of the trench because of certain circumstances is very little (less than 3%) the use of boundary rod is most important to guarantee a proper pipe laying.

4.1.3 Depth of the trenches

The depth of the trenches required for water supplies depends on different aspects. The main idea

of covering the pipes is to protect them from damage through stepping on them, cuttings by ploughing or burning by bushfires. The achievement is a longer lasting supply system. Burying the pipe also prevents the problem of freezing, that would damage the pipes, because of the expansion of the ice breaking the pipe. These aspects show clearly that in setting the depth of trenches only a general rule can be made. For each project the depth of the trench has to be considered individually according to the local circumstances.

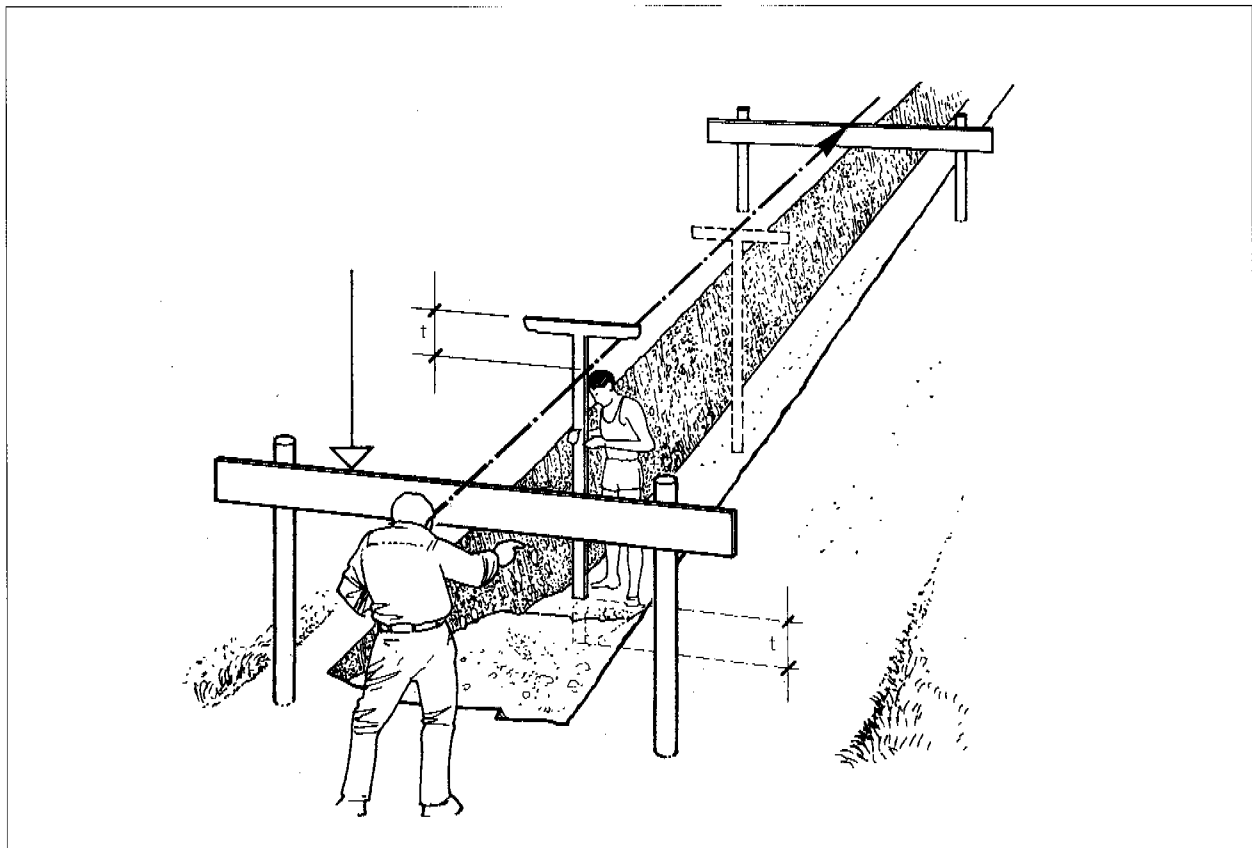
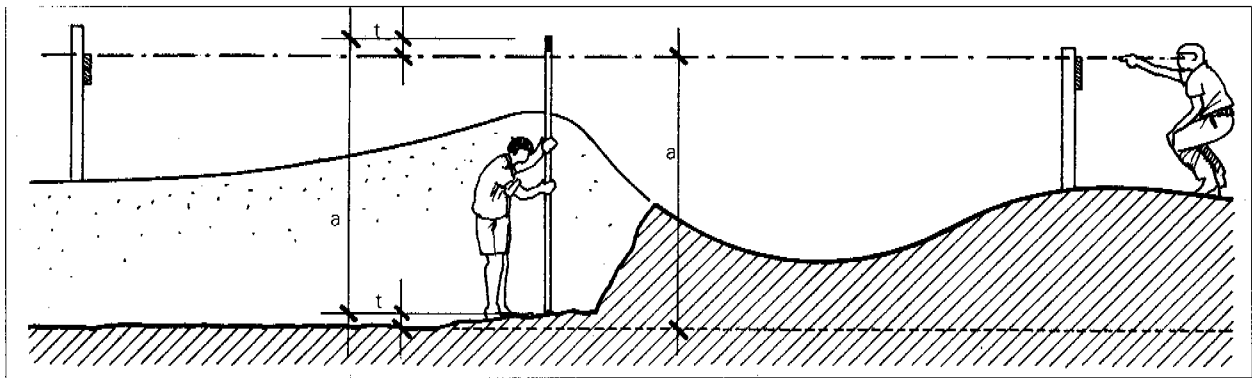

Recommended depth of trenches

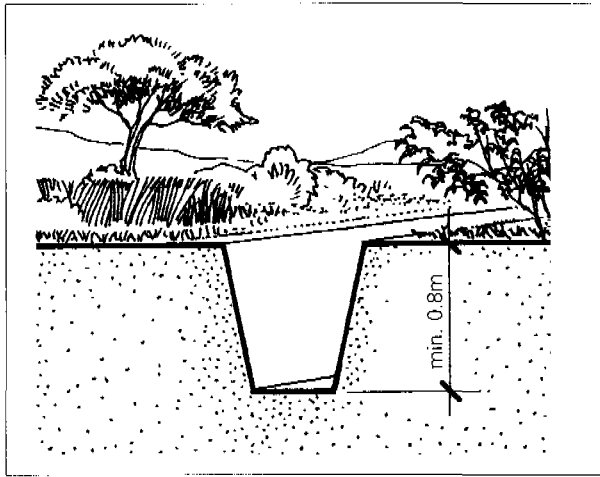

field/bush min. 0.8 m

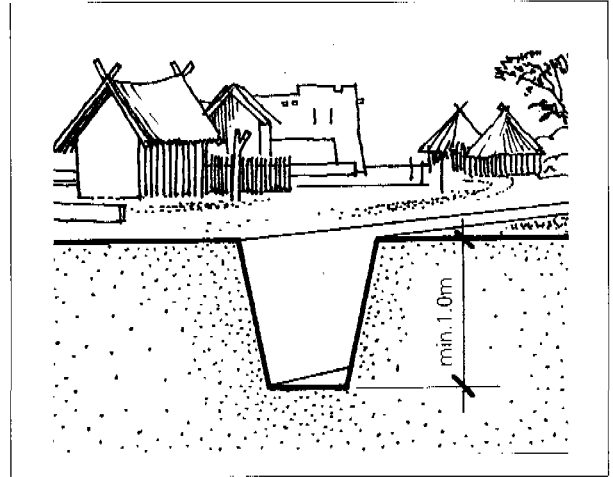

village min. 1.0 m

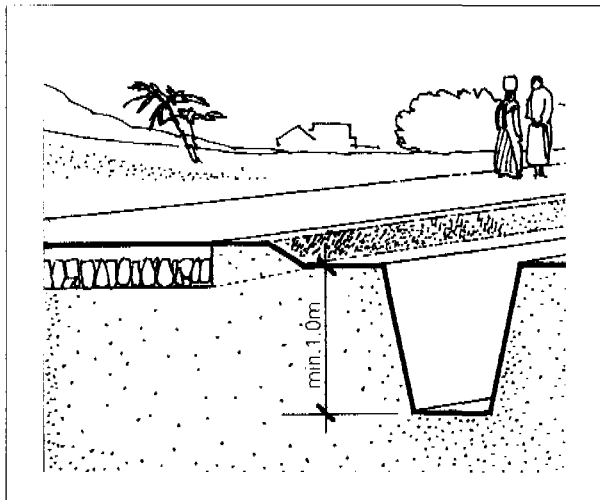

along roads min. 1.0 m

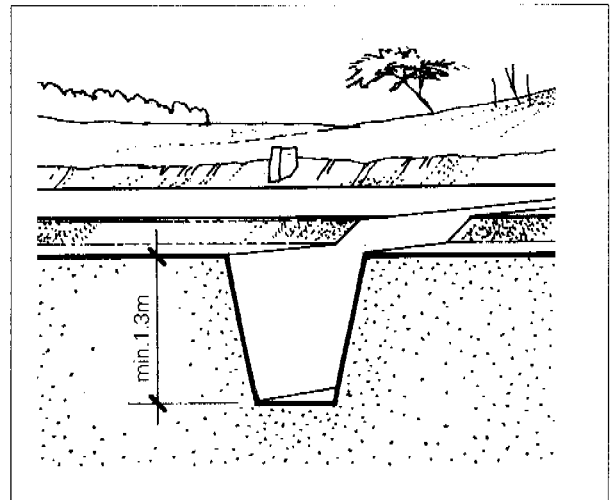

road crossings min. 1.3 m

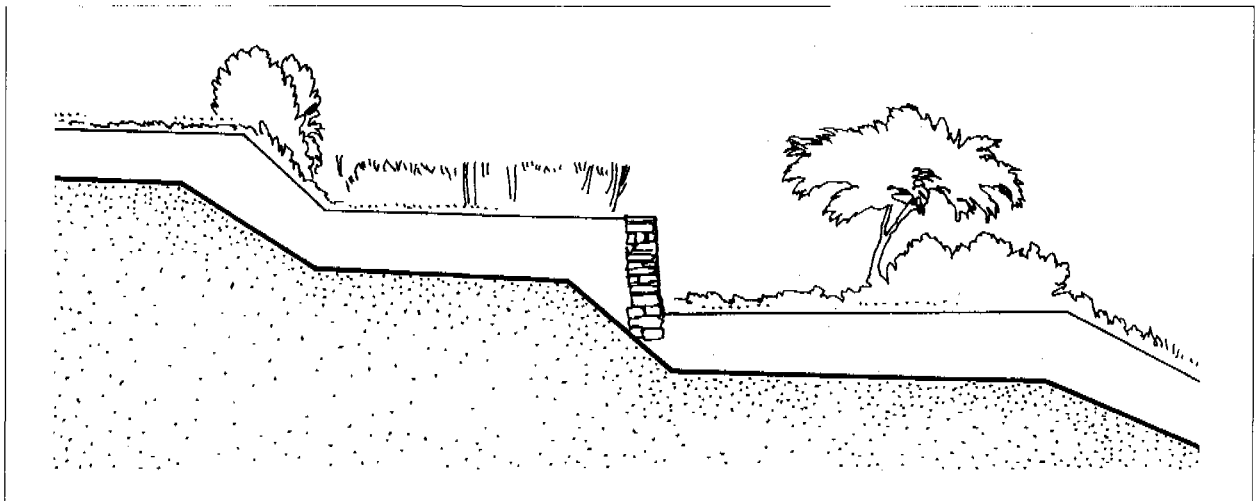

terraces min. 0.8 m

4.1.4 Width of the trench

The width of the trench is determined together with the depth to allow a proper working space. The width depends as well on the size of the pipe. It is important that the required work for piping can be carried out easily inside the trench.

4.1.5 Trench strutting

Alignment of pipe trenches should be carried out in a way to avoid unnecessary deep excavations. If there is no other solution other than a deep trench there is still the possibility to excavate with a safe slope of 1:1 (relation of height to depth). If this solution cannot be considered the strutting of the trench is the only possibility. The construction of the strutting has to be done carefully and requires an experienced builder.

Horizontal Trench Strutting

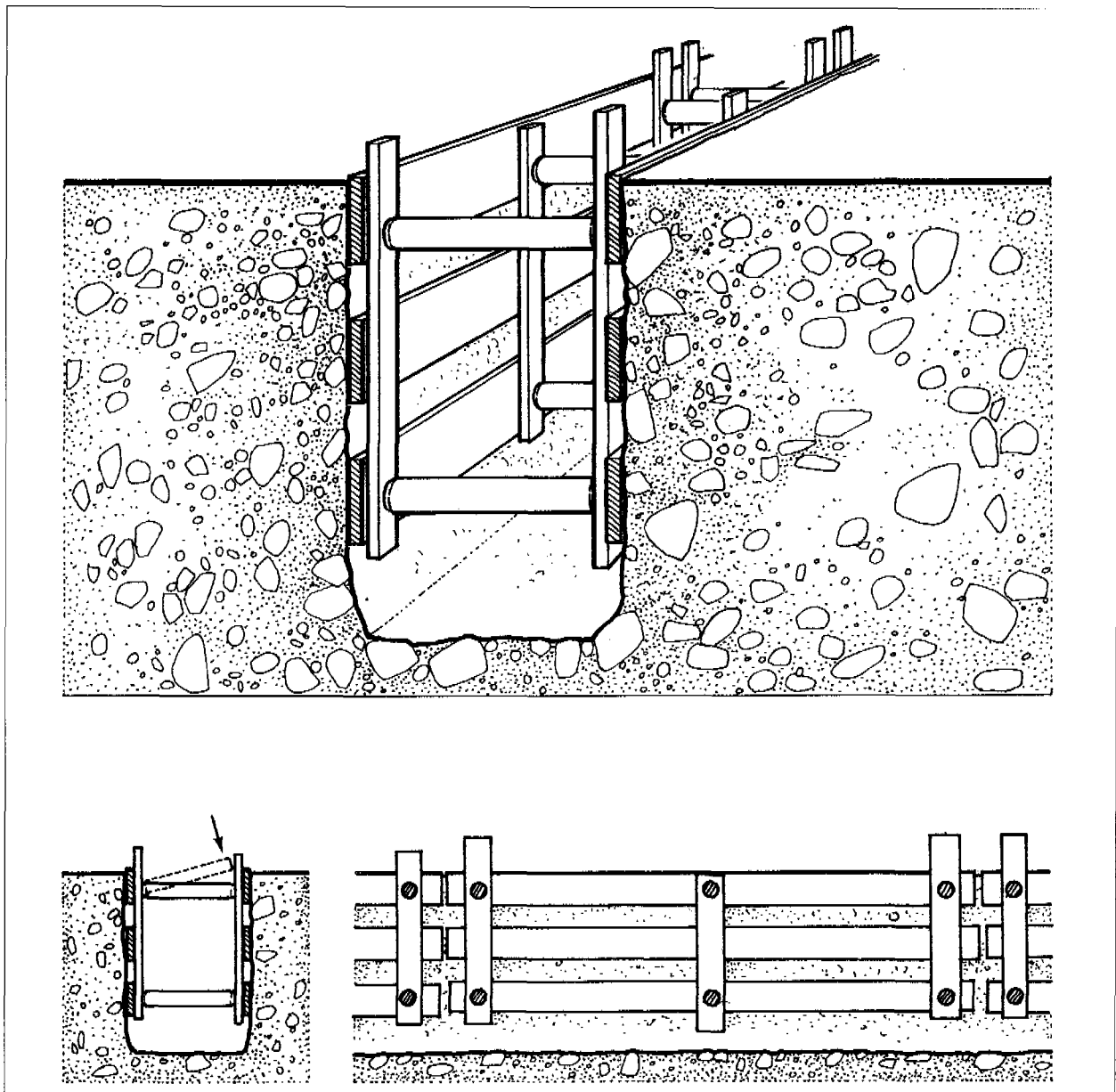

Vertical Trench Strutting

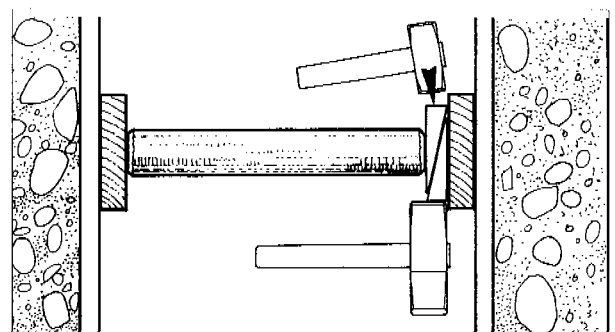
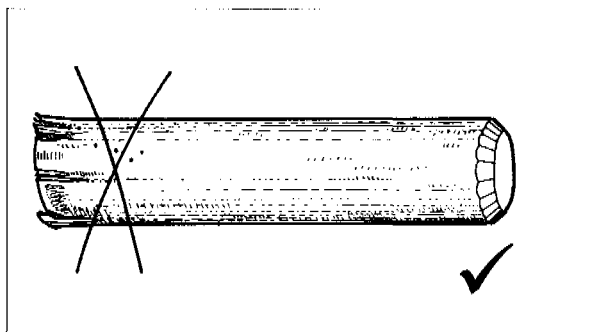
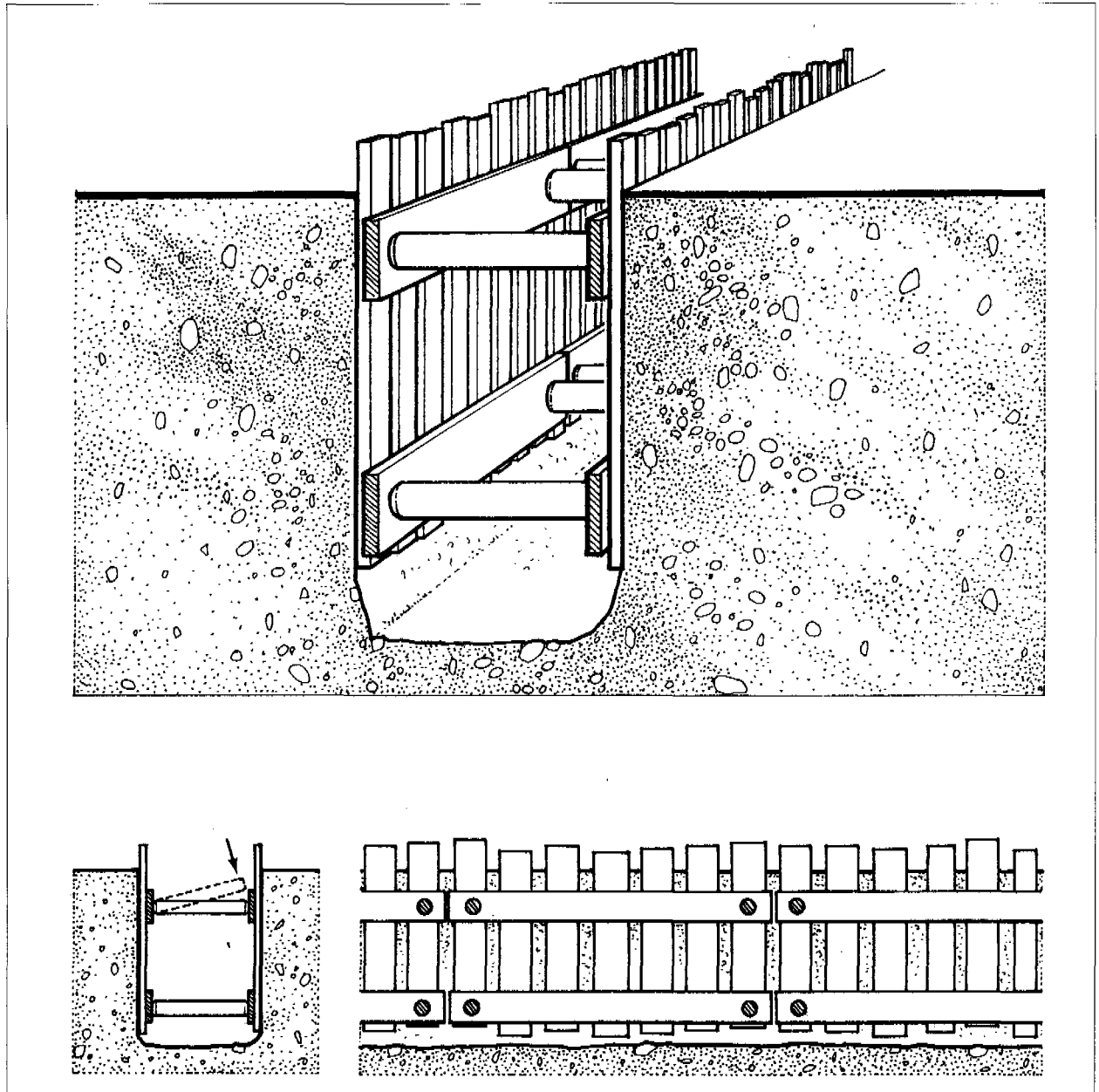

4.1.6 Backfilling

Backfilling of any excavation needs proper compacting in layers of maximum 30cm of height, otherwise damage can occur to the structure of the pipeline, and occasionally can cause a sunken area at the top of the trench causing accidents. A backfilling that is even well compacted experiences over long periods a certain settling. Therefore, the backfilling should always be a little bit higher than the surrounding area. The aim of compacting is to reduce such settling to a minimum and to avoid erosion problems. The excavated material is normally used again for the backfilling. Never put stones directly on top of the pipe because this will definitely cause damage to the pipe. To avoid damage to pipes it is

important to backfill fine material or sand directly around the pipe. Special care in backfilling is required in the case of PVC-pipes.

A special backfilling procedure is required for trenches on steep slopes. To avoid erosion it is very important to build dry wall at least every 5 metres and on very steep slopes at even shorter distances, determined by the angle α , as given in the sketch below.

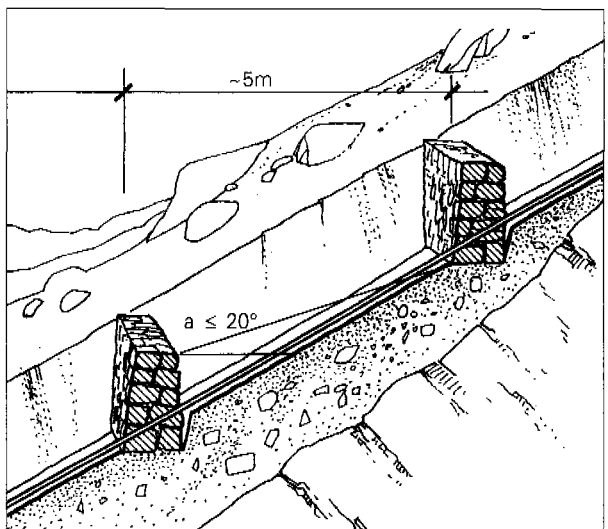
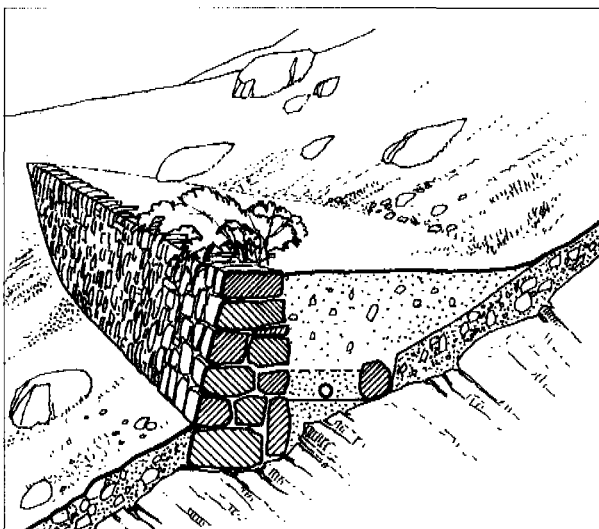
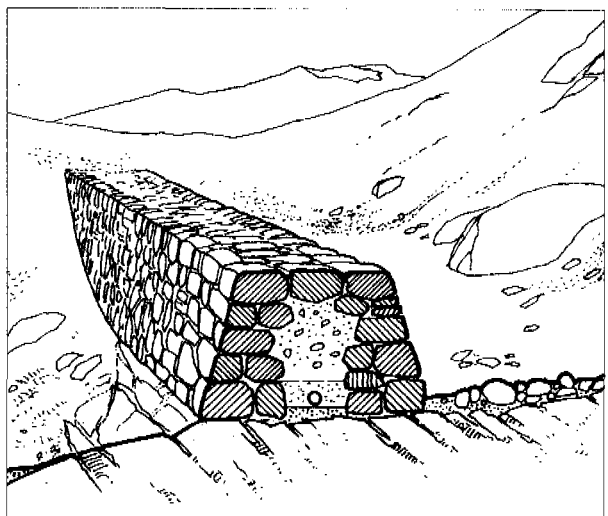
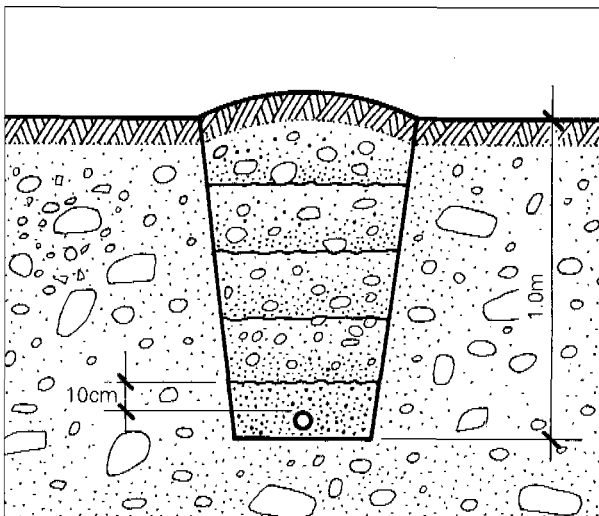

4.2 At tank sites

4.2.0 General

The excavation and backfilling work at the tank side follows the same procedure and rules as mentioned above. At the tank site the excavation always has to be done in such a way that workers still have enough space to work around the structure (to build the wall).

The excavation at the tank site always needs safe slopes of 1:1. Strutting at tank excavations is not possible because the excavation area is in general large and in the middle of the excavation the work has to be carried out. The water tap for the construction of the tank should be positioned so that no water (waste) can enter the excavation area, as wet soil can not be used for a foundation bed (see chapter 5.1.1 Bearing capacity). This can also occur

when rainwater softens the foundation bed, therefore it is recommended to excavate the last 10cm just before the foundation is cast. For the safety of workers, villagers, and animals, a deep tank excavation should be fenced during construction.

The backfilling has to be done in layers of about 30 cm that are properly compacted. The area of backfilling around the tank side should be planted with grass to keep the area clean, as well as to prevent erosion.



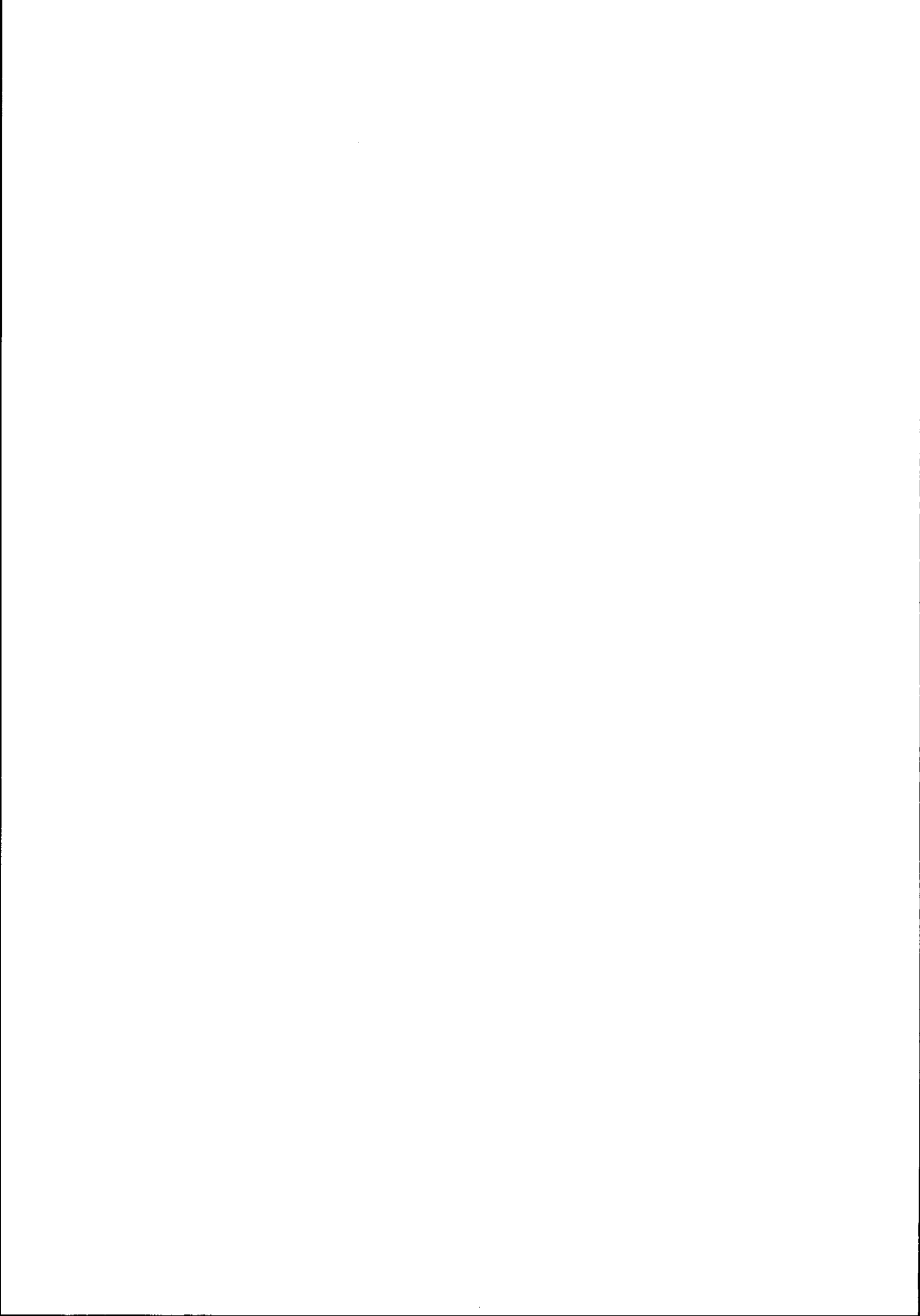

5. Foundation

5.0 General

Foundation is the name for the structural part on which structures like tanks, catchments, chambers and walls rest. It is the lowest part of a building and in general below the ground level. The ground on which the foundation rests is called the foundation bed.

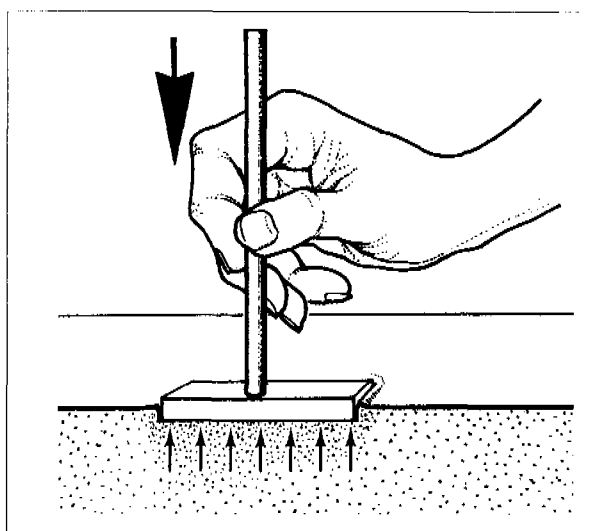
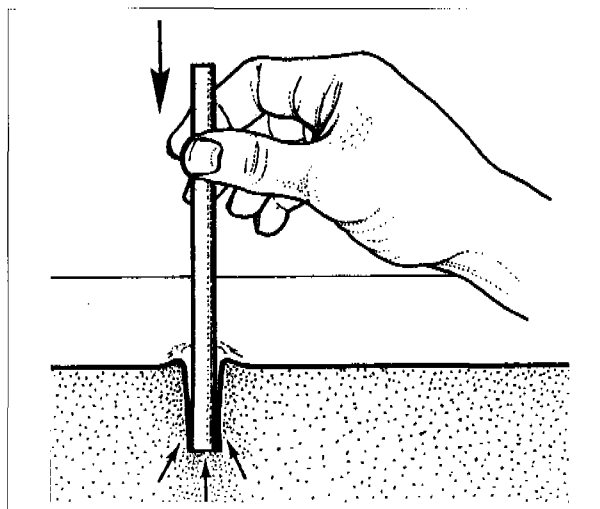

According to the weight of the structure and the type of the soil the size of the foundation needs to be designed. At too small foundation cannot be used in a low capacity bearing soil, it will sink into the soil.

5.1 Types of foundations at water supply structures

5.1.0 General

Structures like walls, single pillars and tanks require different types of foundations. Where ever foundations are built the foundation bed should be of uniform material. The strip and plate foundations are common for water supply structures.

5.1.1 Bearing capacity

The foundation bed or the ground upon which the structure stands has a defined bearing capacity which depends on the nature of the ground. Hard and crack free rock as building ground is most suitable, and there is no costly foundation necessary other than some levelling for the respective masonry afterwards.

If the ground is humid or wet the bearing capacity is strongly reduced. Therefore, foundations on wet underground do not fulfill the requirements for water supply structures. If just the topsoil is wet it has to be removed before starting with the construction of the foundation.

The best foundation bed is rock, and the worst are wet clay and/or silt. The following are the most common foundation beds, and their bearing capacities are described below:

Rock: (3-10 kg/cm²)

When rock forms the foundation bed it is usually sufficient to cut the rock into a level bed and wash it before the foundation is cast. Instead of cutting the rock to a level bed it can be levelled also by using lean concrete or gravel.

Gravel: (dry and humid 2-5 kg/cm²)

Gravel is the next best foundation bed. It has a high compressive strength and is unaffected by atmos-

spheric influences like rain or frost because the water is drained properly through the gravel.

Sand: (0-1kg/cm²)

is usually not recommended as a foundation bed. It requires a complicated and expensive foundation that should be avoided.

Sand, silt and clay: (0.5-5kg/cm²)

The combination of these materials can provide a reasonable foundation bed, but it is most important to keep the water out of this material. The presence of water strongly reduces the bearing capacity. Foundations on this material have to be carefully planned and constructed.

5.1.2 Size of foundation

The size of the foundation is designed according to the bearing capacity of the foundation bed. The load to be applied is a combination of the "dead load" which is the weight of the structure itself, and the "live load" which is for example the weight of the water in a storage tank. This combined load is the weight which the foundation transfers into the foundation bed, and therefore has to be supported by the foundation bed. Possible designs of foundations are described in the manual *Engineering* of this series.

5.1.3 Strip foundation

Strip foundations are the easiest and most often used foundations for simple constructions

The width of a strip foundation depends on the bearing capacity of the ground, and the thickness of the wall. The height of the unreinforced strip foundation should be bigger than the thickness of

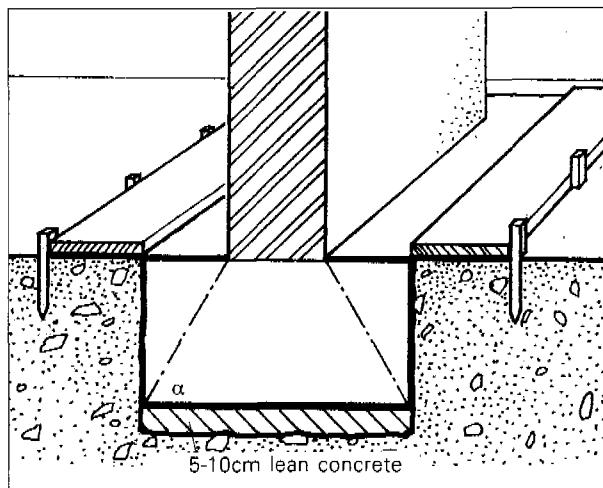

the wall.

Typical measurements for un-reinforced strip foundations on a foundation bed with low bearing capacity (1-2kg/cm²) are:

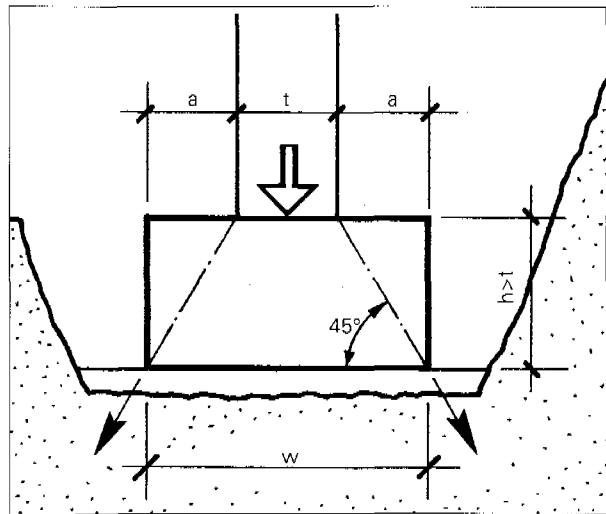

Thickness of wall, t [cm]	distance a [cm]	height h [cm]	width w [cm]
~ 10	10	15	30
~ 25	30	30	85
~ 35	40	40	115

On soils with a higher bearing capacity (~4kg/cm²) the angle α can be increased to: $\alpha \geq 60^\circ$.

5.1.4 Slab foundation

The slab foundation is a slab of reinforced concrete laid over the ground. The size of the foundation is slightly larger than the building, so that the load is spread evenly into the foundation bed as explained before. It is very economical for small structures and the most suitable for water containing chambers like storage tanks, spring chambers etc.

The reinforcement for plate foundations is set in on top and on the bottom of the slab. This reinforcement is required because of the different distribution of the load by the walls and the water.

5.1.5 General rules for foundation construction

- The soil of the foundation bed must be uniform. If not so, it is better to shift the building to a place where the ground is uniform.

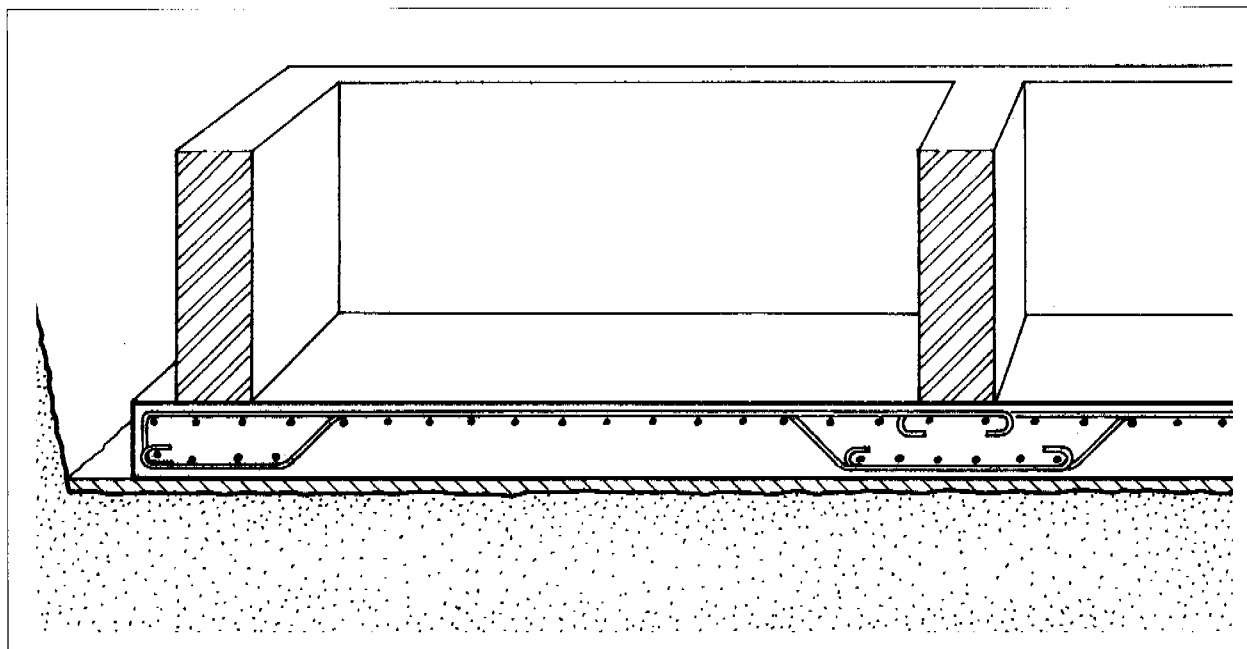

- The foundation bed must always be levelled.
- On steep hills the levelling is achieved by means of steps.
- The depth of the foundation below the ground depends on the nature of the ground. Topsoil like humus always has to be removed.
- Erosion of the foundation has to be carefully considered and precautionary measures have to be foreseen to drain the rainwater around the structure.
- In cold climates the depth of the foundation has to be designed so that freezing of the foundation bed is avoided. Freezing causes an expansion of the soil which creates a strong force which can lift up the structure, causing cracks and therefore disturbing the building.
- All the loose material which may fall into the foundation has to be secured or removed before casting the foundation.
- If the excavation is dug too deeply, don't fill in soil to save concrete, use lean concrete or compacted gravel.
- If the excavation is finished, the foundation should be built as quickly as possible, especially during the rainy season (to prevent swelling of the ground due to rain water).

5.2 Special foundations

5.2.0 General

Sometimes the location of the building is on a place where it is not possible to build strip or plate foundations. Therefore it is sometimes necessary to adapt these types of foundations according to the individual circumstances, as described below.

5.2.1 Foundation on uneven ground

If the ground in the excavation cannot not be levelled, it needs to be levelled through the use of lean concrete. The construction of the foundation can be started only when a level foundation bed is created.

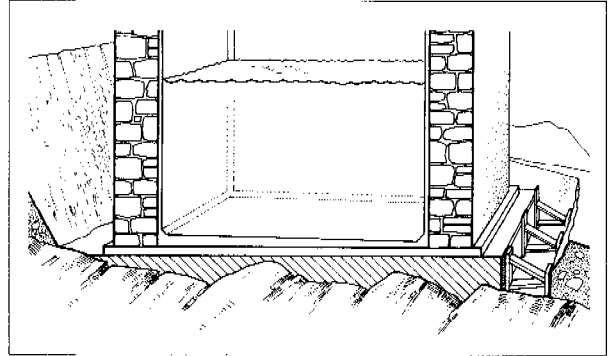

5.2.2 Foundation on steep slopes

If a tank site or other water supply structure needs to be placed on a steep slope, the foundation has to be constructed as shown below:

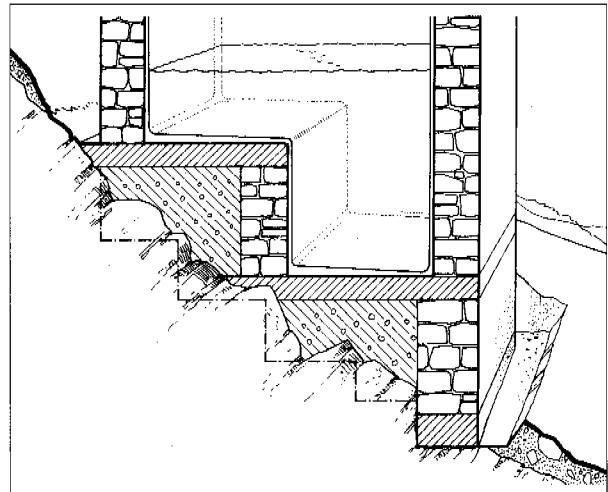
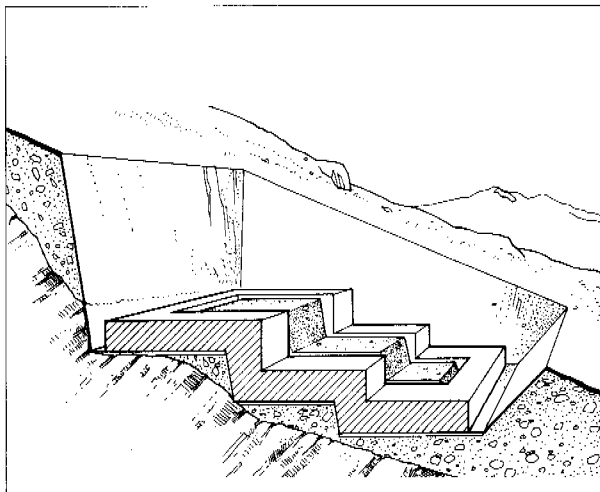
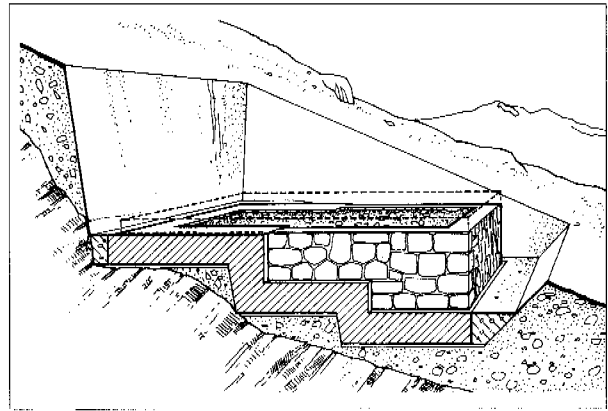

6. Masonry Work

6.0 General

The selection of suitable material for stone and brick construction depends on the required strength of the structure and the availability of usable local materials. The quality and strength of masonry depends also on consistent high quality and accurate workmanship.

6.1 Cement mortar

6.1.0 General

Mortar may be defined as a material composed of fine aggregate and cement which forms a hardened mass after mixing with water. It is used in the beds and site joints of masonry work in order to bind the stones, bricks or blocks together, and thereby distribute the pressure throughout the blockwork.

Good mortar used for masonry consists of cement, sand and water in the correct proportions. The sand has to be clean and needs the correct granulation. Sand without fines (below 0.5mm) gives a harsh mortar with low compressive strength and bad workability. Cement mortar usually gives the best result when the sand comprises of the following:

0	–	0.5	mm (60% 0-0.2 mm)	1	part
0.5	–	2	mm	1	part
2	–	4	mm	1	part

6.1.1 Mortar mixtures

For mortar mixtures it is very important to use clean sand and water as well as a proper granulation as mentioned before. A uniform mixture of sand and cement (mixed 2 to 3 times) before adding water is required. Mortar mixed with water must be used within 1 hour, otherwise the mortar hardens and cannot be used any more without essential loss of quality.

The plasticity of the mixture varies according to the

amount of water added as well as being influenced by the original water content of the raw material.

a. Volumetric method

The mix method for small quantities (hand mixes) is the so-called "volumetric ratio cement : sand" method. It is commonly used at village water supply construction sites.

For example the ratio 1:4 means that 1 part cement and 4 parts sand are used for the mortar.

b. Weight method

Mortar mixtures are also expressed in kg of cement per 1.0 m³ of cement mortar. For example PC 250 means that 250 kg of cement, ~1000 litres of sand and 120 litres of water are used to obtain about 1.0m³ cement mortar.

c. Plasticity

The plasticity determines the workability of the mortar. Dry mortar is difficult to work with, but also slurry mortar can cause problems in handling. Different mortar mixtures with different plasticity characteristics are used in village water supply structures according to the table given in the next chapter.

6.1.2 Recommended mortar and plaster mixtures and their use

The following chart shows the various recommended mixtures and their use for water supply structures. The required mortar mixture should be described in the construction plan of the structure, or defined by the engineer or supervisor in charge.

Used for	ratio cement : sand	biggest grain	consistency	remark
MORTAR				
Building with bricks	1 : 4	4mm	plastic	biggest grain max $\frac{1}{2}$ thickness of the joints
Building with blocks	1 : 4	4mm	plastic/stiff	
Building with stones	1 : 4	4mm	plastic/stiff	
Topping	1 : 3	3mm	stiff	
Pointing	1 : 2	2–3mm	plastic	
WATERPROOF PLASTERING				
Spatterdash	1 : 2	4mm	slurry	Sand should be clean and coarse if possible
Rendering coat	1 : 4	4mm	plastic	
Setting coat	1 : 2	1–2mm	slurry	
Cement paste	1 : 0	–	slurry	

Remark:

Increasing the cement content in mortar does not increase the strength of the wall built. It is also important that the bricks, blocks or stones are of good quality and soaked in water before use. Decreasing cement content will weaken the strength of the mortar, and the structure will not fulfill the requirements. A badly built structure will be maintenance intensive and could even collapse during or just after construction. Remember any construction is only as strong as the weakest element used in the structure.

6.2 Pointing, plastering and topping

6.2.0 General

A great many constructions, even in exposed areas, are never plastered. It is wrong to think that the durability of a building is systematically and only linked to the presence of a plaster. The first function of a plaster finish is to improve the appearance of a building. If using a plaster is to be avoided, the building must therefore be carefully constructed and where necessary pointing work made. External plaster finishes have an additional function which is to protect the body of the wall from weathering as well as to protect surfaces from the effect of flowing water or of regular submersion in water such as inner walls of water storage tanks.

Pointing, plastering and topping are important works for the correct finishing of many construction details for a water supply system. The quality of this work determines the final durability of the building, and has a direct influence on the future maintenance work for the system.

6.2.1 Pointing

The reasons for pointing the surface of blockwork are to increase its weather resistance and to give a neat looking finish to the work.



Pointing can be carried out as the construction of the blockwork proceeds, using ordinary mortar in which the blocks are bedded. This type of pointing is called struck jointing and is much cheaper than the pointing methods described below. Another method is to finish the masonry work first and then to make the pointing work with a 1:2 cement mor-

tar later. The joints must be raked out to a depth of about 1 to 1.5 cm, brushed, washed and filled with a 1 part cement and 2 part sand mortar.

For masonry in general the following mortar pointing finishing is suitable. It will help to avoid that rain-water penetrates into the structure through the horizontal or vertical mortar bed layers. Because the mortar bed layers are the weakest part of the wall, they must be protected properly.

a. Flush-pointing

For not-exposed buildings. It can be used below ground level and as well if the wall will be plastered.

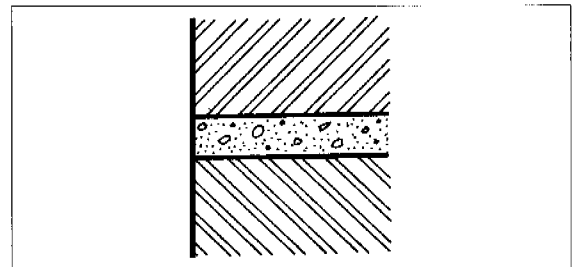

b. Curved-pointing

Used for exposed unplastered walls built in burned bricks or cement-blocks. Especially for exposed stone masonry walls.

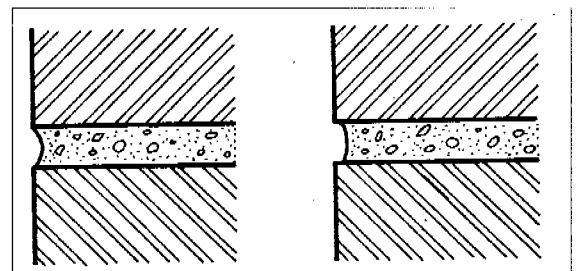

Made with pointing tool or a piece of small pipe. Two centimeters of the set mortar is scratched out of the joints and later filled with pointing mortar of a ratio 1:3 to 1:2 as shown in the drawing. This pointing is work intensive and expensive, but has a big influence on the quality of the structure.

6.2.2 Plastering

Plastering is the process of covering walls with a substance which is applied while still plastic and which hardens later. Plastering may be carried out in one, two, three or more coats, depending upon the quality requirement.

Plaster consists of the same materials as mortar, but sometimes mixed with lime to make better workability. For ordinary internal plastering it is advisable to use fine sand to obtain after floating a smooth surface on which the application of lime is not necessary. The addition of lime is appropriate for operation chamber or inside wall plastering, but must be avoided for plastering exposed to water or rain because of swelling and shrinking. Plastering in general is applied to protect and strengthen the masonry, to give straightness and cleanliness to the wall surface. At water supply structures the use of plastering is very important for the waterproof structures.

a. Waterproof plastering

Water containing structures are plastered in order to make them completely waterproof, and to achieve a smooth surface which allows proper cleaning. Accurate application of the 4 coat plastering as shown below makes application of additional waterproof coating unnecessary. But when cement aggressive water is present additional chemical applications are recommended to protect the cement plaster from disintegration.

Storage tanks, chambers and other water keeping structures in village water supply construction are plastered to waterproof as well to obtain a smooth surface which can easily be cleaned. After years of experience the following different plastering coats can be recommended for water keeping structures:

b. The Wall

Surface must be rough, clean, free from dust, and wet.

■ **Spatterdash (1 : 2)**

The thickness is 4mm, and this coat ensures a proper connection of the plaster to the wall. It makes the plastering waterproof. It has to be mixed slurry with rough sand, and should be applied with force. If necessary (with not completely covered spots) apply this coat twice, then allow it to set for at least 10 days, to avoid cracks in the following coats.

■ **Rendering coat (1 : 4)**

The thickness is 15–20mm and gives the necessary straightness to the plastering (screeds). Never should be floated if a setting coat is to be applied too.

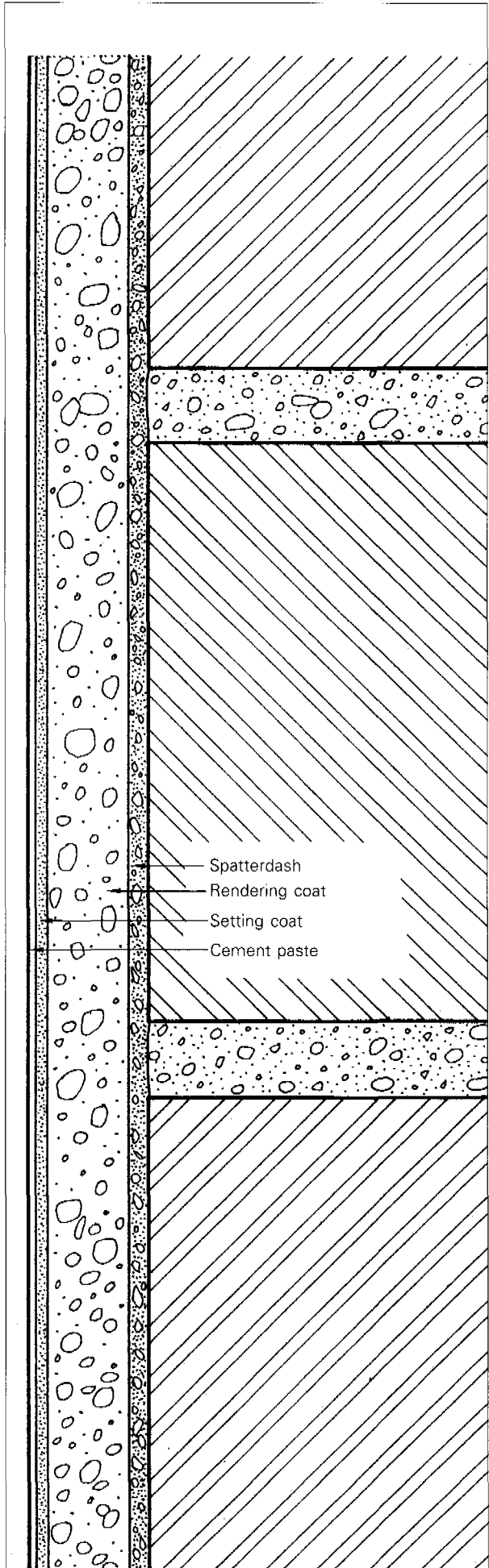

■ **Setting coat (1 : 2)**

The thickness is 2–3mm. This coat smooths the surface. It can be applied immediately after the rendering coat has set. This coat has to be properly floated.

■ **Cement paste (1 : 1)**

This coat is applied immediately after the setting coat is floated. It must be applied slurry and not thicker than 1mm. This coat ensures easy cleaning.

Besides rendering, there are other methods to improve watertightness.

Additives can be added to the concrete mixture (plasticizer, water repellent agents, liquifier, etc). Rendering with special mortar (e.g. Sika products like Sika 101a, Sika Top-Seal 107). Such special mortars have to be approved (accepted) by the respective health authorities or standard organisations before they can be used for water supply structures.

Process of shrinkage must be completed before any watertight mortar is applied. Joint between floor and wall has to be improved with a hollow rounded fillet.

Coatings with epoxy cannot be recommended. Epoxy coatings require a fully dry surface (before application), which can hardly be guaranteed for water supply structures.

6.2.3 Topping

Topping is a cement mortar in a stiff consistency. It is applied mostly as a coat on floors, slabs, walls etc. to protect, give level, and cleanliness to the surface. The best connection to concrete slabs is achieved if stiff topping is floated on concrete which has just started to set. This is the so-called "wet into wet method" and should be used whenever possible. The application of topping on old concrete requires more work steps: chiselling and cleaning of surface, and watering and curing before and after topping. When additional cement paste is required, apply the cement paste immediately after screeding and floating the topping.

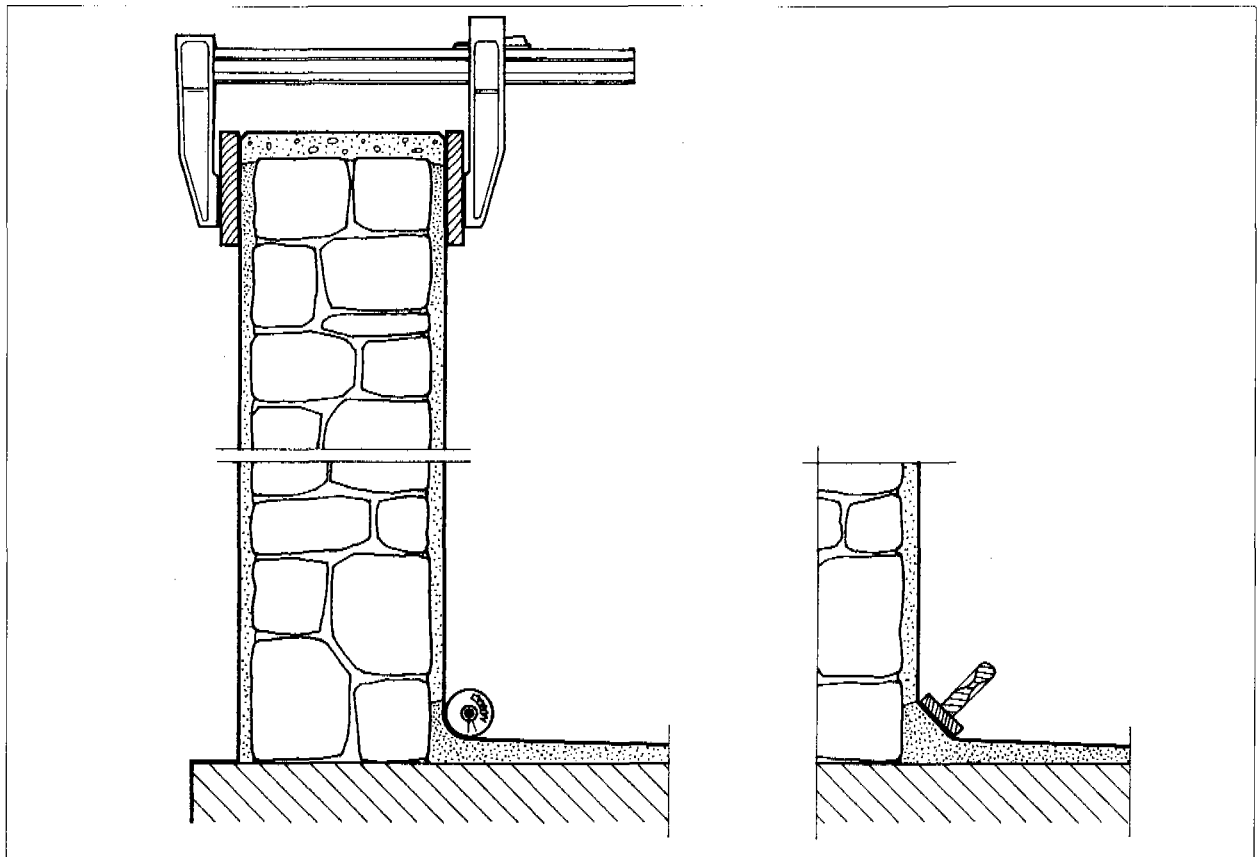

6.3 Brick and block masonry

6.3.0 General

The building procedure for bricks or blocks is the same. Bricks and blocks must be bonded to give maximum strength and adequate distribution of loads over the wall. Only buildings with bonded walls guarantee that the building is safe for the assigned purpose, and will not collapse during the construction.

Unbonded or insufficient bonding produces vertical joints with the accompanying risk of failure as shown below.

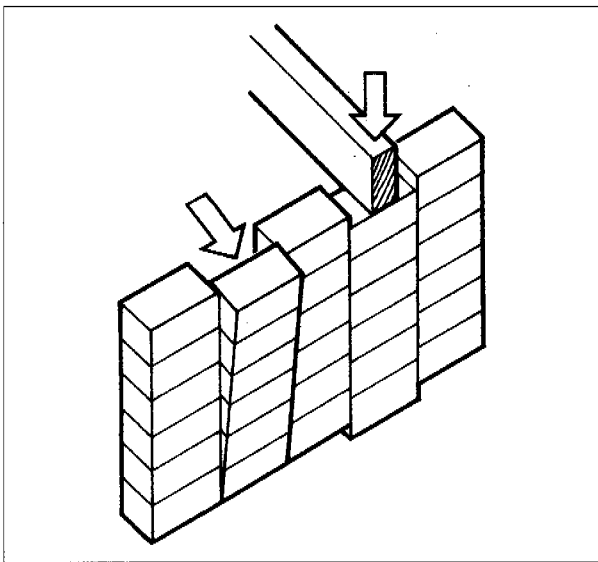

Bonded walls provide stability and resistance to the side thrust, as seen in the figure above. The bond can be selected to give an attractive appearance to the wall face.

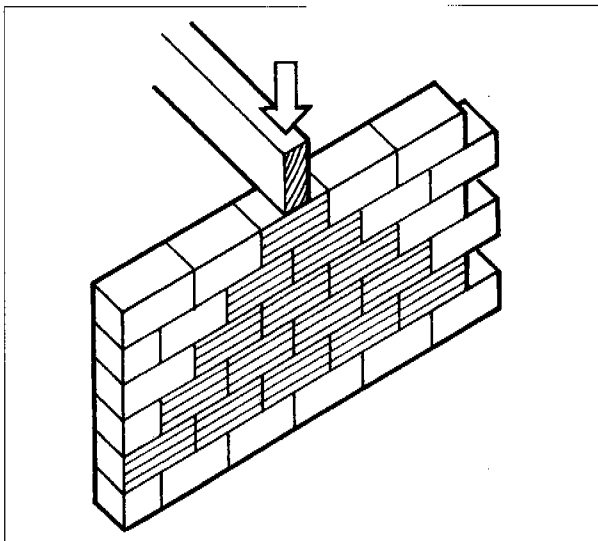

6.3.1 Brick bonding

The term bonding means the arrangements of bricks in which no vertical joint of one course is exactly over the one below. That means the brick is laid in such a way that it overlaps and breaks the joint below. The amount of lap is generally half of the length of a brick. The minimum lap is $\frac{1}{4}$ of the length of a brick.

Bricks with the dimension of 22.5 x 10.5 x 7.5cm are handy to work with and suitable for all kinds of bonding.

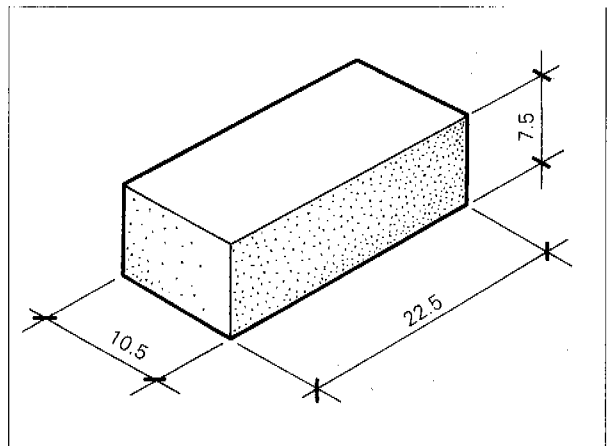

For horizontal joints (mortar bed) the thickness of 12mm is recommended for brick work to ensure:

- levelling of the mortar bed
- placing of bricks completely in mortar
- no uneven or incomplete support of the bricks due to stones in the mortar

If the horizontal joints are too thick (more than 12mm) it is a waste of expensive mortar (cement), as well as a weakening of the structure, because the joints are the weakest part of the masonry structure.

For vertical joints (buttering) a thickness of 10mm is recommended for brick work because of the reasons in the list mentioned above. The reduction of 2mm to the horizontal joints is possible because the contact area is much smaller at the side than at the bottom.

In order to obtain a bond it is necessary to introduce "bats" (parts of bricks). Some of the commonly used brick terms are:

Three quarter brick

Half brick

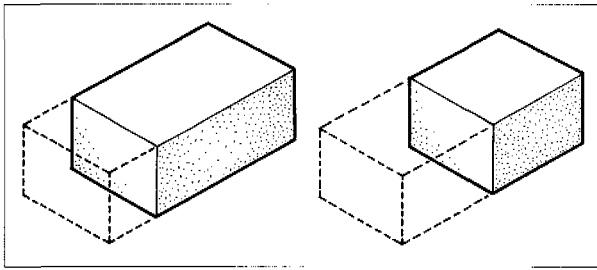

There are many ways a brick can be laid. The most common ways are:

Stretcher

Header

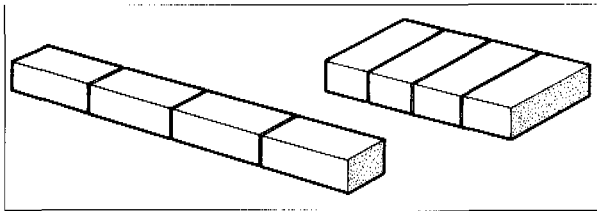

Bricks can be laid in a variety of bondings. To prevent the crushing of bricks use bondings of as many full bricks as possible, three quarter and half bricks. There are other bondings possible, but they are not used for water supply structures.

6.3.2 Cement block bonding

The rules for cement block bonding are the same as the rules for brick masonry. Blocks of different sizes are available.

The most common type and size is:

40cm x 20cm x 20cm

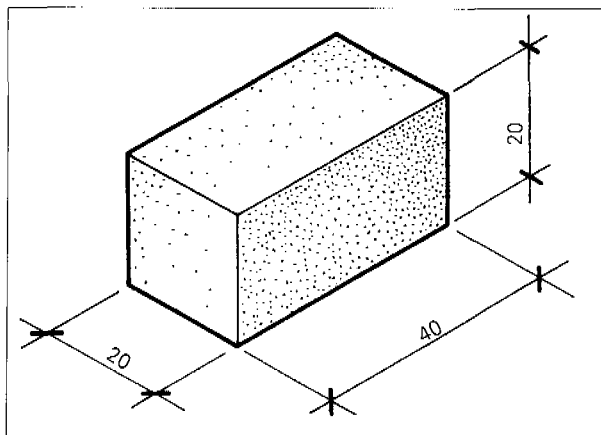

Horizontal and vertical joints are increased to 15mm because of the reasons mentioned above (levelling, placing the blocks completely in mortar, and to avoid uneven or incomplete support). The increased size of cement blocks in comparison to bricks

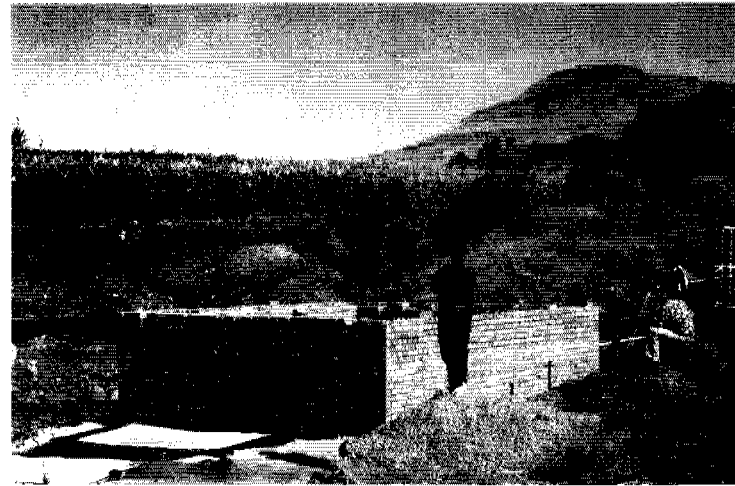

makes cement block masonry very economical. For cement blocks the stretcher bonding is most commonly used.

6.3.3 General rules for bricks and cement block masonry (cement hollow blocks)

The rules required for construction in brick masonry work are:

- a. Lay out exactly the proposed structure by marking the external side of the walls on the foundation (see Chapter 3.3.4).
- b. Clean the foundation with a steel brush, wet it properly, if necessary rough it by chiselling.
- c. Lay the first two courses without mortar to check that the correct bond is achieved.
- d. Cement bricks are cleaned and sprinkled with water, burned bricks are soaked in water for 1 minute before using them. This is important so that the water of the mortar is not soaked away by the bricks or blocks, which would reduce quality and strength. If the brick is not clean, it will reduce the strength of binding with the mortar, as well as producing cracks caused by swelling and shrinking.
- e. Check every brick for its brittleness (sound test) before using it for construction.
- f. Lay the corners exactly with mortar and stretch a line from one corner to the other. There after build the first course in between these marked lines.
- g. In order that all courses have the same height, use a baton (straight edge) marking all courses on it.

Stretcher bond

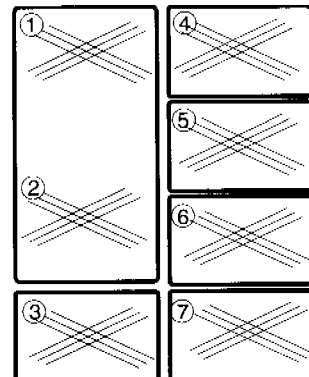
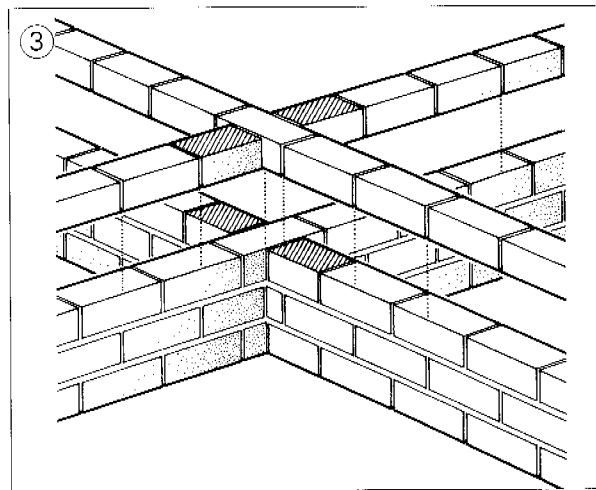
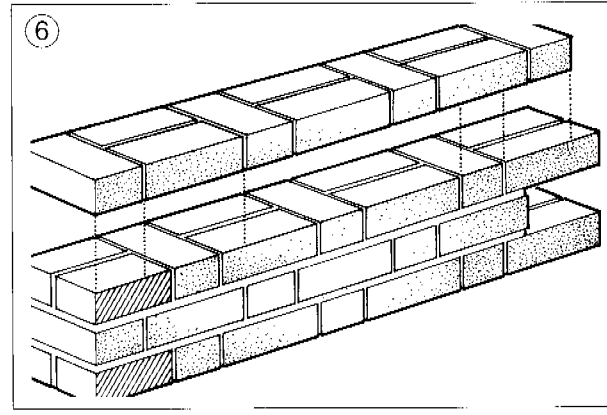
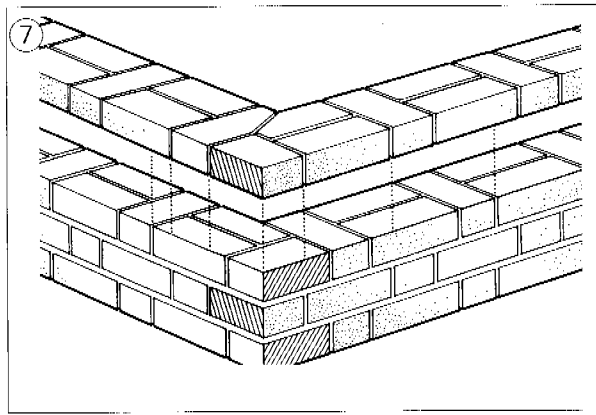
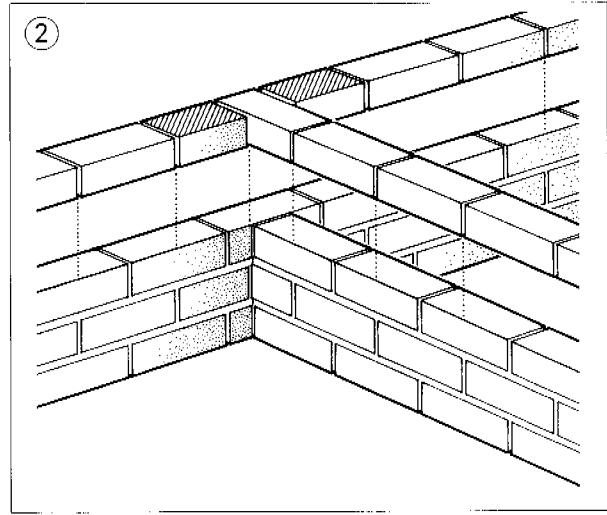
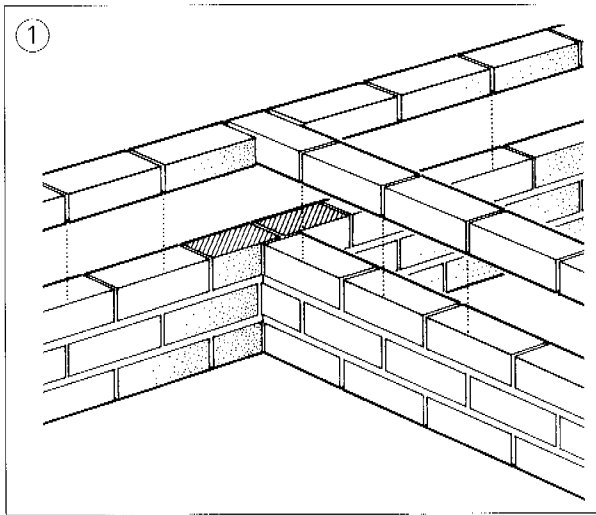
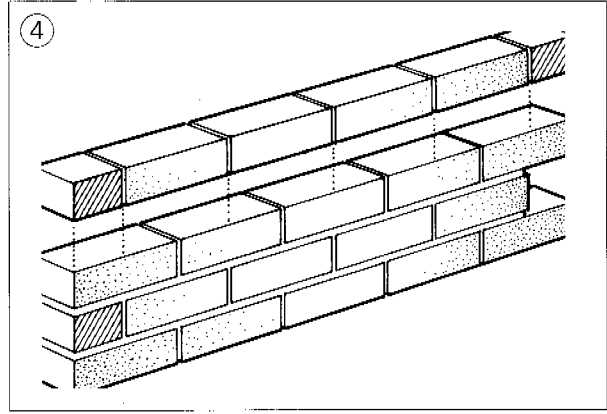
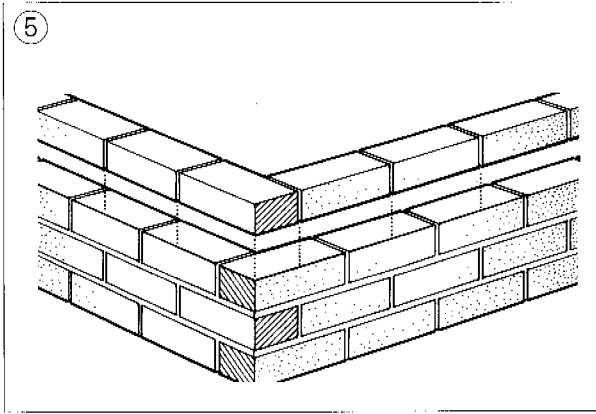

- h. Build the corners 4 to 5 courses high, then work along the line.
- i. Make sure each course is exactly horizontal by using a spirit level.
- j. Build the walls exactly vertical by using a spirit level or a plumb bob line.
- k. Quarter bricks should never be used at the end of a wall.
- l. Use the same bond throughout the job.
- m. Use as many full bricks as possible.
- n. The left over mortar after each layer should be cleaned from the bricks as well as from the ground, so that it can be reused.

6.4 Stone masonry

6.4.0 General

With regard to quality and durability stone masonry is one of the best, but work intensive. For building purposes a good stone should possess strength and durability. The strength of a stone under compression is an important quality factor. Therefore the stones used for water supply structures need to be tested and selected as described in Chapter 2.1.2 and 2.1.3. To obtain a minimum bonding, stones first have to be shaped to their respective sizes. The minimal wall thickness should not be less than 30 cm. Stone masonry requires about 1.5 times more mortar in comparison to brick masonry.

6.4.1 Stone shaping

The surfaces of the stones which need to be cut and shaped are:

■ Face

This is the front surface of the stone in elevation.

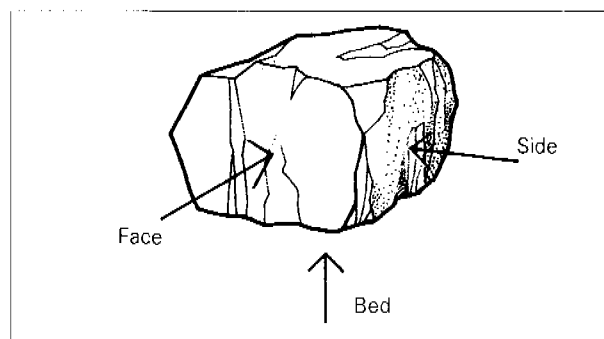

■ Returned face

This is the side surface of the stone.

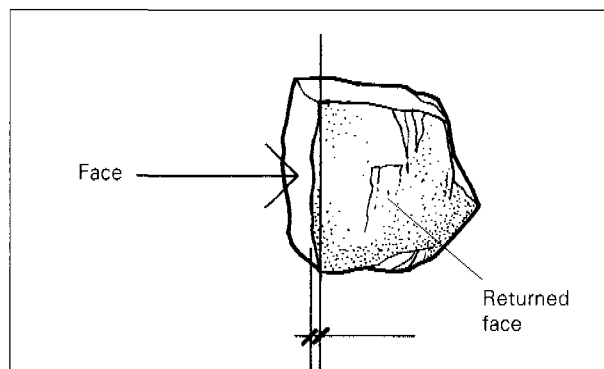

■ Bed

This is the top or the bottom of a stone. The lower surface on which the stone rests and the upper surface which supports the stone above.

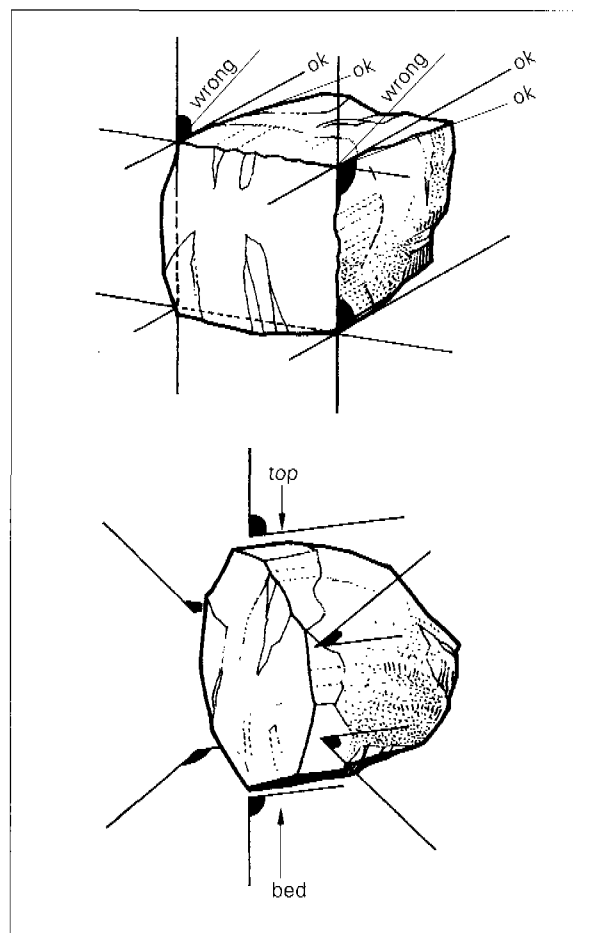

Type of Stones

To shape a stone well is not a problem if enough time is taken to do it properly. Stone shaping can be done by workers who can be trained and supervised locally.

The following shapes of stones are used for construction:

Line stone

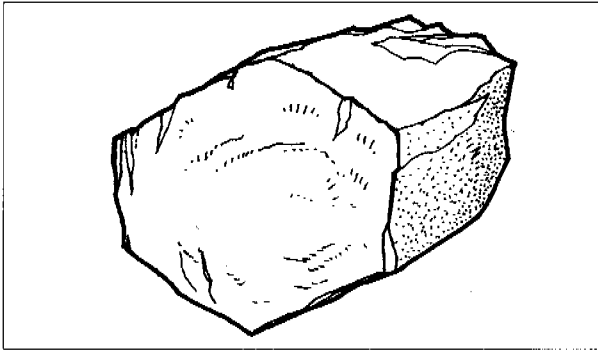
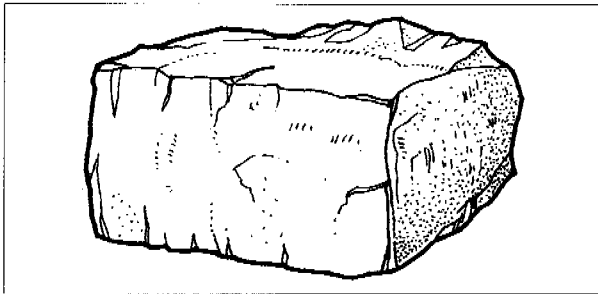

Stones built between corner stones are called line stones. They should be (but not necessarily) plain surfaced. The combination of plain surface corners and rough hammer dressed line stones give the stone masonry an attractive appearance.

Corner stone

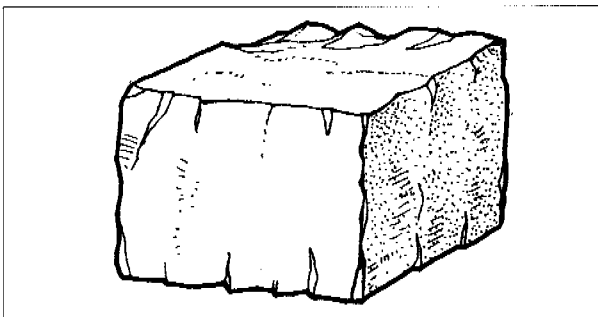

The two faces should be squared and shaped with chisel and club hammer to a plain surface, or at least hammer dressed to make accurate plumbing possible.

Arch stone

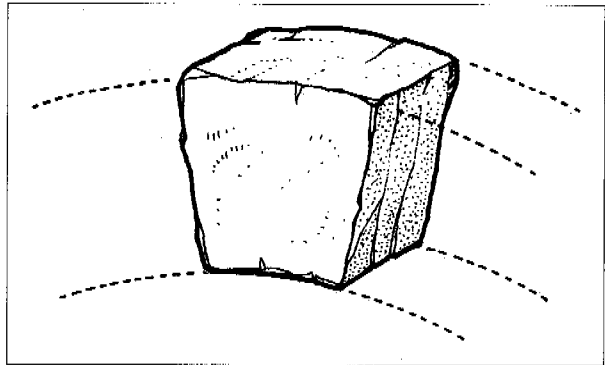

Unlike the cornerstone the arch stone is shaped like a wedge and is more difficult to shape than any other stone, because it has to be shaped to specific measurements.

Remark:

The commonly used stones are corner and line stones, the arch stone is not so common and needs a work intensive shaping. The preparation in advance of suitable cut and shaped stones is essential for all stone masonry work. Large quantities of squared two and three face stones as well as corner and line stones will greatly help the masons to find the suitable stone.

Rules for stone shaping:

- Workers shaping stones should always use eye protection glasses.
- All the stones should be of a size and weight that can be carried by one person.
- Select the stone and then choose the way you want to shape it.
- Cut it first roughly on all sides, if possible according to its natural shape.
- No angle of the face to side surface should be bigger than 90°.
- Dress the face straight and check it with a square or a straight edge.
- Select the stones which could be used as corners and shape the reverse face.
- During the supervision time while stone shaping the simple quality test should be regularly done as described in Chapter 2.1.3.

Remark:

Make sure that the quality of the shaped stones fulfill the requirements. Eye protection is extremely important for the workers shaping stones.

6.4.2 Stone masonry

There are different kinds of stone masonry possible. For water supply structures like storage tanks and chambers only uncoursed rubble masonry is recommended. Coursed or squared-uncoursed stone masonry (similar to bricks) need a very precise shaping and are therefore not appropriate because of the precise specifications and work intensive shaping.

Uncoursed rubble masonry

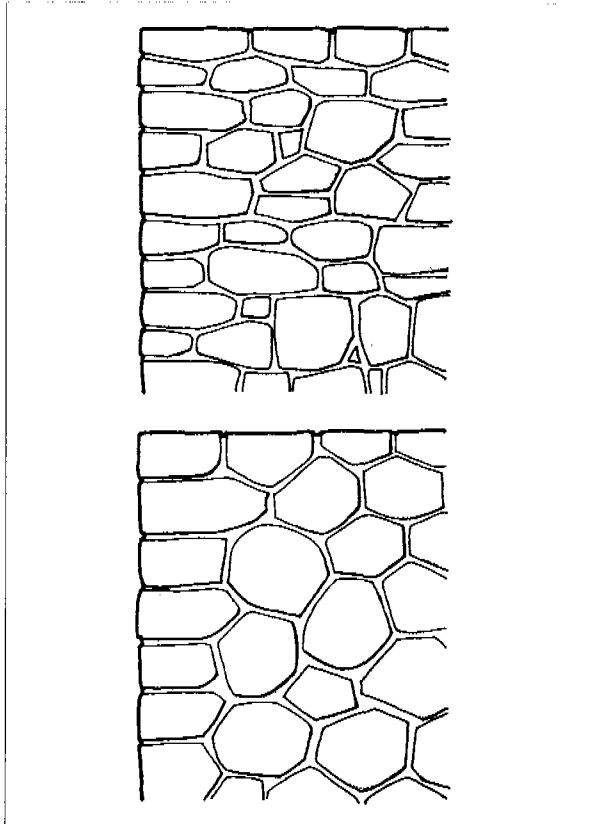

Uncoursed rubble masonry needs relatively little shaping and less precise jointing work. The layout and building of the structure will show clearly the builder's skill. Therefore, it is important to train builders in the special subject of stone masonry work. This kind of stone masonry uses all sizes of stones whose faces, joints and beds are roughly shaped. No attention is given to maintain level courses.

Coursed or squared-uncoursed masonry

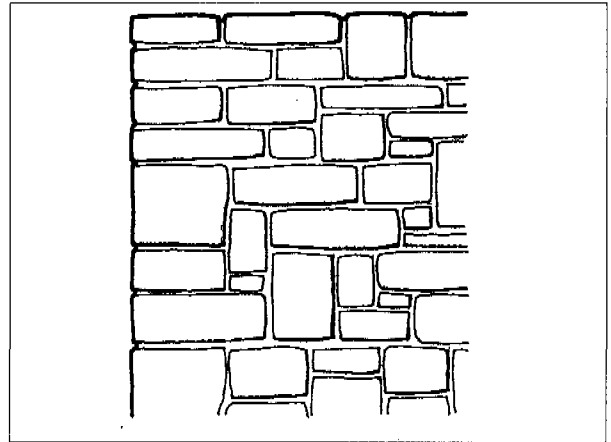

The rules for plumbing and lining are the same as for brick laying. It is advisable to hang one line for the inner wall and to work with two masons at the same time. One mason builds on the outside, the other on the inside of the line.

Advantages of stone masonry:

- local available building material
- high quality if properly selected and shaped
- mostly traditional building material of the region

Disadvantage of stone masonry:

- needs about 1.5 times more cement and sand for construction than brick masonry
- labour intensive cutting and shaping
- difficult to transport
- can cause erosion if not properly extracted
- dangerous for workers who cut and shape the stones (eye and other accidents)

The rules for good construction in uncoursed stone masonry work are:

A. Preparation

- a. Layout exactly the proposed structure by marking the external side of the walls on the foundation (Chapter 3.3.4).
- b. Clean the foundation with a steel brush, wet it properly, if necessary rough it by chiselling
- c. Two masons should work at the same time on a wall, one inside and one outside the wall.
- d. Use crack-free and washed stones

- e. Stiff mortar should be used. Never fill the inside of the wall with slurry mortar because this will reduce the strength.

B. Construction

- a. Use two-faced shaped and squared stones for corners as well as for the top of the wall.
- b. Use the largest and straightest stones on the ground and as corner stones.
- c. The stones should be laid on a mortar bed and then knocked in the mortar with a hammer.
- d. Build the cornerstones inside and outside, make also the back filling, then hang 2 lines on each side and build in between the lines.
- e. The left over mortar after each layer should be cleaned from the stones as well as from the ground so that it can be reused.
- f. The overlap of the stones should be a minimum of 10cm.

- k. 4 joints should never come together at the face of the wall. Straight joints longer than two stones should be avoided.
- l. Every third stone horizontally and vertically should be a binder. The length of the binders should be at a minimum $\frac{2}{3}$ of the thickness of the wall.
- m. The top of the wall should be built with shaped stones which are properly bonded into the rest of the wall.

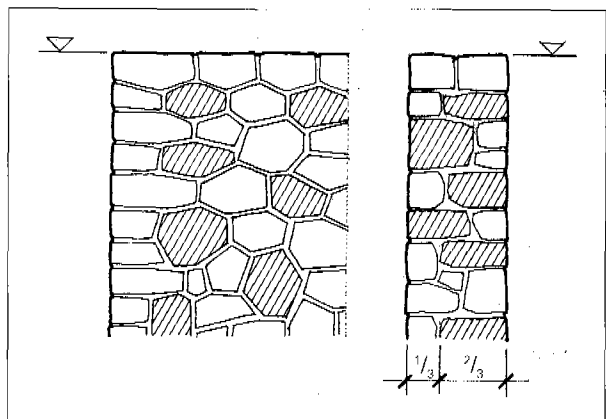
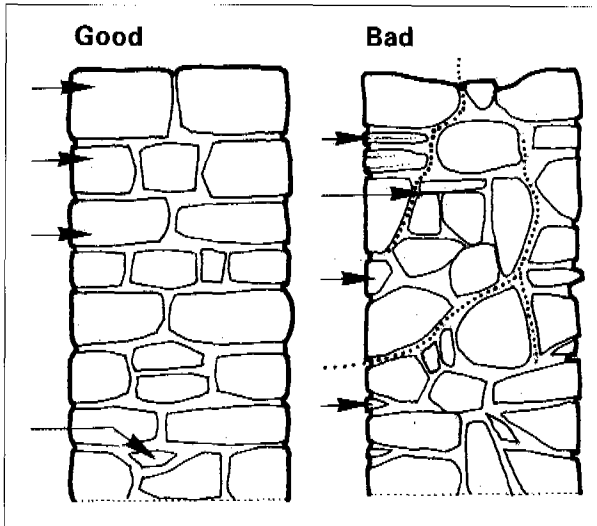
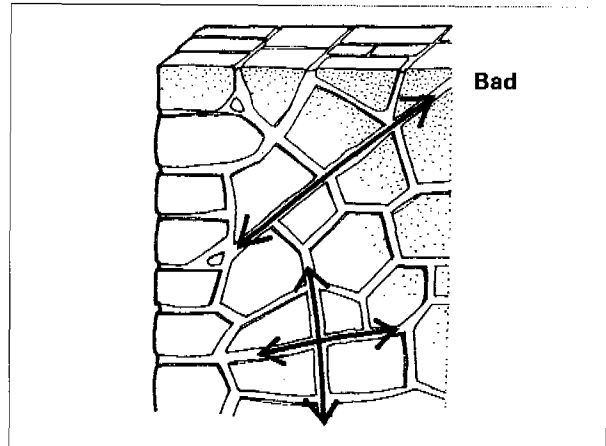

- g. The face and the inner part of the wall must be built at the same time.
- h. The joints should not be thicker than 2.0–2.5 cm but never less than 1.0 cm, depending also of the size of the stone.
- i. Small pieces of stones are used for better seating of shaped stones but they should not be visible at the outside of the wall. It is important that the small pieces of stones are well bonded with mortar all around.



7. Concrete Work

7.0 General

Where conventional building materials like stone masonry, brick masonry, timber etc. do not fulfill the requirements, or are not available a concrete construction is the only other solution. Therefore, concrete has a large range of applications. It is most suitable where high comprehensive strength is required. In combination with steel a high tensile strength can be achieved. Concrete work requires a special and different work procedure. Each necessary step to produce concrete is of importance for the quality of the end product.

7.1 Concrete

7.1.0 General

Concrete means a mixture of cement, water, fine and coarse aggregates (sand and gravel). The quality of concrete depends on the requirements being maintained for the aggregate as described in Chapter 2.2.2 Testing. Additionally important are mixing, water cement ratio, transporting, placing and compacting as well as curing.



7.1.1 Aggregates

Sand and gravel need to be clean (see Chapter 2.2.2) and in the required granulation as described before. If there is too much sand or silt the surface of the aggregates is increased and the cement has to bind this larger surface together. Therefore, with too much sand or silt more cement is required or the strength of the concrete is reduced. Too much gravel causes spaces inside the concrete, the workability is reduced, and proper compacting is not possible.

Good composition

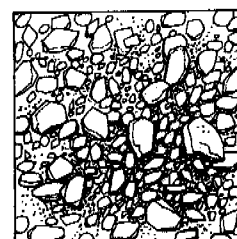

Too much sand

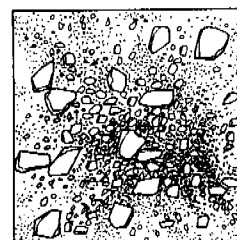

Too many stones

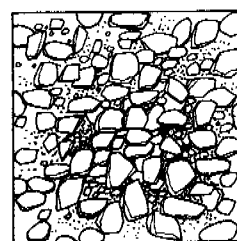

If possible use coarse grained sand and never the fine sieved sand used for masonry work. Reminders of coarse sand from sieved masonry sand can be added to the aggregates when mixed with coarse grained sand.

To obtain a proper granulation the components of grains should be within the range shown in the following chart. The test itself is described in Chapter 2.2.2.

The test (sieve analysis) should be made by a trained laboratory assistant or an experienced person. In properly made concrete each particle of aggregate, no matter how large or how small, is completely surrounded by cement paste and all spaces between the aggregate particles are filled with the paste.

In a well graded mixture the portion of large grains should be higher than the portion of medium grains, and the portion of medium grains should be higher than the portion of fine grains.

The quality of the concrete is reduced in the following cases:

Too much sand:

Enlarges the surface and therefore causes porosity, resulting in reduced compressive strength and density (not waterproof).

Too much gravel:

Causes large spaces and therefore reduces the compressive strength and density (not waterproof).

7.1.2 Water

Water in the concrete mixtures serves two purposes:

- First to take part in the hydration reaction (setting and hardening) of the cement.
- Secondly to make the mix fluid and plastic enough so that it can be easily worked and placed.

The quality of water that is fit for drinking is also fit for mixing concrete. The consistency of concrete is influenced by the amount of water added.

The plasticity varies according to the amount of water added as well as according to the amount of water contained in the aggregate.

7.1.3 Water-cement ratio

The water-cement ratio is an important factor in concrete mixtures. Not only the workability of concrete, but more importantly the strength depends on this ratio.

The water-cement ratio also depends on the porosity and moisture content of the aggregates. If the aggregates are wet

(sand out of the river/rainy weather), the amount of water added has to be accordingly reduced.

The natural moisture of aggregates varies according to the weather conditions as shown below:

Weather	Sand	Gravel
dry season	25–30 l/m ³	35–10 l/m ³
rain & sun mixed	70–80 l/m ³	25–35 l/m ³
rainy season	160–170 l/m ³	70–80 l/m ³

Therefore, the water content in a concrete mixture includes the mixing water as well as the natural moisture of the aggregate.

The best results for strength and density are achieved by using a stiff plastic mixture with a water-cement ratio of 0.5 (1:2) or less.

$$\text{water-cement ratio} = \frac{\text{water in kg (litre)}}{\text{cement in kg (litre)}}$$

Remark:

Only half of the water in the mixture is required for the chemical reaction. The rest will remain or evaporate gradually as the concrete hardens, leaving small holes. Not surprisingly holes weaken the concrete and so the more excess water there is in a mixture, the weaker will be the concrete.

7.1.4 Concrete mixtures

The mixtures of concrete are usually expressed in "PC" which gives the amount of cement required to produce 1.0 m³ finished concrete of specific quality. For example PC 300 means that 300 kg of Portland cement per 1.0 m³ finished concrete is used (cast and compacted).

The mixtures can be calculated by one of the following two methods:

a. Volumetric method

The mix-method for small quantities (hand mixes) is the so-called volumetric ratio cement : sand : gravel method. It is commonly used at village water supply construction sites.

For example the ratio 1 : 2 1/2 : 4 means that 1 part cement and 2 1/2 parts sand and 4 parts gravel are used for the mixture.

b. Weight method

Concrete mixtures are also expressed in kg of cement per 1.0 m³ of concrete. For example PC 250 means that 250 kg of cement, ~1000 litres of sand and gravel, and 120 litres of water are used to produce about 1.0 m³ of concrete.

According to the mixture are produced the following types of concrete:

a. Lean concrete (PC 100–PC 150)

This type of concrete is used in a stiff consistency for filling or surrounding purposes, and to create a clean bed to protect steel reinforcement from the soil. Lean concrete is rammed.

b. Unreinforced concrete (PC 200–250)

This type of concrete is used in a plastic or medium consistency for structural parts with moderate strength requirements like for small

foundations, pillars and floor slabs etc. Good compacting of unreinforced structures guarantees a strong and long lasting concrete. Unreinforced concrete is rammed.

c. Reinforced concrete (PC 250–350)

Reinforced concrete is of plastic or medium consistency.

This type of concrete is used for structures with high demands on compressive and tensile strength. Pillars, lintels, beams and slabs are only a few to be mentioned. Compacting with suitable tools or a vibrator is very important.

The required concrete mixtures should be described in the construction plan. Common mixtures used at village water supply structures are shown in the following table:

PC	Part cement	Part sand	Part gravel	Quality of concrete
100	1	6	9	Lean concrete
150	1	4	6	Lean concrete
200	1	3	5	unreinforced concrete
250	1	2 1/2	4	reinforced concrete
300	1	2	3	reinforced concrete
350	1	1 1/2	2 1/2	reinforced concrete

7.2 Mixing and processing of concrete

7.2.0 General

The correct mixture is an important first step in the processing of concrete, which also includes transporting, placing, compacting and curing. All these factors are very important and influence greatly the strength and quality of concrete.

7.2.1 Hand mixing



Hand mixing does not require much equipment, but a lot of man power. A batch to be hand mixed should not be larger than about 0.5 m³. Concrete should never be mixed on soil because of the proved danger of contamination by organic matters. A levelled platform has to be prepared to prevent water or fluid material from flowing out of the mixture.

The following points must be kept in mind when hand mixed concrete is foreseen:

- a. Concrete should always be mixed on a level and clean platform, which is sprinkled with water before mixing starts.
Suitable platforms are:
 - Concrete slabs / rock / moulds / or iron-sheets
 - It is recommended that for a large construction site perhaps a concrete slab should be made
- b. Spread the first layer (sand) and the second layer (stones) on the platform, then spread the cement on top.
- c. Mix the material dry until there is a uniform appearance. Therefore, at least three times of mixing necessary.
- d. The material is then shovelled into a flat heap with a hollow in the centre into which about half the required water is poured.
- e. Then the final step of the mixing procedure starts by shovelling the material from the edges to the centre, emptying each full shovel and then turning it over again. Add water as necessary to obtain required consistency as the material is turned over again.

Remark:

Setting time can start half an hour after pouring water into the mixture. Therefore, do not mix more than 0.5 m³ at once (10 wheelbarrows). If the concrete mixture is disturbed during setting time (if setting time has already started before the concrete is put in place and rammed or vibrated) it will cause loss of strength.

7.2.2 Machine mixing

There are a variety of mixing machines available. It is important to maintain these machines daily (including cleaning). Before the aggregates are put into the drum, the drum has to be sprinkled with water. The batch is to first mix dry, and after about 45 seconds the water should be poured in. The mix-

ing procedure continues for about another 45 seconds. Mixing more than about 1 and a half minutes does not improve the quality of the concrete, but is a waste of energy.

7.2.3 Processing of concrete

The processing of concrete can be divided into four phases:

Phase 1: Transporting

To avoid separation of aggregates keep the transport distance always as short as possible. Use tide buckets or pans so that the cement milk can not flow out during the transport.

Phase 2: Placing and casting

Before any concrete is placed, the form work needs to be checked for cleanliness, strength, tightness and alignment. It is essential to keep the form work wet and sprinkle with water before the casting starts. If the form work is not sprinkled the boards will absorb a large amount of water. This will negatively influence the chemical reaction during setting and cause a rough surface and a reduction in strength. The concrete should be placed in layers. Each layer must be compacted before the next one is put down. The following layer should be put down before the setting of the previous one has started.

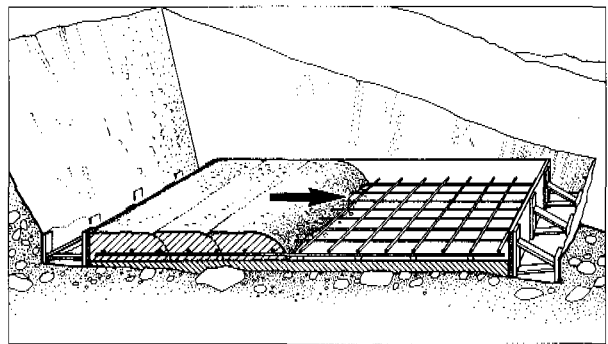

Phase 3: Compacting

After concrete is placed it contains entrapped air in the form of voids. The object of compacting is to get rid of as much as possible of this entrapped air. Voids reduce strength, waterproofness, and proper binding to the reinforcement. Insufficient compacting is visible on the concrete surface by the presence of large numbers of air bubbles and rock pockets. Compacting can be done by hand or with a vibrator. The vibrator should be operated by skilled people. The needle of the vibrator should not be brought too close to the formwork or the reinforce-

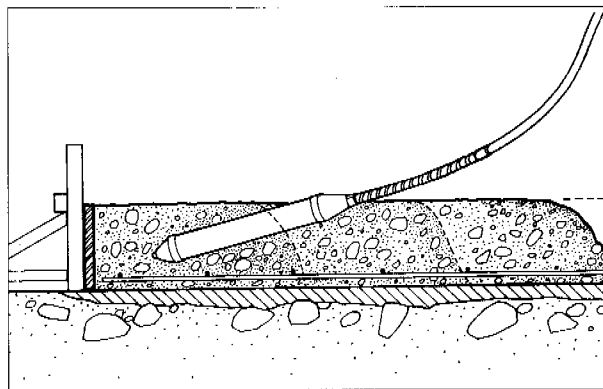

ment, to avoid vibration on the formwork or reinforcement. The vibration can cause holes and therefore weaken the structure.

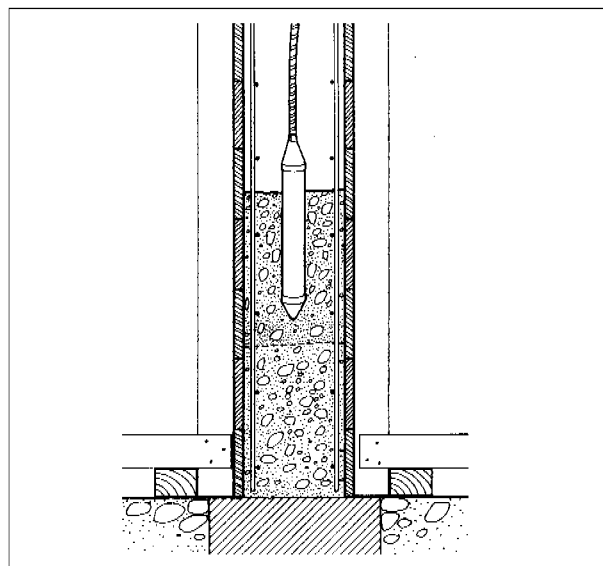

Phase 4: Curing

Curing is necessary to provide sufficient moisture to enable the process of cement hydration. Curing should be started at the very beginning of setting. The longer the period of curing, the better the quality of concrete. Therefore the minimum period of curing should be at least 7 to 14 days, depending also on the weather influences. Methods of curing are sprinkling or flooding of water, covering the sand, or empty cement bags or plastic sheets. If there is any danger of frost reduce the water curing and cover additionally with suitable insulation material like empty cement bags, grass, or wood planks etc.

7.3 Quality of concrete

7.3.0 General

Each different part of a structure may use a different strength of concrete. There exist several different methods to test the quality of concrete. The test procedures of these methods are quite complicated, and require a laboratory with expensive infrastructures. Therefore, in this manual only rough testing is described. For more and detailed information refer to Ref. 2 in the bibliography at the end of this manual.

7.3.1 Cube test

The concrete specimens are cast in steel or cast-iron moulds, which should conform to the cubical shape (generally a 150mm cube). The inside surface of the mould should be covered with a thin layer of mineral oil in order to prevent the development of bonding between the mould and the concrete. The mould is to be filled in three layers, whereby each layer is compacted by not less than 35 strokes of a 25mm square steel punner. After the top surface of the cube has been finished by means of a trowel, the cube is stored undisturbed under the same conditions as the structure to be built. After 28 days the cube is taken for the compression test. At this test the cube is placed with the cast faces in contact with the platens of the testing machine. The load on the cube should be applied at a constant rate of increasing stress. The crushing strength is then reported to the nearest 5kg/cm².

7.3.2 Rebound hammer test

The difficulties of core cutting, and indeed the entire procedure of making, curing and testing of standard test specimens would all be avoided if concrete could be tested in such a manner harmless to the part tested. One method that has found practical application within a limited scope is the rebound hammer test. It is also known as the impact hammer, or sclerometer, test.

The test is based on the principle that the rebound of an elastic mass depends on the hardness of the surface against which the mass impinges. In the rebound hammer test a spring-loaded mass has a fixed amount of energy imparted to it by extending a spring to a fixed position; this is achieved by

pressing the plunger against the surface of the concrete under test. Upon release, the mass rebounds from the plunger, still in contact with the concrete surface, and the distance travelled by the mass, expressed as a percentage of the initial extension of the spring, is called the rebound number. In relation to this number the strength of the tested concrete can be found. Multiple testing is required because the results may show considerable differences. This is the case where the hammer hits a stone or a point with only sand and cement. Therefore, it is recommended to perform at least at 5 different place the test and calculate the average to get a reliable idea of the concrete strength.

Remark:

For sophisticated structure in reinforced concrete the quality testing of the concrete is required. In general for water supply structures the testing of the concrete quality is not required. Still it is most important to fulfil the quality requirements described hereafter:

Compressive Concrete Strength Table

Amount of Cement per m ³ finished concrete (kg)	Compressive strength after		
	3 days (kg/cm ²)	7 days (kg/cm ²)	28 days (kg/cm ²)
150	31.5	49	70
200	49.5	77	110
250	72.0	112	160
300	99.0	154	220
350	126.0	196	280

7.4 Reinforced concrete

7.4.0 General

Concrete can support heavy loads in compression, but its tensile strength is relatively low, being about one-tenth of the compressive. On the other hand, steel has a very high tensile strength.

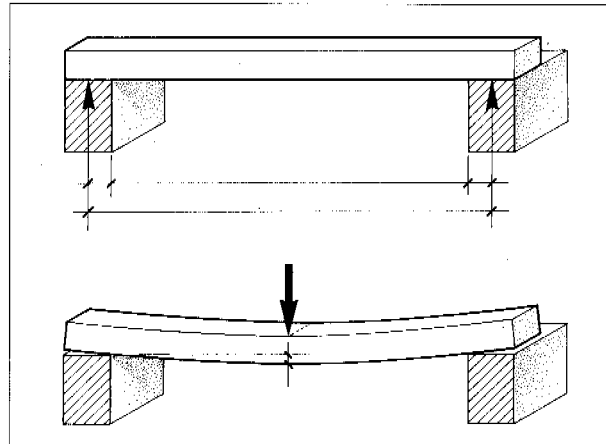

By embedding steel bars in the concrete, advantage is taken of these properties to improve the load carrying capacity of the structure. The steel is placed in the concrete that is subjected to tension but also to avoid cracks due to shrinking.

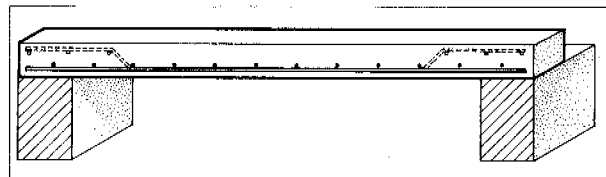

7.4.1 Reinforcement

There are two main categories of reinforcement by steel. The main reinforcement to take over the tension and the distribution reinforcement to spread the loads and to keep the main reinforcement in position during casting.

The main reinforcement should always be at the site where tension occurs. It should not be closer than 3.0 cm to the shuttering or the top, to avoid corrosion of the reinforcement. Steel bars of plain surface (mild steel) need to be hooked at the ends to obtain better adhesion, and therefore create a greater strength for the structure. Hooking is not necessary for steel bars with ripped surface (Thor steel).

A proper bond between the steelrods and the concrete is the most important supposition for reinforced concrete. The surface of the rod has to be clean and not to rusty. In order to provide a proper bond the rods have to be surrounded completely by the concrete. The reinforced concrete has to be vibrated with a vibrator. Plain bars must have ends with hooks which should be anchored in the pressure zone. Deformed bars with ripped projections can have straight ends but then the anchorage has to be in the pressure zone of the structure.

If rods have to be overlapped the following rules show the minimum overlap length:

rod with hook

45 times diameter of the rod

straight

65 times diameter of the rod

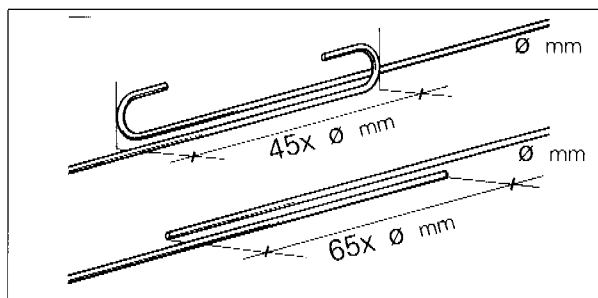

Remark:

The proper placing of reinforcement for structures of high quality concrete requires a working drawing or reinforcement plan, containing all the necessary information (see Engineering manual of this series).

7.4.2 Form work

Most structural concrete is made by casting concrete into spaces of previously constructed boxes called forms. Usually wall, column, beam and slab forms are build by joining boards edge on edge, sometimes plywood may nailed on setting since it is tighter and more wrap resistant. In certain cases metal forms are used, e.g. when a large number of equal structural members (precast elements) have to be erected or when the parts should be very exact in measurements.

The most suitable material for form work is wood, in particular boards, rails, batten and planks. All this timber is available in various quality and dimension. Hardwood should not be used for parts where nailing is necessary. Boards of less quality and boards of rough surface do not last very long as shuttering. The reuse

can be extended by using plastic or metal sheets.

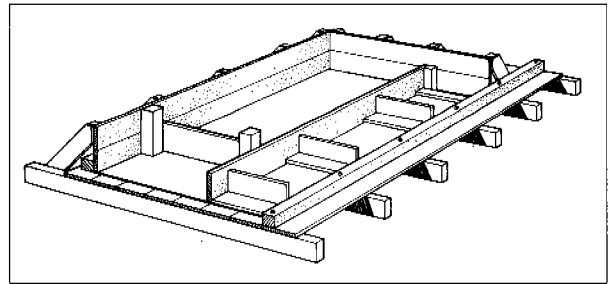

All form work material (planks, boards, steel etc.) and element form work (moulds) are sprinkled with water before placing concrete. After striking or dismantling, the form work is cleaned and eventually oiled as well as properly stored and protected from sun and rain. This will guarantee the use of many times.

Form work for precast products like cover slabs, fence posts, well and culvert rings, and element form work for standard structures like stand posts

should be made of quality timber or steel. The use of G.I. sheets as additional reinforcement for timber form work is very suitable because nailing of side boards or batten is still possible.

7.4.3 Precast concrete

Structural parts which are not possible to cast on site or which are more economical to prefabricate, are precast concrete products like:

- lintels
- manhole covers
- slabs
- rings
- pools etc.

The consistency, mixture and reinforcement of precast concrete depends on the purpose and/or transporting facilities. The procedure of precast concrete is the same as for other concrete. It is important to have sufficient working and storage space and a proper follow up treatment like curing. No removal during setting and hardening time, as well as good weather protection are essential. The local stores may have some of the prefabricated products like lintels. Therefore, it is to be decided if locally made products are fulfilling the requirements.

Advantages of precast concrete:

- fast production
- high quality
- economical use of shuttering
- cheap

Disadvantages of precast concrete:

- transporting to the site
- exact working at the construction site because no adjustment is possible

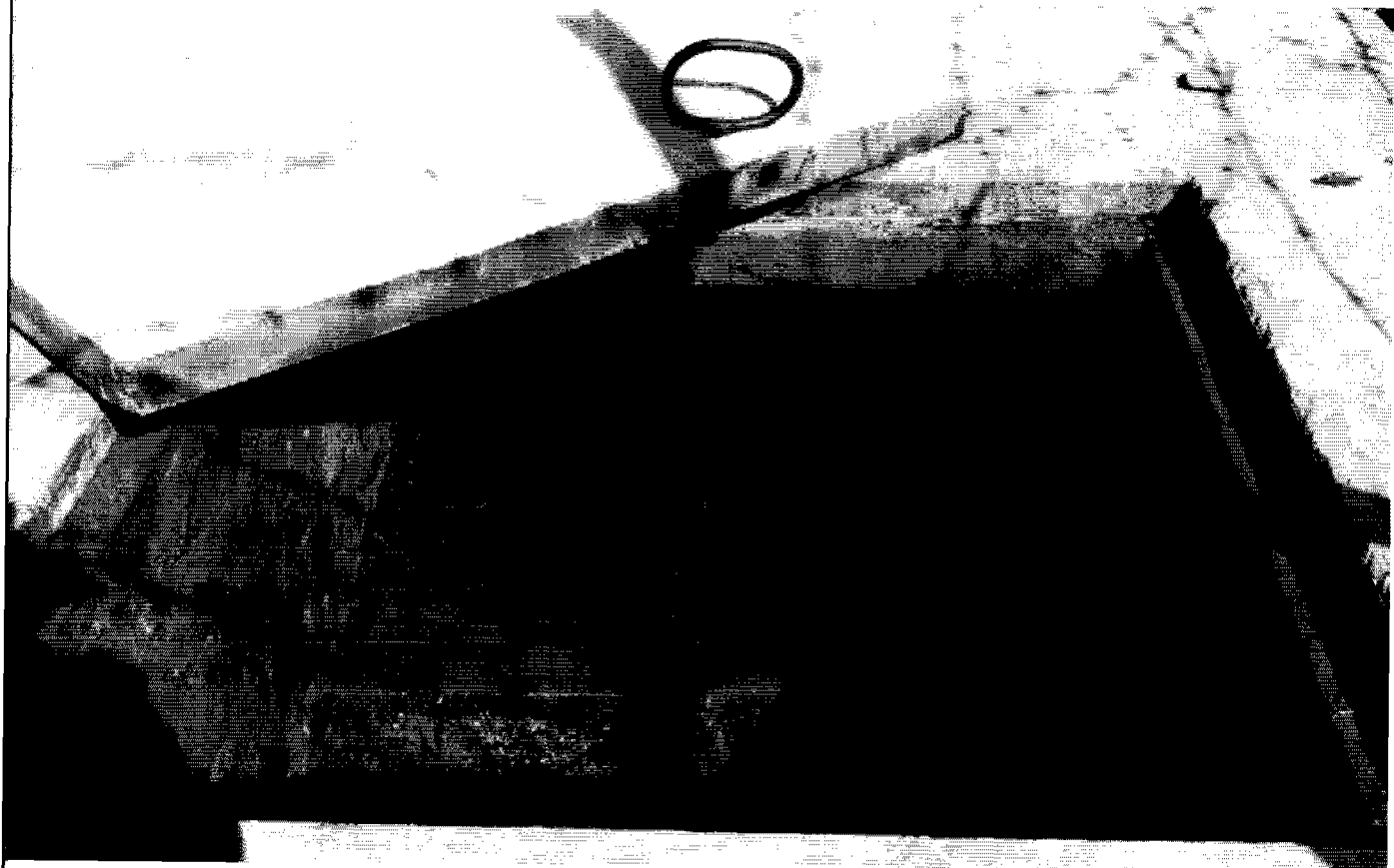

8. Construction of a Masonry Tank

8.1.0 General

There are many different layouts of tanks possible, like round or rectangular ones. Important for the layout is the proper water circulation from the inlet water to the outlet water. It is essential that there is no standing water in the storage basin, otherwise the quality of the drinking water is not guaranteed. The construction of round tanks is especially because of the roof construction more sophisticated and therefore in this manual not described. The width of the tanks is limited to about 2.5m because of the roof construction with precast concrete slabs. The size and therefore the weight of these slabs is limited by the requirement that they still can be put in place without technical help. This type of construction has been successfully tested over years and has been found to be suitable for many water supply projects all over the world.

This manual looks mainly at the building part and procedure of the storage tank, whereby the manuals *Engineering* and *Storage and Distribution* go into the details of construction and arrangements of storage tanks.

8.1.1 Site preparation

Before the construction of the tank is started the following preparation work needs to be done:

- Preparing the required material according to the construction plan.
- Excavation of the tank side
- Setting out of the structure

8.1.2 Construction

The construction of a 10 m³ tank for example can be divided into the following steps:

1. Casting and compacting the 20cm thick foundation in concrete PC 250 with welded mesh on top and on bottom. At this tank design the supply, washout and overflow pipe is cast into the slab.

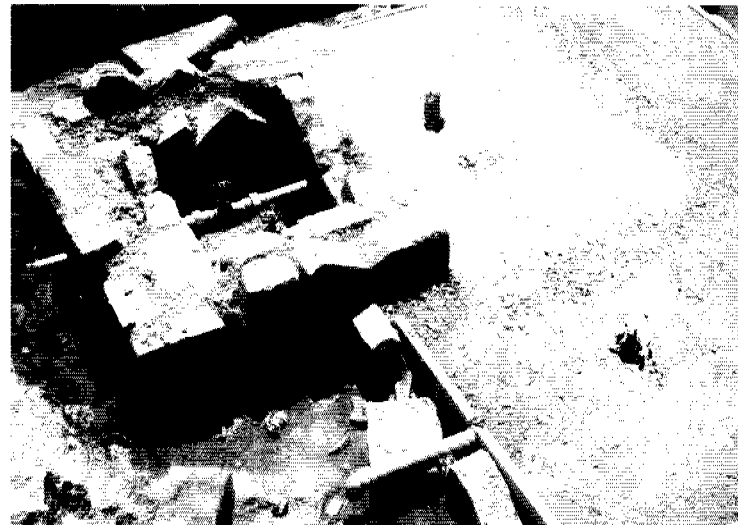

2. Building the wall according to the required bonding.



3. During construction of the wall the precast slabs should be cast. For the 10 m³ tank there are 6 slabs with the dimension 74*190*6cm required. The schedule for casting the slabs should be chosen that the last slab is finished at least 20 days before they are going to be put on top. Otherwise the strength of the slab is not according to the requirements (see also Chapter 6.3).
4. As soon as the wall construction is finished the plastering to make the tank waterproof can be started. This procedure requires a stop of the

work at the tank site for at least 10 days (setting time of spaterdash). Therefore, during this time the construction work of other parts of the supply can be started.



5. During the time of plastering the pointing of the outside wall can be done.



6. As soon as the plastering is finished the tank should be filled up with water for about one week to test if it is watertight.

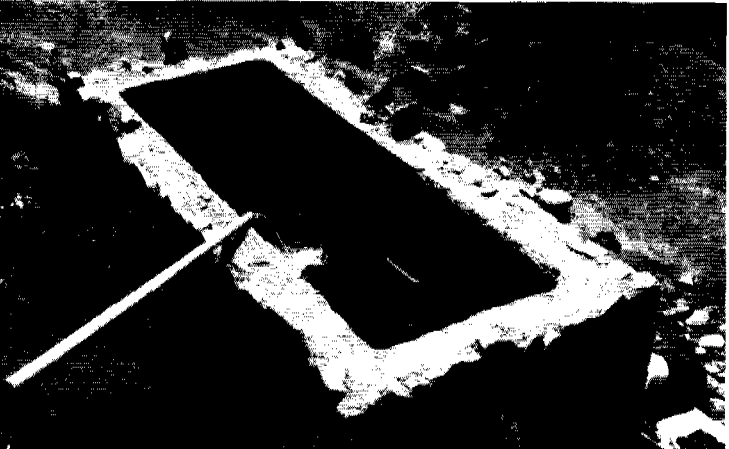

7. The last construction part of the building is to cover the tank. Therefore, the precast slabs are put in place. One special designed cover with an opening for a tank with a manhole (for maintenance reasons) is put at the side where the supply washout and overflow installations are.

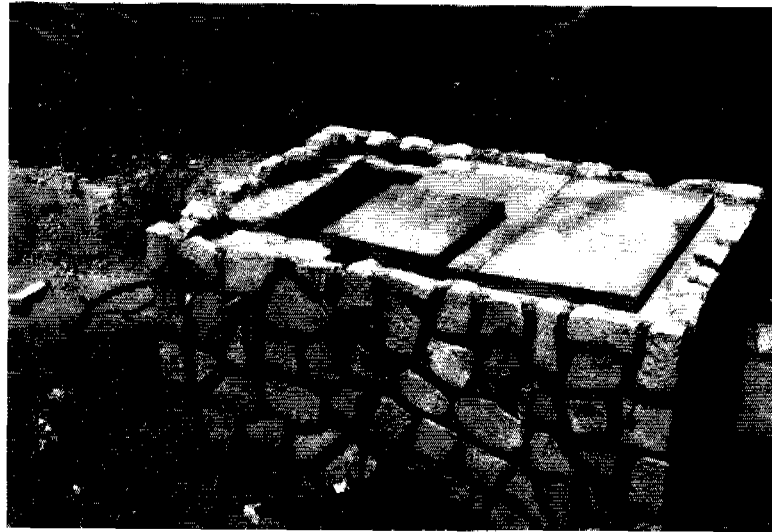

8.1.3 Finishing work

The storage tank is after the spring chamber the most important building of the water supply. Therefore, the finishing work at the surrounding should be done most carefully. The detailed arrangements around the tank site are described in the manual the supply system.

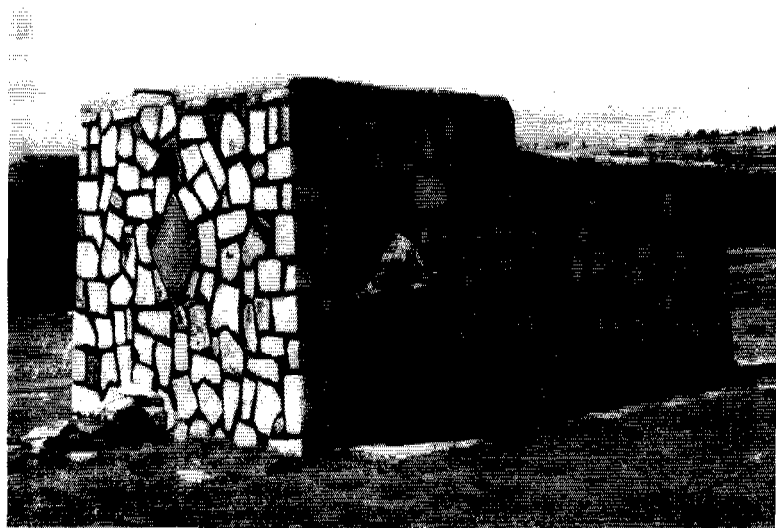

Reference Books

- Ref.1 - Appropriate Building Materials, SKAT
1981/1983/1993
- Ref.2 - Properties of Concrete A M Neville
(Longman Scientific & Technical)

VOLUME	1	Management Guide
VOLUME	2	Engineering
VOLUME	3	Building Construction
VOLUME	4	Spring Catchment
VOLUME	5	Hand-dug Shallow Wells
VOLUME	6	Drilled Wells
VOLUME	7	Water Lifting

What you should know about this series of manuals:

It is a guide for	project managers, engineers and technicians
	but is also useful for all other actors in the sector
with a focus on	community based managed systems (predominantly in rural areas)
	water supply
	technologies
with an emphasis on	a balanced strategy including technical, social, institutional, economic and regulatory aspects for the
	achievement of sustainability
providing options for	management
	strategies and approaches
providing linkages to	sanitation and health
limited to	experience in Swiss-supported projects, taking account of new developments
does not cover	sanitation
	drainage
	solid waste management
Volumes 2 to 7	should be used in conjunction with Volume 1