

232.0 92TE

INTERNATIONAL REFERENCE CENTRE
FOR COMMUNITY WATER SUPPLY AND
SANITATION (IRC)

WATER and ENGINEERING

technical information bulletin

No. 005

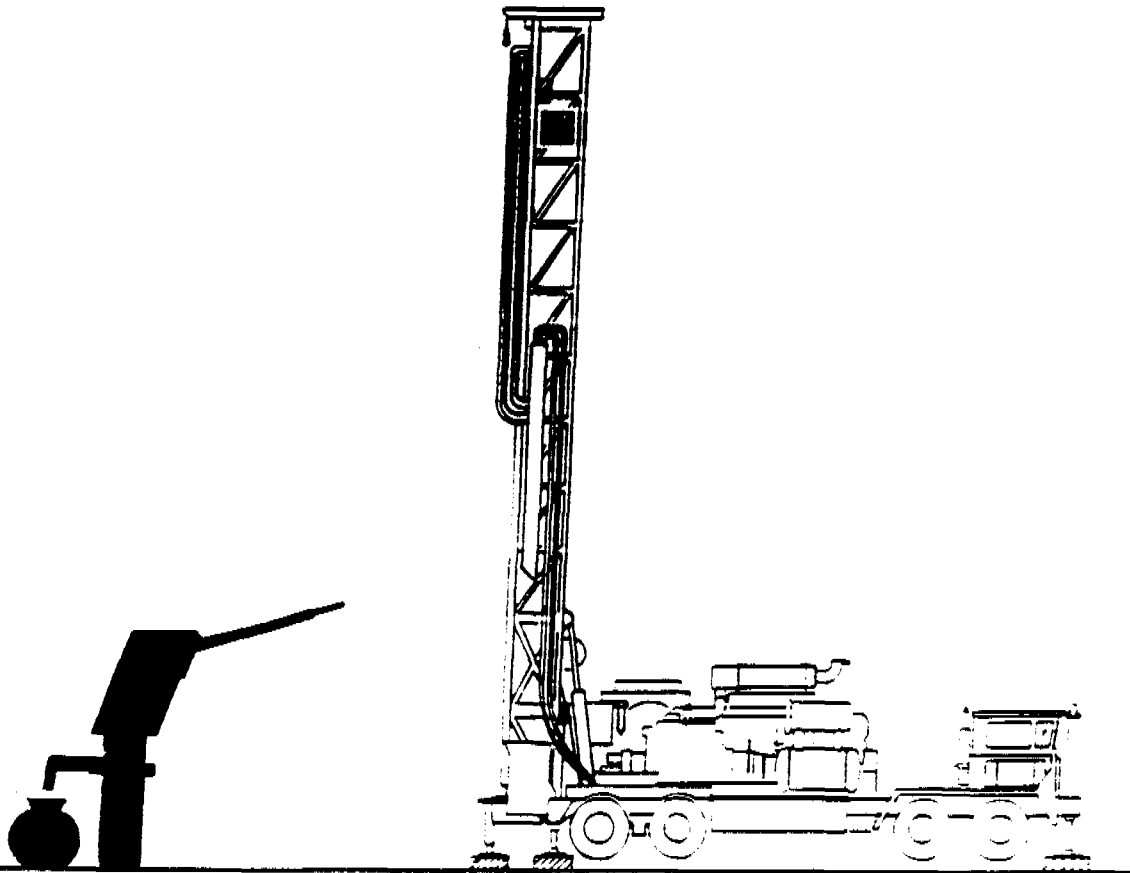

Date : 2 March 1992

TEST PUMP UNITS

Attached are three specifications of Test Pump units, the smallest of which is mounted on a skidframe is portable, suitable for storage inside a Landcruiser or on the back of a pickup van. This small test pump unit is designed for a 2 inch diameter pump and can also be utilized for other purposes such as small water sample taking, etc., since the pump flow can be accurately controlled.

The largest unit has a pumping capacity of 50 m head - 32,000 l/hr and yet is suitable for towing behind a light weight 4-wheel drive vehicle.

A new instrument which automatically and continuously measures draw-down and flow, while pumping, is called the "AquaMEMO". (Specifications for this instrument are included on the last page). The advantage of this instrument is that it can be mounted on the test pump unit and collects all necessary data, such as draw down and flow, continuously. By using a standard IBM compatible computer, i.e. a laptop, the data can be interpreted with the use of an interpreter programme, which can easily be installed into the computer.

A special field computer, with a test pump programme already installed on the hard disc, can be purchased for USD 4,800.-. It is an advantage to have a separate field computer as it will always be available on site and the interpretation of the test pumping can be done immediately to determine the well's and aquifer's capacities.

All the costs shown in the attached specifications are for budgetary purposes and when an actual procurement action based on international bidding is taken a cost reduction is anticipated.

TYPE 1

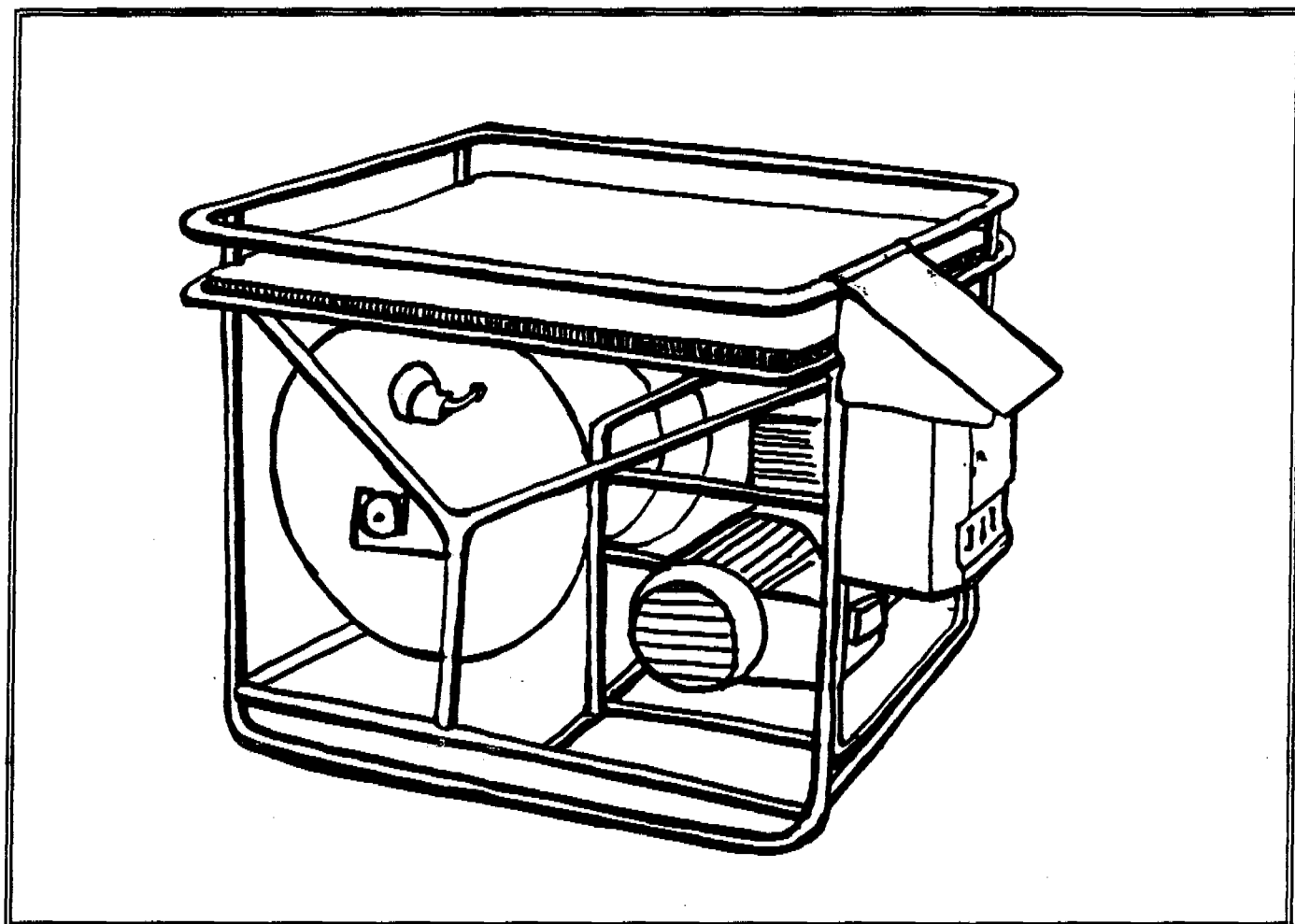

Test pump unit for shallow water wells down to an average depth of 50 m.

Maximum pumping depth: 90 m.

Pumping capacity at 90 m lifting head: 400 l/hr.

Pumping capacity at 30 m lifting head: 1200 l/hr.

The test pumping unit is mounted on a light weight protecting frame.

Power source is from a one cylinder 4-stroke petrol engine which is powering an alternator at 2 kVA.

Voltage: 220 V

Phase: Single

Frequency: 50 hz.

(Type 1 continued)

The unit is equipped with a manually operated cable reel with a capacity of 100 m 1.5 sqmm electrical cable.

The complete unit is built for manual operation and suitable for storage inside a light weight vehicle e.g. Toyota Landcruiser or can be mounted on a single axle trailer for towing behind a similar light weight vehicle.

Weight of skid mounted unit: 50 kg.

Cost of complete unit including 50 m. 1" dia. flexible discharge hose, two submersible pumps of 2" dia. and 90 m. electrical cable. USD 19,500.-.

This test pump unit can also be used for other applications such as small sample taking and to pump out oil or similar lying on top of the water in the well.

By regulating the flow through a frequency regulator the test pump can be used as a service pump in addition to a normal test pump function.

On several occasions, due to the type of drilling used, it happens that lubrication oil, i.e. using D.T.H. hammer drilling, is left in the well. The oil is lighter than water and is flowing on top, to get the oil out of the well one must do a thorough well development. By using this pumping unit one can start the by pumping out the oil without interfering with the water yield and the well development will become easier.

TYPE 2

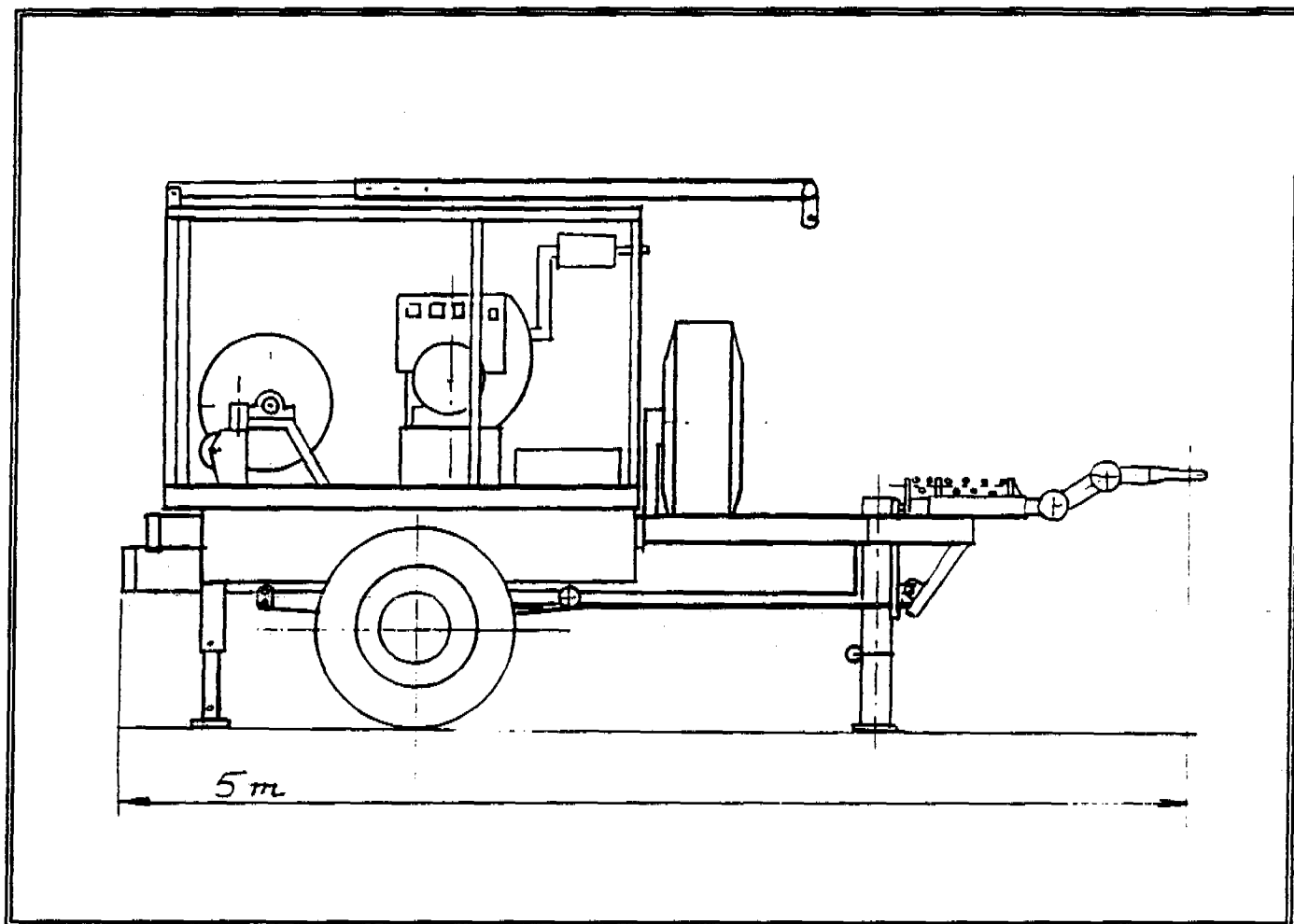

Test pump unit for 4" or larger diameter water wells down to an average depth of 90 m.

Maximum pumping depth: 140 m.

Pumping capacity at 140 m. lifting head: 1000 l/hr.

Pumping capacity at 90 m lifting head: 5000 l/hr.

The test pumping unit is mounted in a single axle trailer suitable for towing behind a light weight vehicle.

The power source is from a two cylinder aircooled Lister diesel engine model TR2, which powers an alternator of 10 kVA at 1500 rpm.

(Type 2 continued)

Voltage: 380 V.

Phase: 3.

Frequency: 50 Hz.

The unit is equipped with a hydraulically operated winch with a capacity of 1000 kg. pull.

The winch line is via a manually erected tripod lowering and lifting the submersible pump and the riser pipes in the well.

A manually operated cable reel, complete with 150 m. 4.5 sq mm. electrical cable, is also mounted on the test pump unit.

The complete unit is covered with a weather protecting canopy and has lockable tool boxes and pipe rack for storing during transport. The weather protection canopy has top hinged doors which gives easy access to the operating panel and all connectors.

A working light is mounted at the rear of the test pumping unit.

The manually operated tripod can be stored on the top of the test pump unit during transport.

Weight fully loaded with 90 m of pipes: 2500 kg.

Cost of complete unit including 90 m of 1 1/2" dia. rising pipes in 3 m. lengths, two 4" dia., one is a spare, sand-resistant submersible pumps: USD 45,000.-

TYPE 3

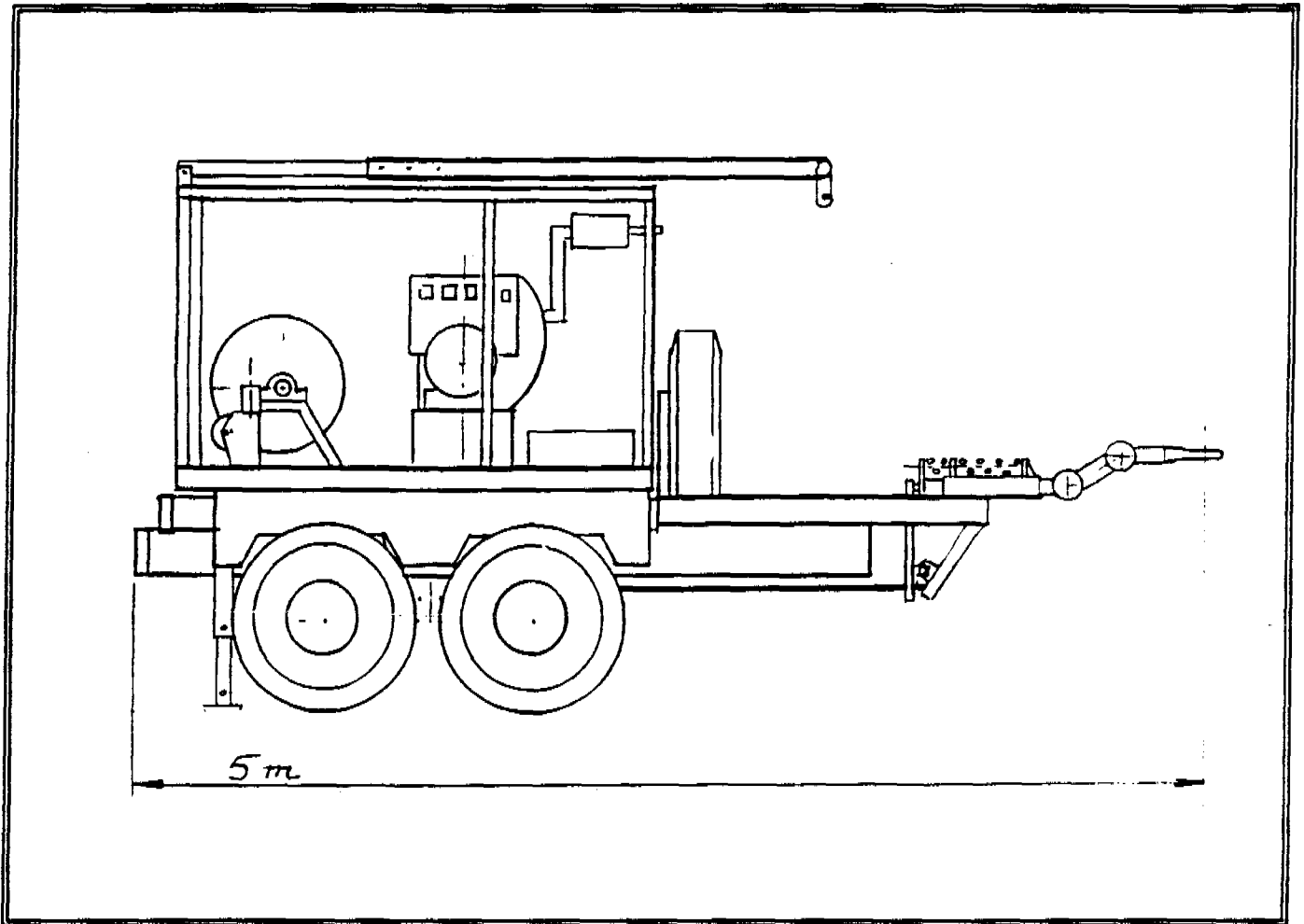

High volume capacity test pump unit for 4" or larger diameter water wells down to an average depth of 90 m.

Pumping capacity at 90 m. lifting head: 14,000 l/hr.

Pumping capacity at 50 m. lifting head: 32,000 l/hr.

The test pump unit is mounted on a two axle boggy type trailer with heavy duty towbar suitable for towing behind a light weight vehicle.

The power source is form an aircooled Deutz diesel engine model F3L 912, which is powering an alternator of 28 kVA at 1500 rpm.

(Type 3 continued)

Voltage: 380 V.

Phase: 3.

Frequency: 50 Hz.

The unit is equipped with a hydraulically operated winch with a capacity of 1500 kg pull.

The winch line is via a hydraulically erected tripod with a height of 4 m. above ground lowering and lifting the submersible pump and the riser pipes in the well.

A manually operated cable reel complete with 100 m. 7x4.5 sqmm. electrical cable is also mounted on the test pump unit.

The complete unit is covered with a weather canopy and has lockable tool boxes and pipe rack for storage during transport.

The weather canopy has top hinged removable doors which give easy access to the operation panel and all connectors.

A working light is mounted on the rear of the test pump unit.

The hydraulically operated tripod can be folded and stored on top of the test pump unit during transport,

Weight fully loaded with 90 m. of 2 1/2" pipes: 2900 kg.

Cost of complete unit including 70 m of 2 1/2" rising pipes in 3 m. lengths, one 4" dia. and one 6" dia sand-resistant submersible pumps: USD 73,000.-

MEASUREMENT WHILE TEST-PUMPING

A pumping test should serve two main objectives. Firstly, a pumping test may be performed in order to determine the hydraulic characteristics of aquifers or water-bearing layers. Secondly, a pumping test may provide information about the yield and drawdown of the well.

When performing pumping tests, water is pumped from a well during a certain time and at a certain rate. The drawdown in the same well, and occasionally others in the vicinity, is measured. This data collecting system automatically records the drawdown in the well(s) via pressure transducer(s), at the same time as the flowrate and time is recorded.

When interpreting the measurements, the most widely used models for describing the aquifer can be used. The well type can be the pumped well or an observation well. Calculated values may be storage coefficient, transmissivity, leakage factor, anisotropy, or specific yield (depending on model type).

A new system, AquaMEMO, for automatically recording and interpreting/presenting test-pump data has been, for the last 3 years, thoroughly tested under the worst possible working conditions in Scandinavia and in the Far East.

The AquaMEMO system is a low-cost system meant to be mounted on small test-pump units. The system is sufficient, in most cases, where only test-pumping is concerned. The system consists of:

1. One pressure transducer and a connecting cable. Measuring range 0-150 m.
2. One flowmeter module of very high quality. Measuring range up to 20 m³/h.
3. A small size, weather-proof XT-computer including:
 - Three different modes: LOG, DATA OUT, DATA IN.
 - Four input lines for pressure transducers and/or flow-meters.
 - Four digital alarm-output-lines. Example: if the water table drops below a preset value the pump is automatically shut off until the water table has increased again.
 - Real time clock for setting of measurement interval (can be altered automatically during measurement).
 - LED-display showing pressure (depth of water table) and flow rate (which could then be set accurately).
 - Current input 12 VDC, one serial port, one parallel port.
 - Battery for stand-alone operation (10 h).
 - Data transfer software to "lap-top" computer or directly to printer.

PRICES

- Total price for the above system is USD 14,570.-
- Price for interpretation programs is USD 1,640.-
- High quality lap-top computer with math co-processor is USD 4,910.-
- Price for additional pressure transducers and/or flowmeter can be quoted on request.