

2 7 2 . 2

8 0 S M



Deutsches Zentrum für Entwicklungstechnologien
Centre allemand d'inter-technologie appropriée
Centro Alemán para Tecnologías Apropriadadas

an Appropriate Technology Exchange

in

Deutsche Gesellschaft für Technische Zusammenarbeit (GTZ), GmbH

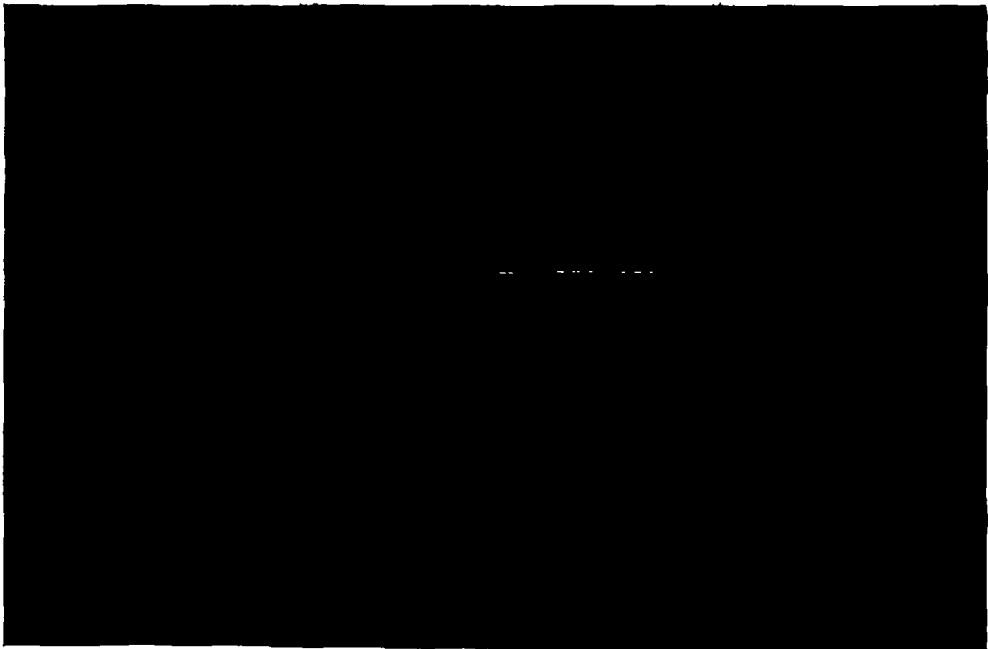

272.2-80SM

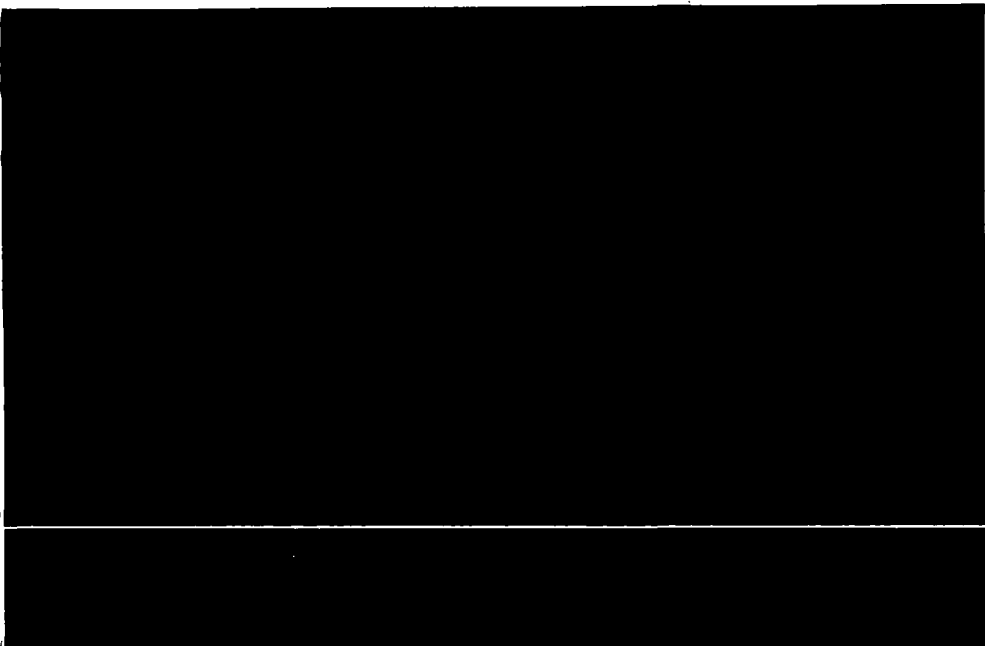

GATE is part of

Deutsche Gesellschaft für
Technische Zusammenarbeit (GTZ) GmbH

Dag-Hammarskjöld-Weg 1, D-6236 Eschborn 1,
Telefon (06196) 4011, Telex 417405 (GTZ)

1066
272.2
805M



Deutsches Zentrum für Entwicklungstechnologien
Centre allemand d'inter-technologie appropriée
Centro Alemán para Tecnologías Apropriadas

German Appropriate Technology Exchange
in Deutsche Gesellschaft für Technische Zusammenarbeit (GTZ), GmbH

Deutsche Gesellschaft für Technische Zusammenarbeit (GTZ), GmbH
Postfach 5180, D-6236 Eschborn 1

PUBLISHED BY

German Appropriate Technology Exchange (GATE)
in: Deutsche Gesellschaft für Technische
Zusammenarbeit (GTZ), GmbH
Postfach 5180, D-6236 Eschborn 1,
Federal Republic of Germany

PREPARED BY

Albert Breuer
Axel Netzband

SMALL - SCALE - IRRIGATION

QUESTION - AND - ANSWER - SERVICE

for "appropriate technologies"

The question-and-answer-service - a major service provided by GATE - supplies information, free of charge, on appropriate technologies. In performing this function, GATE is part of an international information and documentation system called SATIS (Socially Appropriate Technology Information System), in which ITDG (Great Britain), TOOL (Netherlands), ATOL (Belgium), VITA (USA), GRET (France) and SKAT (Switzerland) also participate.

The question-and-answer-service is made available to public and private institutions and selected persons in developing countries who are concerned with the development, adaptation, introduction and application of appropriate technologies. With this service GATE is aiming to supplement commercial private-enterprise activities by making a contribution to non-commercial technology transfer, particularly in the field of traditional, intermediate and alternative technologies. In addition to technology transfer from industrialized nations to developing nations, particular attention is given to cooperation between the developing nations themselves.

The activities of the question-and-answer-service are geared to the actual technological requirements indicated by the enquiries received from developing countries. At the same time, the demand for particular solutions is determined with the aid of a questionnaire distributed to institutions in developing countries dealing with situation-related solutions. Parallel to this, the questionnaire also makes it possible to ascertain solutions already available within these institutions. The question-and-answer-service relies not least on the documentation on newly-developed or traditional technologies supplied to it by such possessors of know-how.

When answering enquiries the question-and-answer-service uses documentation resources built up in this way. The information accumulated there on particular technological problem areas is - if frequently requested - combined to form "modules".

These answer packages, intended for dispatch, contain, where possible, technical descriptions and design drawings and are thus directly application-related, i.e. they provide an outline of technologies suitable for self-construction. The know-how of national research institutions and universities, with whom GATE works in close cooperation, is drawn upon to help answer specific enquiries, which can often be expected as feedback from the communication started with "modules".

In the event of enquiries dealing with typical problems encountered by a number of developing nations, but for which no suitable solution is available or can be obtained, GATE has the opportunity to suggest appropriate R & D measures to various sources of finance.

AN IMPORTANT NOTE TO THE READER OF OUR INFORMATION MODULES

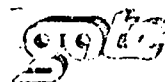

WITH THE MODULES EDITED WITHIN THE QUESTION-AND-ANSWER-SERVICE WE AIM TO GIVE AND COMPILE INFORMATION ON VILLAGE-LEVEL-TECHNOLOGY. WE TRY TO STIMULATE THE DEVELOPMENT OF MAINLY RURAL AREAS WITH A STRONG EMPHASIS ON THE SELF-HELP CONCEPT.

BY NO MEANS DO WE INTEND TO PRESENT A SORT OF RECIPE FOR AN APPROPRIATE WAY OF DEVELOPMENT OR FINAL TECHNICAL SOLUTIONS WHICH WE CONSIDER TO BE THE ANSWER TO THE PROBLEMS CONCERNING THE QUESTION OF DEVELOPMENT IN RURAL OR SUBURBAN AREAS.

KNOWING WELL THAT INFORMATION IS THE FIRST STEP WHEN CHOOSING ACTIVITIES AND THAT - ESPECIALLY IN THE FIELD OF TECHNOLOGY - THERE IS A GREAT AMOUNT OF INFORMATION AVAILABLE, WE TRIED TO SELECT SOME OF THE SPECIFIC TECHNOLOGY NEEDS OF THE MAJORITY OF PEOPLE IN DEVELOPING COUNTRIES. THESE PEOPLE LIVE IN AREAS WITH A LACK OF WATER SUPPLY, SANITATION FACILITIES, APPROPRIATE HOUSING POSSIBILITIES, WHERE GENERALLY THE FOOD PRODUCTION IS LOW AND INEFFICIENT, THE ENERGY DEMAND IS NOT AT ALL MET AND THE MAJORITY OF PEOPLE IS ONLY PARTLY OR NOT AT ALL EMPLOYED.

THE SELECTION OF TOPICS WITHIN OUR INFORMATION SERVICE NORMALLY IS THE RESULT OF AN EVALUATION OF INQUIRY-STATISTICS, I.E. AFTER HAVING RECEIVED SEVERAL QUESTIONS IN THE FIELD OF SOLAR COOKER, FOR INSTANCE, WE DECIDED TO COMPILE THE INFORMATION CONCERNING THIS TOPIC AND EDITED THE "SURVEY OF SOLAR COOKERS".

THUS, THE FEEDBACK WE GET FROM INSTITUTIONS AND INDIVIDUALS IN THE THIRD WORLD PLAYS AN IMPORTANT RÔLE FOR THE QUALITY OF OUR MODULES AND THEIR ORIENTATION TO PRACTICAL WORK. THEREFORE WE ASK YOU NOT JUST TO READ OUR INFORMATION BUT TO WRITE BACK TO US AND TELL US YOUR OPINION AND CRITICISM.

THIS IS THE BEST WAY FOR US TO CHECK THE QUALITY AND EFFICIENCY OF OUR QUESTION-AND-ANSWER-SERVICE. AND FOR YOU IT COULD BE OF HELP, TOO, BECAUSE WE MIGHT SUPPLY YOU WITH MORE DETAILED INFORMATION WHEN WE KNOW MORE ABOUT THE SITUATION YOU ARE IN AND TAKE INTO CONSIDERATION YOUR SPECIFIC PROBLEMS.

IN ADDITION, THE EXPERIENCE YOU HAVE GAINED AND INFORMED US ABOUT, MIGHT BE USEFUL FOR OTHERS. HAVING CONTACTS WITH MANY ORGANISATIONS IN DIFFERENT PARTS OF THE WORLD WE ARE IN A POSITION TO FORWARD YOUR IDEAS AND PROPOSALS IN THE FIELD OF TECHNOLOGY TRANSFER AND APPROPRIATE TECHNOLOGY.

PLEASE FILL IN THE QUESTIONNAIRE (NEXT PAGE) TO ENCOURAGE OUR EXCHANGE ACTIVITIES FOR OUR MUTUAL BENEFIT.

GATE
C/O DEUTSCHE GESELLSCHAFT FÜR
TECHNISCHE ZUSAMMENARBEIT
(GTZ), GMBH
POSTFACH 5180

D-6236 ESCHBORN 1

FEDERAL REPUBLIC OF GERMANY

Please fill in this questionnaire
and send it to

Your name and address:

GATE c/o
Deutsche Gesellschaft für
Technische Zusammenarbeit, GmbH
P.O. Box 51 80
D-6236 E s c h, b o r n 1

QUESTIONNAIRE

MODULE No. _____

DATE _____

1. How did you get this information?

- I requested it from GATE
- Someone else gave it to me (Who was it? _____)
- or:

2. Did you read the complete module?

- yes, from the beginning to the end
- only in parts
- only the parts I was specially interested in
- or:

3. What is your opinion of it?

- a) general understandig
 - difficult
 - just right
 - easy
- b) theory and basic knowledge
 - too much
 - just right
 - to little
- c) orientation to practical work
 - lacking
 - limited
 - just right
- d) language, over-all presentation
 - appropriate for your needs
 - too complicated
- d) what else do you think is worth mentioning?

(Please use the back of this page for additional remarks and suggestions!)

4. Do you see any practical application for the received information?

TABLE OF CONTENTS

Preface	
1.	Definition of Small - Scale Irrigation 1
2.	Socio - Economic Situation 4
1.	Comparison Rain-fed and Irrigated Farming 4
2.	The Social and Economic Status of the Smallholders 5
3.	Rights of Water and Ground 6
4.	The Institutional Framework 7
5.	EXAMPLE : Rural India 8
3.	Planning and Completion 9
4.	The Natural Situation11
1.	Ecological Balance11
2.	Topography12
3.	Climate13
4.	Hydrology14
5.	Water Quality16
6.	The Soil17
5.	Crop Water Requirements23
1.	Crops and Water23
2.	Soil and Water26
3.	Irrigation Requirements30
4.	EXAMPLE: Calculating Irrigation Requirements30
6.	Technical Lay-Out of the Irrigation Scheme33
1.	General Comments on the Irrigation Scheme.....33
2.	Water Source35
3.	Channels36
1.	Alignments37
2.	Dimensions38
3.	Channel-Lining39
4.	Earthen Channels39

4.	Surface Irrigation Methods43
1.	Basin Irrigation45
2.	Border Irrigation49
3.	Furrow Irrigation49
4.	Corrugation Irrigation53
5.	Wild Flooding56
6.	Efficiency57
7.	Special Irrigation Methods59
5.	Drainage63
1.	Soil Drainage63
2.	Drainage Channels63
3.	Designing Drainage Systems64
7.	Operation of the Scheme66
1.	The Technical Aspects of Operation66
2.	The Organisation of Operation70
3.	Maintenance73
4.	Miscellaneous73
5.	EXAMPLE: Fair Distribution in Bali75
8.	The Financial Aspect76
1.	Costs76
2.	Yields78
3.	Financing79
4.	The Role of Co-operatives and Government79
	Recommended Literature81
	Appendices82

PREFACE

Small-scale irrigation as an area of investigation and interest often goes unnoticed, either because individual situations vary so greatly or because the difficulties of assisting such farmers seem insurmountable. This booklet should serve as an introduction to small-scale irrigation and offer a base on which to build a constructive dialog about it's problems and possibilities.

Small-scale irrigation as an appropriate technology is practiced in very concrete situations. We offer no concrete instructions, but prefer to explain basic principles and techniques. Special emphasis is put on the influence of the social, economic, and political environment which gives every technology it's significance.

This booklet proceeds in much the same way as the planning of an irrigation scheme will. We first discuss the basic requirements for small-scale irrigation schemes. (Chapter 1) The general socio-economic situation of most smallholders in the third world is then outlined. (Chapter 2) We then move to the specific local conditions that must be considered before construction begins, such as climate, topography, and soil conditions. (Chapters 4,5) Based on these conditions, we discuss possible lay-outs for differing irrigation schemes. (Chapter 6) The importance of scheme-organistion in securing operation follows. (Chapter 7) Finally, we broach the financial aspects, which are both necessary to the successful building of a scheme and often entail substantial investment. (Chapter 8)

We found the books by BOOHER and STERN especially helpful when writing this booklet. Additional studies which assisted us and which will provide further particular information are found in the literature list appended.

Finally, we are particularly indebted to those who gave their time to talk to us or assisted us in other ways.

1. DEFINITION OF SMALL - SCALE - IRRIGATION

IRRIGATION is the process which supplies water to cultivated plants to secure sufficient moisture during the entire cultivation process (in addition to rainfall).

This definition disregards the social, economic, and political ENVIRONMENT out of which a technique is developed. In the following therefore, we put special emphasis on the relationship between technique (here: irrigation) and society.

SMALL - SCALE - IRRIGATION is comprehended as a technology which corresponds to the abilities and needs of its users, as an APPROPRIATE TECHNOLOGY.

As far as the SIZE is concerned it can be managed by a single farmer with a small hand-pump or by an entire (village) community.

Because the natural (climate, topography) and social (cultural, political) situations are different in different parts of the world the PRINCIPLES can be only defined very generally. Every installation should share the following characteristics:

- Low level of capital costs.
For the construction of the channels and buildings/structures, the levelling etc. should
- make use of local materials.
For example, as little concrete, metal, etc. as possible (cement is expensive and/or difficult to obtain).
- The employment of local skills and labour.
- The schemes are small enough in scale to be affordable and manageable by a small group of farmers.
- It is presumed that the people can and will work together because in most parts of the world decisions are made by groups rather than by individuals.
- The technology must be understandable and comprehensible (causes produce effects). In many cases the establishment of a new irrigation system leads the farmers to new farming conditions. To adopt them the farmer must see their advantages. The importance of every small element for the whole system has to be seen. (For example, the importance of cleaning the canals, if it is not done there will be no water).
- The technology should fit the culture-context of the users (night work, religion, etc).

- The new technology should be based upon the old one. This means that at least a little hydraulic knowledge should be available, and that no new crops with unknown risks will be cultivated in the beginning.
- Dependence on outside help (concerning finances, inputs, technical knowledge) should be kept at a minimum.
- Involve decentralised renewable energies such as wind, sun, animals, and try to avoid (expensive) fuel and electricity.
- The system should be erected step by step so that (possible) mistakes can be eliminated immediately. In this manner the system can be flexibly adapted to ever-changing circumstances.

These considerations have to be understood in a particular local context. The use of heavy machinery, for example, to construct a dam is entirely possible.

Small-scale irrigation as an appropriate technology is accomplished within a very special situation and therefore CANNOT BE TRANSFERRED. Therefore also the examples are given to show the problems and possible solutions, and are not considered the only solutions.

IRRIGATION has been known as long as man has practiced agriculture. Today there are still some 3000-year-old systems working properly. This demonstrates their appropriateness. If one wants to begin irrigating, he should first determine if anyone has irrigated there previously. Perhaps some old irrigation networks exist, even as ruins. From these it is possible to learn about old systems and their problems and it may be possible to improve them with the assistance of new knowledge and methods.

The following example is from Tanzania and shows the enormous impact of irrigation on social and political life.

This cannot be neglected because the INTRODUCTION OF IRRIGATION leads to fundamental changes in social and economic life.

EXAMPLE: The irrigation system in Uchagga, in the Kilimandjaro Region. 1)

Climate (much rain) and fertile soils of volcanic origin lead to intense and productive agriculture (cultivation of coffee, bananas, etc.).

The irrigation system consists of a branching system of channels which lead the water flowing downhill to the fields and settlements. It's age is estimated at three or four hundred years.

The people of Chagga were divided into several clans and held together by a ruling clan. Mutual aid and many special ceremonies were as common and necessary as a well-defined division of labour based on clan patterns, all for the benefit of the chiefdom.

Some members of some clans were irrigation experts who were able to build the channels with astonishing precision and without the help of modern instruments. Because some of these channels extended over some miles, the cooperation of different clans was necessary. Troughs were laid across valleys to conduct the water. Reservoirs were built because only one plot at a time could be supplied by one channel.

The importance of the channels can be seen from the fact that tampering with the given water-rights could lead to clan wars. Sacrifices were offered to secure these rights as well as at the beginning of renovation works.

The users of one channel were organised in an association and were restricted to their assigned irrigation-times or servicing their works, otherwise punishment was threatened.

The description makes evident the enormous impact of irrigation upon the social order (and vice-versa!). It secures the food supply and is directly related to the organisation of the society. Intervention by the colonial powers led to revolts by the people.

The future of the system is unfortunately insecure. The provision of tap-water to villages has led to a deterioration in channel-maintenance. At the same time, higher land-use has begun to dry up the springs. To the present day however, it secures sufficient yields for Chagga farmers.

1) F.T. MASAO, "The Irrigation System in Uchagga." Tanzania Notes and Records, No. 75, Dar Es Salaam, 1974.

2. THE SOCIO - ECONOMIC SITUATION

In this context it is hardly possible to present all the possible constellations of economic, political, social, and agricultural factors. We just describe some basic but important facts.

2.1 Comparison. Rain-fed and Irrigated Farming¹⁾

Irrigation farming has distinct ADVANTAGES compared with rain-fed farming. Because of irrigation, the natural, ample, and regular supply of solar energy is allied firstly with the ample and regular supply of water, and secondly with the nutrients brought by water (mainly by silting). Moreover, irrigation, particularly in the form of impounding, avoids the stress to plant growth that is connected with very high temperatures on the soil surface. In detail:

- 1.) Irrigation farming produces higher gross yields per hectare. The basic possibilities are that:
 - higher yields per hectare of a particular crop may be achieved.
 - several harvests a year may be produced.
 - crops may be grown that produce comparatively high yields per hectare.
 - continuous cultivation of rice becomes possible.
- 2.) Irrigation farming allows permanent land use, without the need for fallowing (time in which soil "recovers").
- 3.) Yield fluctuations from year to year are reduced. The chance of regular household supply of food and/or cash income improves. There is no (at least direct) dependence on the relatively unforeseen occurrence of rainfall.
- 4.) Arable farming is relatively adaptable to the needs of it's users with regard to both type and intensity of production.
- 5.) Irrigation farming allows the productive employment of a relatively large number of workers per hectare. It therefore enables a relatively high income to be earned without the use of expensive equipment. In hoe systems, one family can scarcely cultivate more than 2-3 hectares, which in rain-fed farming permits only a minimal standard of living, but in irrigation farming the same area will allow a high standard of living.

1) H. RUTHENBERG, Farming Systems in the Tropics, Oxford, 1971, p. 139.

- 6.) Irrigation development gives value to land that could not otherwise be utilised, or would be under-utilised (dry land).

However, against these advantages must be set definite COSTS AND REQUIREMENTS:

- 1.) Irrigation farming necessitates a high level of investment in water supply, delivery, distribution works, land preparation, and in several inputs. These costs are comparatively high on every level.
- 2.) It demands a continuous high level of labour input to supply the water and prepare and maintain the fields.
- 3.) It, as a rule, requires the cooperation of the farmers. In large-scale schemes this is very often a reason for mal- or dysfunction.
- 4.) In addition to agricultural knowledge it also requires special technical skills.

The introduction of irrigation leads to changes in the agricultural, social, economic, etc. patterns with CONSEQUENCES which cannot be anticipated. Therefore the development has to be slow and cautious. For some time rain-fed and irrigation farming might be practiced parallel (exploitation of very small rivers) or may alternate (rice in the rainy season, corn in the other time).

2.2 The Social and Economic Status of the Smallholders

The following and more theoretical considerations will be illustrated by an example in section 2.5.

The economic situation of most smallholders in many parts of the less developed countries is characterised by the fact that they either solely produce for their own (i.e. their family's) SUBSISTENCE or that they work dependently on PRIVATE-OWNED ESTATES or as tenants.

The tenure is paid by a certain part of the yield (as much as 50% or more) or paid in cash through directly cultivating the land. This results in the accumulation of a considerable amount of the agricultural income in the hands of a few rich who by this acquire the possibility of further modernising. In many cases they are also the beneficiaries of public agricultural policy. This process leads to a steady worsening situation for the dependent smallholders. It can lead to an inability to cultivate their land and force them to work as LANDLESS labourers for a landlord.

Mounting population pressure as well as the current right of succession leads to increasing divisions of agriculturally profitable land. A large number of

SMALLHOLDER-FARMS are cultivated which rarely are able to satisfactorily support the people. To counteract this process, i.e. to secure the food-supply by intensive agriculture, the introduction of irrigation can be significant.

A smallholder farm of this type is often cultivation of less than one hectare. This area has to provide for an entire family. For this reason a stable income (i.e. security) is more important for the farmer than maximum profit. Moreover, this land represents his pension-scheme. To keep his risk at low levels he will be cautious about new, unknown, and therefore risky inventions. For the farmer this proves to be the most **ECONOMIC** (in many cases also **écologic**) **APPROPRIATE MODE** of behaviour. Changes take place within the framework of the technical knowledge and have to be evident in their success. This "safety margin" will be greater for (large) groups. Within these community groups mutual-aid is very common which facilitates the, frequently occurring with irrigation, need of intensive labour during short periods (harvesting, etc.).

The **FINANCIAL POSSIBILITIES** of a single farm are low because it cannot accumulate capital for innovations but has to spend it for the needs of daily life. It is forced to borrow capital.

For these reasons the fully new introduction of irrigation in areas with no previous experience and mainly subsistence agriculture seems to be less recommendable.

It is necessary to examine the **LOCAL BALANCE OF POWER** (i.e. dependence on the landlord; and, who has authority in the village?) as well as the willingness for cooperation among the users. This is of great importance because without it the project will fail sooner or later. (See Chapter 7.)

One also has to see who is the real **BENEFICIARY** of the introduction of irrigation. Does the necessarily increasing amount of labour lead to increased work, especially for the women? Who is responsible for marketing the products? If this is done by the landlord (he might have the necessary infrastructure) or a merchant having a monopoly, the profit is gained by the wrong people.

2.3 Rights of Water and Ground

Despite the importance of this aspect it is impossible, because of the variety of laws, to examine it in great detail.

The construction of irrigation facilities can be made rather difficult because of **EXISTING RIGHTS** and/or field boundaries. The underlying principles are solely of a **hydraulical** nature. The single fields should not be too

far apart, in order to reduce channel-length. Exchange of fields might become necessary. In cases where the land is cultivated on a tenant-basis, long-term use should be secured. The state might support this by agrarian-reform laws, but this is a rather political theme. (See also section 8.4.)

The right to draw water off streams, rivers, or springs, is very often regulated by special WATER RIGHTS. A certain amount of the actual runoff (down to a minimum discharge) is allowed to be drawn off. These rights protect the interests of other users downstream and have to be obtained from the local authorities.

2.4 The Institutional Framework

If the small scale irrigation facilities are constructed by its users, AUTONOMOUS INSTITUTIONS, like the village council, the cooperative society, or special associations should guarantee its security rather than landlords or private institutions.

Investments are necessary which very often are beyond the FINANCIAL POSSIBILITIES of the users (costs for materials, machinery, omitted working-time, etc.). Credit has to be obtained either from private money-lenders or (state-owned) credit-banks. Both possibilities are often not in favour of the small farmers. In the first case, high interest will have to be paid which leads to the further dependence of the smallholder; in the second case, the farmer might not have enough security to obtain a loan.

For reasons of SOIL FERTILITY or to secure the yield, the use of (artificial) manure and plant-protection sprays might be necessary. If these are not self-produced (for example, mulch) they have to be bought. (= costs!) Sometimes special fertiliser-programmes of the government exist to secure the distribution. In this case, long-term supply must be safe and development of its costs should be estimatable. Not very many countries produce their own fertiliser and usually it has to be purchased with expensive foreign currency.

The question of MARKETING THE PRODUCT is of great importance. This might become a problem if subsistence agriculture has dominated until the introduction of irrigation and the newly produced surplus-yield has to be marketed, but there are no marketing facilities or they are far away. A trade commission might be created which leads to new dependence and/or helps to increase smallholder encumbrance. Productivity then declines and this might lead to even reduced subsistence.

Existing institutions are often private or state-owned and under the control of the rich. In this case the establishment of people's own cooperatives might be advisable.

2.5 Example. Rural India¹⁾

In India half of all farms (42%) cultivate less than one hectare. They represent only 7% of the arable land. Only by the use of irrigation can these plots provide enough food for one family.

The rural upper classes own more land and more capital. Therefore they are able to cultivate cash-crops with high capital-needs for irrigation-works, fertiliser, and labour input. When they market them they get high returns and are able to reinvest and modernise the farms. The smallholders become poorer and migrate to the metropolis or they work for minimum wages on large farms in addition to cultivating their own plots. Thus the problem is of a political and not a technical nature.

Through the actions of the colonial power, Britain, the traditional asiatic mode of production, which contained collectively-owned land, was destroyed and individual ownership of land was introduced.

The independent government tried to improve the situation of the poor peasants through agrarian reform but failed due to the influence of landlords, money-lenders, and merchants who controlled the administration. In addition the distribution of government aid designed for the poor, only occasionally reaches them.

1.) J.M. MELLOR, et.al., Developing Rural India, Bombay, 1972; and other sources.

3. PLANNING AND COMPLETION

We assume that there is a group of potential users who consider the introduction of (additional) irrigation for their existing agriculture. All of them should be in about the same economic situation.

Precise and extensive PLANNING is necessary because of the high initial costs connected with irrigation. On the basis of the described relationships, the local situation must be examined. During the entire planning and completion stage, full USER-PARTICIPATION should be insured. This is essential because for each farmer his land is the foundation of his family's existence.

As far as possible locally existing skills, (agricultural) practices, institutions, etc. should be taken over and/or further developed. DEVELOPMENT has to proceed step by step and remain flexible. In this manner risks and financial burdens are minimised. One can start from the principle that the traditional situation is a balance between ecological, economic, social, political, technical, and agricultural circumstances. This balance should not be disturbed; therefore at all times there has to be the possibility of CORRECTING the process.

With the help of EXPERIMENTS on a small part of the area, experience can be gained.

The following items should be considered before beginning construction:

- What local skills and needs exist?
Irrigation should only be introduced when there is a real need. It should be based primarily on local labour.
- Is irrigation technically feasible? (See the following chapters.)
- Which crops are cultivated, and how?
At least in the beginning these should not be altered.
- Is the project financially feasible and is it worthwhile? (i.e. are the returns higher than the costs?)
- What institutions exist or need to be created?
The association which will be responsible for the operation should be put into action during the construction phase. Must a cooperative be founded?
Is there sufficient communal labour or must outside labour be hired?
- Will the input-supply also be secured in the future? (water, seed, fertiliser, energy, etc.)

After having answered these points the technical planning and construction must be done. Parallel to this, the organisational structure has to be erected as well as the possibly necessary infrastructure (store, roads, etc.). The experimental plot should be situated in a way that it can be easily included in the entire project. Construction works should be carried out uninterrupted and be completed in time for the first seeding period.

4. THE NATURAL SITUATION

4.1 Ecological Balance

Under the influence of the different environmental factors in each region of the world a characteristic vegetation-typus evolved. The plants have OPTIMALLY ADAPTED to their natural environment. In a similar way in each region different agricultural techniques are found. Traditional agriculture has adapted to it's surroundings in such a way that it can neither be destroyed by inclement weather nor itself destroy the environment, it's base of existence.

Preservations of the natural balance is the main task of any technological interference, such as irrigation.

EXAMPLE. The Destruction of the Natural Balance.

For several hundred years irrigated farming has been practiced in different oases in the Sahara. The pumped water supply is in balance with the ground-water replenishment. One reason for this was the simple fact that only limited pulling power (men or animals) was available. This, on the other hand, was related to the irrigated area.

Through the installation of diesel pumps it became possible to extend the irrigated area due to higher water supply. After only a few years however, the water table fell to a depth where further ground-water pumping became uneconomical, and the water yield lessened. Agricultural areas were devastated, erosion destroyed the soil, and ground-water replenishment declined. Today only desert is found at these places.

Before starting to plan the lay-out, etc., the natural situation has to be examined.

This brings about:

- a statement about the aptitude for irrigation.
- optimal adaptation of the system.

When CHARACTERISING the intended site for irrigation, it is necessary to describe:

- topography
- climate
- hydrology
- soil
- vegetation (natural and artificial)

4.2 Topography

By topography is meant the form and shape of the land. Topographic maps using a large scale have to be available or drawn. (For a guide to simple surveying and mapping, see Appendix A .)

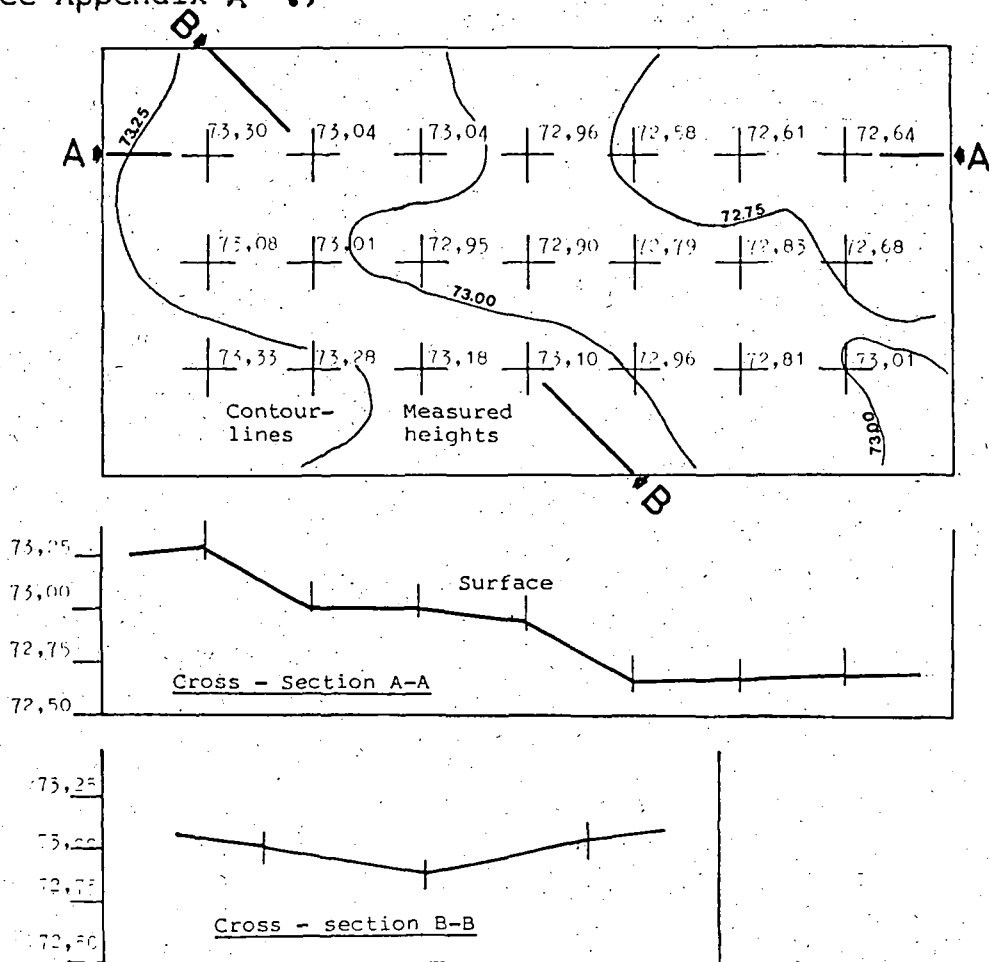

Making a map with contour-lines out of measured heights as well as drawing cross-sections of the area.

Obtaining this information enables a first assessment of the area:

- Differences in elevation:
 - Is water supply possible from the high (est) elevation?
 - Is the supply possible down to the lowest point?
 - Are water-lifting devices necessary, and with what difference in elevation?
- Maximum/minimum gradient.
 - Is there danger of erosion?
- Unevenness.
 - Is land-levelling necessary?
 - What size of fields is possible without levelling?

◆ The best suited is uniformly level land.

4.3 Climate

The climate determines which plants can grow as well as their water-requirements. Irrigation is needed when natural precipitation is not sufficient. Information should be as precise as possible, the most useful data being:

- Rainfall.
 - amount (mm/year)
 - distribution (mm/day)
 - intensity (mm/hour)
 - frequency
- Temperature: (degrees Centigrade)
 - mean monthly temperature $(\text{Max. T} - \text{Min. T}) / 2$
 - extremes
- Evaporation (mm/year, month or day)

On earth three main types of climate are known:

- arid. The theoretical evaporation is higher than rainfall.
- semi-arid. The theoretical evaporation is mostly higher than rainfall.
- humid. Less evaporation than rainfall.

For each area of the world a climate-diagram can be drawn:

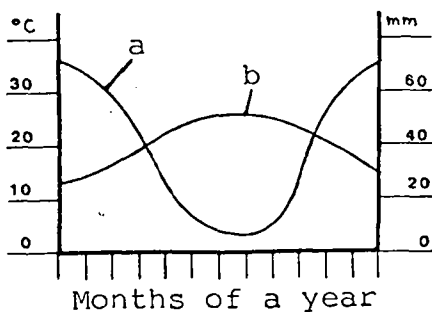

- a) Rainfall
- b) Mean monthly temperature

Due to the small scale, an extensive data collection is not normally possible because it takes a long time and is expensive. In addition, it is often not necessary because with a relatively high degree of flexibility, possibly wrong estimates can be rather easily corrected.

◆ Data may be obtained at:

- Hydrological computing centres
- Estates, etc.
- Administrative authorities
- Airports, harbours, etc.

Additional measurements should be made during construction and operation:

- Rainfall - rain gauges
- Temperature - thermometer
- Evaporation - evaporation pan
- Humidity - wet and dry bulb thermometers

4.4 Hydrology

The available water supply can be calculated with the aid of hydrological measurements and computation, but this is too far-reaching for our purposes.

The hydrological SITUATION of a limited area can be described with this FORMULA:

$$A = Z + N - E - V$$

where: A = surface run-off

Z = tributaries of streams, rivers, etc.

N = rainfall

E = evaporation

V = deep percolation

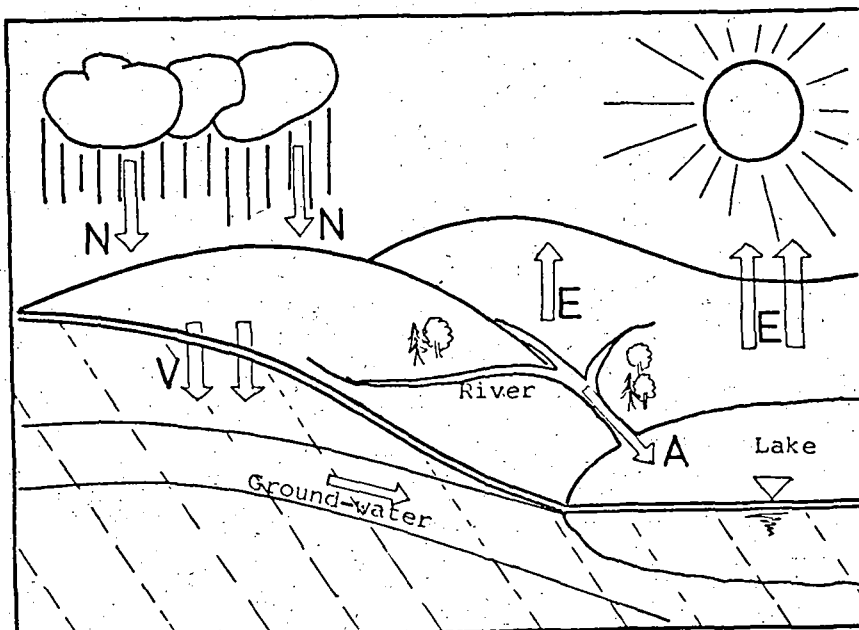

HYDROLOGICAL CYCLE under humid conditions

The hydrological cycle describes the movement of water from the atmosphere to the earth's surface and back to the atmosphere.

- ▶ Irrigation water is taken from surface run-off or ground-water.
- ▶ Surface run-off is mainly dependent on rainfall, and can be quite unsteady.

--Intake from surface run-off--

Because the irrigation-water is taken from natural WATER-COURSES like rivers, creeks, springs, etc., it's amount and distribution throughout the year should be well-known, to safeguard the supply. Long-year observations are therefore helpful.

- ▶ The population can possibly give some information about this, and especially about the extremes, which are important to know.

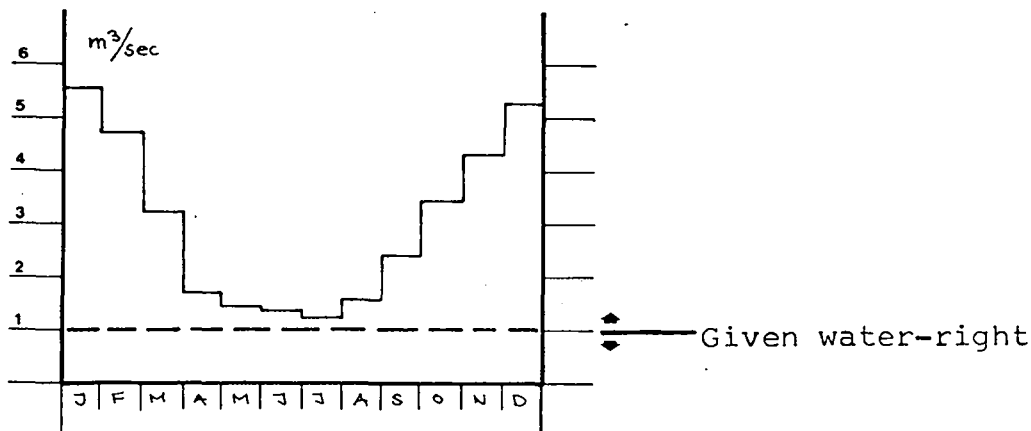

Discharge curve of a river,
given in m^3/sec , over one year

If the small-scale scheme supplied through a channel belongs to a large-scale scheme, the question of water-rights and especially long-term granted supply, is important.

If the water is taken from LAKES, a careful examination of the water-quality is necessary because of the dangers of salinity and infections. Normally, water-lifting devices will have to be installed when taking the water from lakes.

--Groundwater-yield--

It is very difficult to estimate the groundwater situation of a region. A large number of testing-wells are necessary. Sometimes the position of (existing) wells allows conclusions about the aquifer. Wells are sunk into the lowest stage of the water table.

Sufficient groundwater replenishment is obtained when the water table does not fall beneath this level during irrigation. In no case (further sinking) should the lowest stage threaten deep-rooting plants, like trees.

When constructing several wells at the same time, a distinct minimum of interval has to be observed to avoid interference.

The capacity of a well is more often limited by the capacity of the necessary water-lifting devices (energy-consumption) than by the capacity of the well.

4.5 Water Quality

For the purpose of irrigation, the water used must be examined. All natural waters contain some impurities.

-Physical properties:

Impurities such as sediment and silt in suspension are not harmful and may help to maintain the fertility of the soil. Sedimentation in the channels can help to prevent seepage, but it can also lead to deterioration of the hydraulic properties. In the field it can lead to scour. (This can be prevented by tillage.)

-Chemical properties:

The determination of the quantity of salt in the irrigation water must be determined, as well as the type of the salts. This is indicated by electric conductivity, measurable in the field, and expressed in micromhos.

The actual concentration of salts which is harmful depends very much on the chemical characteristics of the soil and on the type of crops being grown. Salt containing water hinders plant-growth and therefore leads to decreasing yields. Sometimes this can be prevented by leaching the salts with a higher irrigating head.

Too high a concentration of salts, however, is toxic for the plants and destroys the soil structure.

<u>STANDARDS FOR IRRIGATION WATER</u>				
Quality of water	Crops Suited	Conductivity Microhos/cm	TDS mg/l	Boron ppm
good	all crops	50-500	0-600	0-0.5
moderate	injurious to sensitive crops	500-2200	600-2000	0.5-2.0
poor to unsuitable	harmful to most crops	over 2200	over 2000	over 2.0

TDS = total dissolved solids. Source: /9/

Exact determination of type and concentration of the different salts (Boron, Chlorides, Sulphates, Sodium) is essential and complicated. It should be carried out in a laboratory.

▶ A salt concentration of about 2000 micromhos is often tasted with the tongue. This is a very inaccurate method.

4.6 The Soil

Small-scale irrigation should, in the beginning, only be used on land previously used for agriculture. Therefore the soil is potentially fertile. The soil properties have to be known to determine the best irrigation-method and application.

-- Soil Formation--

Soil material is formed from the breaking-down of rock into small particles by a process known as weathering. This occurs under the influence of rain, (snow), air, wind, temperature change, and the chemical action of slightly acid water.

Agricultural soils are described by their origin, their colour, and their texture. COLLUVIAL SOILS are formed from material washed down by rainwater, but not transported by streams and rivers. Soils formed from material carried and deposited by streams and rivers are known as ALLUVIAL SOILS. VERTISOLS are soils which are formed over their present rocks without lateral particle movement. The colours of the soils vary from almost black through shades of red and brown to light yellow. Colluvial and alluvial soils are often quite fertile.

There exist many other classification systems.

Soils are deposited in horizontal layers. These horizons must be carefully examined. The examination depth should be as deep as possible (at least 2 meters) to identify eventual rock or gravel levels as well as the aquifer. This is necessary for subsoil drainage.

-- Composition of the Soil --

A fertile soil contains two distinct solid components: mineral matter (as described above), and organic matter (humus). Pores are partly filled with water and make the circulation of air possible.

Optimum: -50% hard matter.
(organic/mineral = 1 / 10)
-50% pores, half filled with water.

- ▶ Organic matter improves the fertility and loosens the soil.
- ▶ The darker the soil, the more organic matter it contains.

-- Texture --

Movement of water in the soil is a function of its texture and structure. This determines the aptitude for irrigation.

The texture depends upon the relative proportions of different-sized particles in their make-up. The proportions can be determined by mechanical analysis. It is also possible to apply a field method. (See Appendix C). These mineral components can be classified according to the particle size as follows:

Name	Size Limits (Particle diameters)
gravel	above 2 mm
coarse sand	2.0 - 0.2 mm
fine sand	0.2 - 0.02 mm
silt	0.02 - 0.002 mm
clay	less than 0.002 mm

The textual descriptions follow the dominant particle sizes in their make-up, so that soils are described as sand, loam, silt, clay, or combinations of these. The term loam indicates a well-graded component in which no one particle dominates. The differences between these types are not rigid but the following may be used as a general guide:

- sandy soils - 60% or more of sands.
- ▶ loams - Some sand or not more than 30% clay.
- clay soils - Over 30% clay and less than 50% sand.

The terms 'light' and 'heavy' refer to the amount of power required to draw a cultivating implement through the soil. In this context, sandy soils tend to be light, loams medium, and clays heavy.

The STRUCTURE describes the relative positions of the particles to each other; and their shape.

A favourable soil (structure) can be made worse by non-appropriate irrigation (silting-up, etc.). The danger of erosion rises, and the movement of water decreases. On the other hand, it can be improved through tillage, etc..

The soil development should be examined from time to time.

-- Infiltration --

Infiltration is the process by which water enters the soil by gravity. The rate of entry is measured by the infiltration rate which is expressed in millimeters depth of water per hour. It is different for different soils, and also depends on the actual moisture content (dry soil and high infiltration rate).

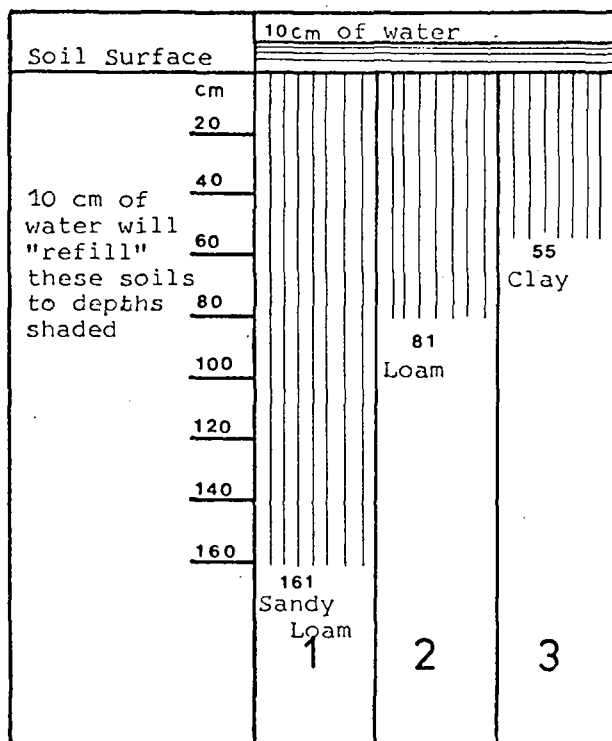

Depth of penetration of water in various soils from a 100-mm irrigation.

Source: THORNE/PETERSON,
"Irrigated Soils",
New York/Toronto, 1954

The irrigation-application rate should be the same as the infiltration rate (see the following chapters, example in 7).

<u>SOIL INFILTRATION RATES (mm/h)</u>	
<u>Soil</u>	<u>Infiltration Rate</u>
clay	1 - 5
clay-loam	5 - 10
silt-loam	10 - 20
sandy loam	20 - 30
sand	30 - 100

If the application rate is higher than the infiltration rate, water will be wasted; if it is lower, evaporation losses may be unnecessarily high.

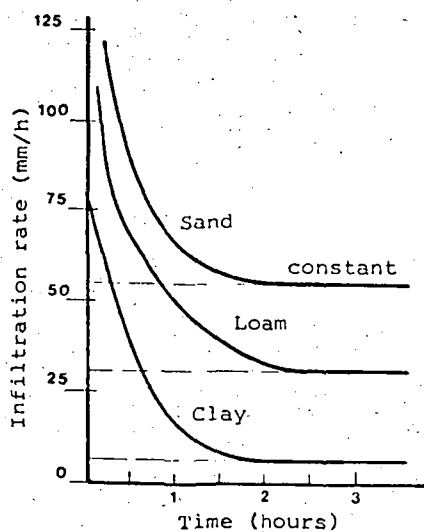

Typical Infiltration rates,
decreasing with time

-- Salinity --

Each irrigation raises the DANGER OF SALINISATION. Small amounts of salt can be found in every particle of water. Under arid conditions, with a high evaporation rate, the salt concentration will be especially high.

This also leads to a higher concentration in the ground water. If the ground-water-table lies near the surface

the water rises due to capillarity, evaporates, and leaves the salt in the surface layers of the soil. Especially heavy excess-irrigation leads to a raising of the ground-water-table, accelerating the process..

Excess of the chlorides and sulphates of sodium, potassium, magnesium, and calcium, form a white crust at the soil surface, often known as white alkali.

Sodium carbonate, sometimes associated with potassium carbonate, produces black alkali soils forming sodium hydroxide which dissolves organic matter causing a dark-coloured crust at the soil surface. These salts are harmful to plant roots, damage the structure, and may reduce the availability of plant nutrients.

RELATIVE TOLERANCE OF CROPS TO SALINITY

High Tolerance	Medium Tolerance	Low Tolerance
barley	alfalfa	citrus
cotton	cantaloup	clovers
date palm	figs	field beans
grasses	grapes	green beans
rape	maize	soft fruits
spinach	oats	
	olives	
	peppers	
	potatoes	
	rice	
	rye	
	sorghum, wheat, vegetables	

Saline soils can only be improved through expensive measures (artificial drainage, leaching, etc.).

The danger of salination can be reduced in months with heavy rainfall (monsoon), which LEACHES THE SALTS from the surface through the subsoil.

In case the natural rainfall is not sufficient, special leaching-irrigation should be done after harvesting. (This is better than steady over-irrigation.)

-- Nutrients --

Mineral and organic matter contains several nutrients which are needed by the plant. Under natural conditions these are extracted during growth and are recycled after the death of the plant. Because intense agriculture interrupts this process, nutrients have to be re-supplied through manuring (natural or artificial) to maintain fertility. The most important nutrients are nitrogen, phosphorus and potassium.

Other important factors are acidity and alkalinity.

All these factors are difficult to determine without a laboratory, but they must be considered very important, especially the salinity problem.

5. CROP WATER REQUIREMENTS

Computation of the cultivated crop water requirements as well as of the moisture holding capacity of the soil is important and determines the irrigable area:

$\frac{\text{Actual water supply (l / sec)}}{\text{Irrigation requirements (l / sec} \cdot \text{ha)}}$ given in hectares.

5.1 Crops and Water

Plants need soil, sunlight, air, and water to enable them to live and grow. Water fulfils these primary functions:

- It keeps plants erect by filling the cells which make up plant tissue.
- It acts as a cooling agent during evaporation from the leaves, preventing overheating under hot conditions.
- It carries nutrients in solution from the soil into the plant through the roots.

▶ To build one kilogram dry plant matter, there are 500 litres of water needed (on the average)!

-- Evapotranspiration --

EVAPORATION is the process by which water, in the form of water vapour, enters the atmosphere from open water surfaces or from wet land surfaces. TRANSPIRATION is the evaporation which takes place at the surface of plant leaves (described above). EVAPOTRANSPIRATION (ET; mm) is the sum of:

- transpiration from the plants, and
- evaporation from damp soil and from any open water that may be present in furrows or other depressions.

Evapotranspiration varies with the climatic conditions:

- high evapotranspiration: hot, dry, wind
- low evapotranspiration: cool, humid, no wind

The evaporation share is highest in the initial stage of plant growth. With the development of the leaves the transpiration share rises, while the evaporation share drops due to the overshadowing of the soil.

(See the figure on the following page)

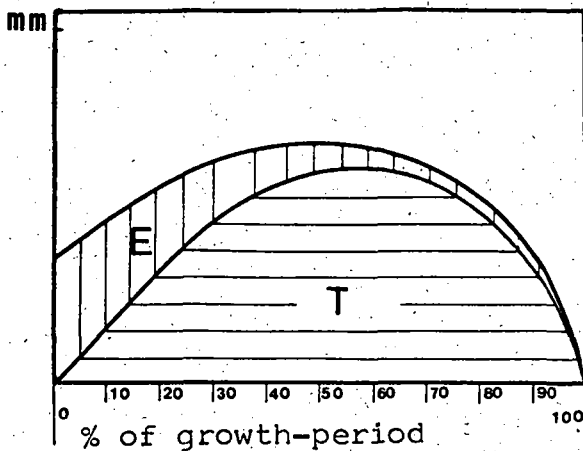

EVAPOTRANSPIRATION of a plant over the growth-period
E = Evaporation-portion; T = Transpiration-portion

Potential evapotranspiration (pET) describes the evapotranspiration which could occur if water were freely available to the plants.

Evapotranspiration is expressed in depth of water (mm) and can be estimated from measured climatic data (it is also possible to measure it directly).

Approximate evapotranspiration figures are:

- ▶ 1 - 3 mm in moderate climates
- ▶ 5 - 8 mm in the humid tropics
- ▶ 10 - 12 mm in very arid climates

Source:/9/

Crop-evapotranspiration (ET_{cr}) is obtained by combining the crop coefficient (k_c) with the reference crop evapotranspiration (ET_o).

-- Potential Evapotranspiration --

The reference evapotranspiration is either measured, for example with an evaporation pan, or is computed by using a formula. We will describe the

BLANEY-CRIDDLE-FORMULA

which is quite easy to use.

$$ET_o = p \cdot \frac{45.7 \cdot t + 814}{100}$$

- where:
- ET_o = potential evapotranspiration (mm/month)
 - p = mean monthly percentage of annual daytime hours (%)
 - t = mean monthly temperature (°C)

The Mean Monthly percentage (p) of annual daytime hours for different latitudes.

Latitude	North	Jan	Feb	Mar	Apr	May	June	July	Aug	Sept	Oct	Nov	Dec
	South	July	Aug	Sept	Oct	Nov	Dec	Jan	Feb	Mar	Apr	May	June
60°		4.5	6.0	7.8	9.6	11.4	12.3	12.0	10.2	8.4	6.6	5.1	3.9
55°		5.3	6.8	7.8	9.5	10.8	11.6	11.3	9.9	8.4	6.9	5.7	5.1
50°		5.7	6.9	8.1	9.3	10.2	10.8	10.5	9.6	8.4	7.2	6.0	5.4
45°		6.2	7.2	8.1	9.0	9.9	10.5	10.2	9.3	8.4	7.5	6.6	6.0
40°		6.6	7.2	8.2	9.0	9.6	10.2	9.9	9.3	8.4	7.5	6.6	6.3
35°		6.9	7.5	8.1	8.7	9.3	9.6	9.6	9.0	8.4	7.5	6.9	6.6
30°		7.2	7.5	8.1	8.7	9.3	9.6	9.6	9.0	8.4	7.8	7.2	6.9
25°		7.2	7.8	8.1	8.7	9.0	9.3	9.3	8.7	8.4	7.8	7.5	7.2
20°		7.5	7.8	8.1	8.4	8.7	9.0	9.0	8.7	8.4	7.8	7.5	7.5
15°		7.8	7.8	8.1	8.4	8.7	8.7	8.7	8.4	8.4	8.1	7.8	7.5
10°		7.8	8.1	8.1	8.4	8.4	8.7	8.7	8.4	8.4	8.1	7.8	7.8
5°		8.1	8.1	8.1	8.4	8.4	8.4	8.4	8.4	8.4	8.1	8.1	8.1
0°		8.1	8.1	8.1	8.1	8.1	8.1	8.1	8.1	8.1	8.1	8.1	8.1

Source:/2-24/

-- Crop Coefficients --

The obtained ETo has to be multiplied by the crop coefficient kc to obtain the crop water requirement.

$$ET_{cr} = kc \cdot ETo$$

This is the actual amount of water used by a crop. kc varies with the crop's growth stage and is different for every crop. (see figure and table)

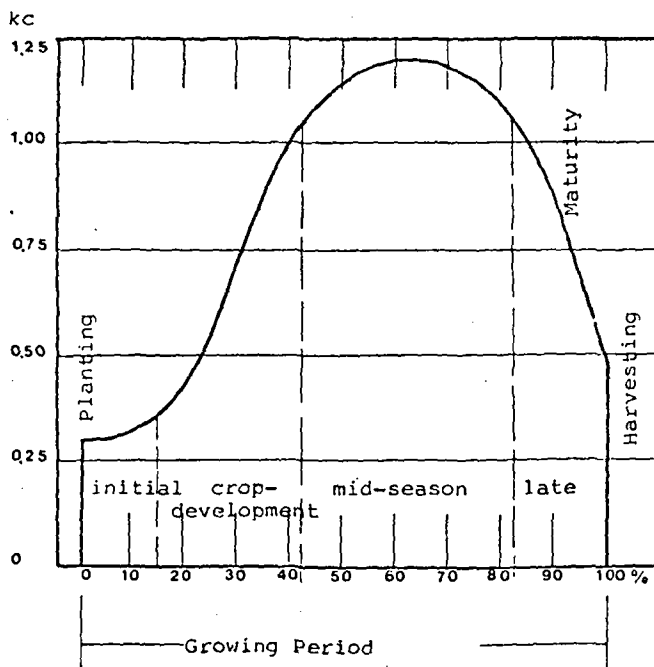

<u>CROP COEFFICIENTS (Kc) FOR VARIOUS CROPS AND THEIR GROWING PERIODS</u>					
Crop	Relative Humidity more than 70% (humid)		Relative Humidity less than 20% (arid)		Growing Period Days
	Mid- Season	Final Growth	Mid- Season	Final Growth	
Barley, wheat	1.1	0.25	1.2	0.2	120-165
Green Beans	0.95	0.85	1.0	0.9	75- 90
Maize	1.1	0.55	1.2	0.6	80-100
Millet	1.05	0.3	1.15	0.25	105-140
Sorghum	1.05	0.5	1.15	0.55	120-130
Cotton	1.1	0.65	1.2	0.65	180-195
Tomatoes	1.1	0.6	1.2	0.65	135-180
Cabbage Cauliflower}	1.0	0.85	1.1	0.95	80- 95
Onions	0.95	0.95	1.00	1.05	150-210
Peas	1.0	1.05	1.1	1.15	90-100
Potatoes	0.9	1.10	0.95	1.2	105-145

Source:/9/

-- Effective Rainfall --

Not all of the rainfall can be used by the plant, and it is therefore necessary to take this into account in the calculations. Measured rainfall N (mm/month) is reduced to effective rainfall N_{eff} (mm/month) in the following way:

Monthly rainfall (mm)	Effective rainfall (mm)
25	24
50	48
75	71
100	94
125	110
150	122
175	128
>200	130

(USBR- Standard)

5.2 Soil and Water-- Moisture holding capacity --

The soil has the capability to store the water in its pores for a certain time and to keep it by this method available to the plants. This moisture holding capacity differs from soil to soil.

The maximum amount of storable water or its SATURATION CAPACITY depends on the volume of its pore spaces. It is expressed in mm/m.

In 1 (sand) to 4 (clay) day's time the GRAVITY WATER will percolate to the ground-water. During this time it is available to the plants.

The remaining CAPILLARY WATER is kept in the soil against gravity. The amount of water retained by soil after gravity water has drained out is known as the FIELD CAPACITY (FK; mm/m).

When plants are short of water they begin to wilt or droop. The term PERMANENT WILTING POINT (PWP; mm/m) defines the level of moisture content in the soil when plants cannot extract the remaining water, and they do not recover with additional water.

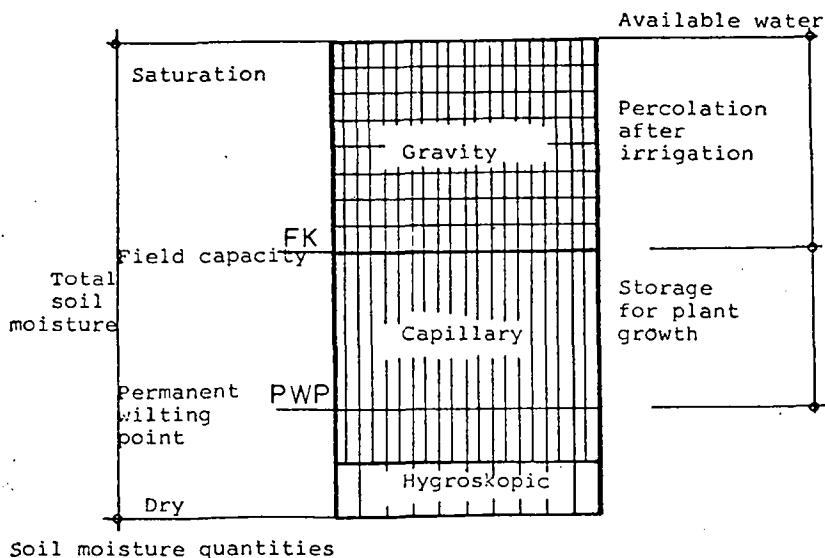

The difference between permanent wilting point and field capacity is known as readily AVAILABLE SOIL MOISTURE CONTENT (nk).

$$nk = FK - PWP \quad (\text{mm/m})$$

This can also be expressed in percent of volume.

<u>RANGE OF READILY AVAILABLE SOIL MOISTURE FOR DIFFERENT SOIL TYPES</u>			
Soil Type	Percent of Moisture based on dry weight of soil		Depth of available water per unit depth of soil (centimetres per metre)
	Field Capacity	Permanent Wilting percentage	
Fine sand.....	3 - 5	1 - 3	2 - 4
Sandy loam.....	5 - 15	3 - 8	4 - 11
Silt loam.....	12 - 18	6 - 10	6 - 13
Clay loam.....	15 - 30	7 - 16	10 - 18
Clay.....	25 - 40	12 - 20	16 - 30

Source: /1/

➔ This indicates that light soils need many light irrigation heads, heavy soils high irrigation heads with long intervals.

➔ Soil moisture content can be measured by complicated means, but also with a relatively easy finger probe, which requires at least some experience.
(See appendix D)

-- Plant, Soil, and Water --

The plant-available water should not fully be used, i.e. the permanent wilting point should not be reached. There are two reasons:

- with decreased water content it becomes more difficult for the plant to extract water.
- most of the water is taken from the upper half of the root zone. Because of this only half of the water is actually used.

The water extracted and used by the plant is taken from it's root zone.

TYPICAL ROOT-ZONE DEPTHS
Depths in metres at full growth

<u>Shallow</u>		<u>Medium</u>		<u>Deep</u>	
Beans	0.3-0.6	Barley	1.0-1.5	Alfalfa	1.0-2.0
Broccoli	0.4-0.6	Carrots	0.5-1.0	Cotton	1.0-1.7
Cabbage	0.4-0.5	Clover	0.6-0.9	Deciduous	
Cauliflower	0.3-0.6			orchards	1.0-2.0
Grass		Eggplant	0.9-1.2	Maize	1.0-2.0
pasture	0.4-0.6	Grains		Sorghum	1.0-2.0
Lettuce	0.3-0.5	(small)	0.9-1.5	Sugar	
Onions	0.3-0.5	Peas	0.6-1.0	Cane	1.0-2.0
Potatoes	0.4-0.6	Peppers	0.5-1.0		
Rice	0.5-0.7	Sweet			
Spinach	0.3-0.5	potatoes	1.0-1.5		
		Tomatoes	0.7-1.5		
		Water			
		melons	1.0-1.5		

Source:/2-24/

► Irrigation will have to fill the empty pores in the root zone.

It should be applied when the soil moisture content is at about 50% of the readily available water content (nK).

It's height should be just enough to fill the pores up to field capacity.

The plants do not extract water in the same amounts from the entire root zone, the content decreases with the depth.

MOISTURE EXTRACTION PATTERN IN PLANT ROOT ZONES

Root Zone Depth	Percentage of Available Water Used	
First quarter	80%	} Average 50 %
Second quarter	60%	
Third quarter	40%	
Fourth quarter	20%	

These relationships will be explained by an example in 5.4.

5.3 Irrigation Requirements

From the plant water requirements (ETcr) and the effective rainfall (Neff) in a certain time, the net irrigation requirements (In) can be computed:

$$In = ETcr - Neff \quad (\text{mm})$$

This is the amount of water needed to supply the plant with sufficient moisture. As the water travels from the beginning of the field to the plant roots, water-losses will occur. To account for this, a field-application-efficiency (Ea) is estimated (see Chapter 6.4.6., page 57).

The field water requirement (If) will then be:

$$In = \frac{ETcr - Neff}{Ea}$$

5.4 EXAMPLE. Calculating Crop Water Requirements

The location is a village at 22° northern latitude. The crop grown shall be COTTON in furrows and basin fields. The water is taken from a river.

The climate data given is:

- mean monthly temperature (t)
- monthly rainfall (N)

For calculating the evapotranspiration we use the formula of BLANEY-CRIDDLE (see page 24); crop coefficients kc are taken from source 2-24, (see also page 26). Rainfall N is reduced to effective rainfall Neff by using the table on page 26.

CALCULATION:

Month	JUNE	JULY	AUGUST	SEPTEMBER	OCTOBER	NOVEMBER
t (°C)	32,1	27,1	26,4	27,0	25,8	21,9
p (%)	9,0	9,3	9,0	8,4	8,1	7,5
ETo (mm)	205	190	181	172	160	136
kc (-)	0,6	0,8	1,05	1,1	1,02	0,65
ETcr(mm)	123	152	183	189	163	88
N (mm)	152	333	304	261	36	15
Neff(mm)	122	130	130	130	33	15
In (mm)	--	22	53	59	130	73

ETcr is the plant water requirements (mm/month); and
 $In = ETcr - Neff$ is the net irrigation requirements
 (mm/month).

The result is shown graphically in the figure:

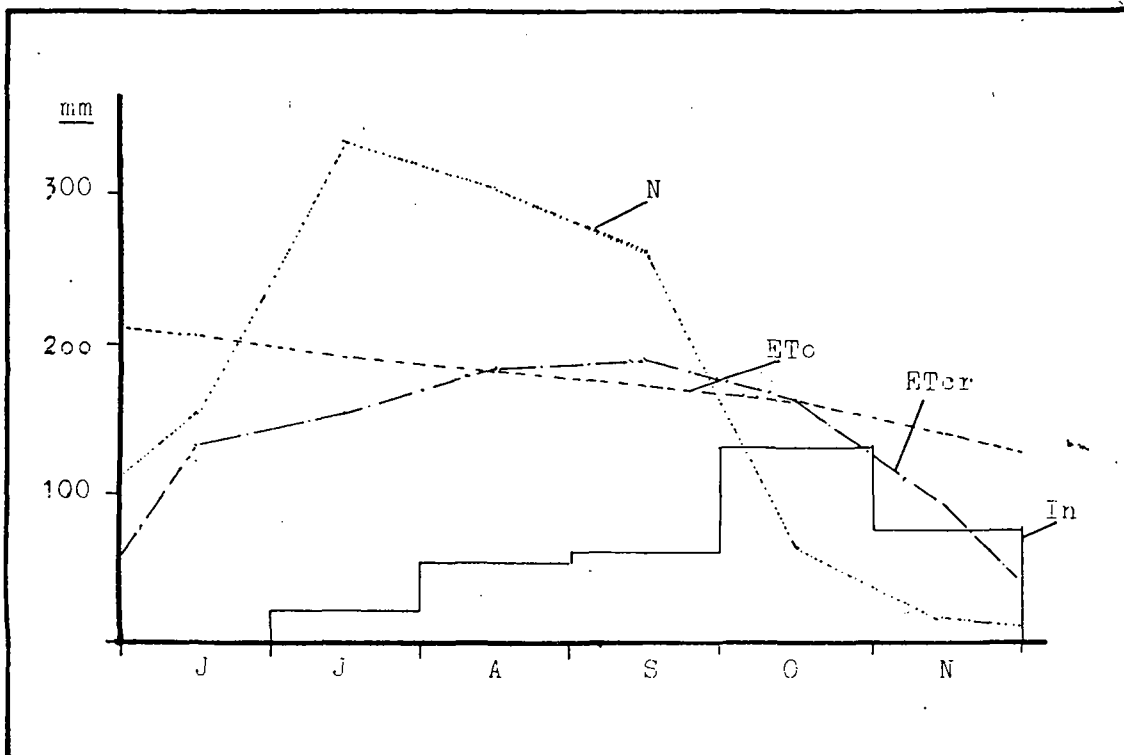

In June there is about as much effective rainfall as there is plant water requirement, therefore no irrigation is needed.

The very high rainfall from July to September will help to leach eventual salts out of the soil, so no special leaching-irrigation is needed.

The maximum irrigation requirement is in October, with $In (max) = 130$ mm.

The total irrigation efficiency is estimated at $Eg = 0.3$ (see page 57.), which gives

$$I = In (max) / Eg = 130 / 0.3 = 433 \text{ mm}$$

which have to be supplied to the irrigation scheme.
 1 mm corresponds to $10 \text{ m}^3/\text{ha}$, so, in October each hectare has to be supplied with $433 \cdot 10 = 4330 \text{ m}^3/\text{ha} \cdot \text{month}$.

The water rights allow intake from the river of 20 l/sec in October.

When all this water-supply is used for irrigation, the irrigable area can be computed:

$$\text{irrigable area} = \frac{0.020 \cdot 31 \cdot 24 \cdot 3600}{4330} = 12.4 \text{ ha}$$

The present soil is CLAY LOAM with 10-18 cm of available water per metre, assume 15 cm/metre.

The rooting depth of the cotton shall be 1.30 metres, which gives the

$$\text{available water} = 150 \cdot 130 \cdot 0,50 = 98 \text{ mm}$$

which can actually be used by the plant.

The plant water requirement in October is 130 mm, or $130 / 31 = 4.2$ mm/day, assume 5 mm/day.

Irrigation shall follow when the moisture content in the soil is at about 50 mm under field-capacity (safety-margin, because not all of the 98 mm available water shall be used).

Thus is the irrigation-turn = $50 / 5 = 10$ days.

which means that every 10 days 50 mm (or $500 \text{ m}^3/\text{hectare}$) have to be applied.

In case there is some heavy rainfall, less than this should be applied, to avoid over-irrigation.

It is evident that due to less crop-evapotranspiration the turn is longer in the other months.

The process can also be shown graphically :

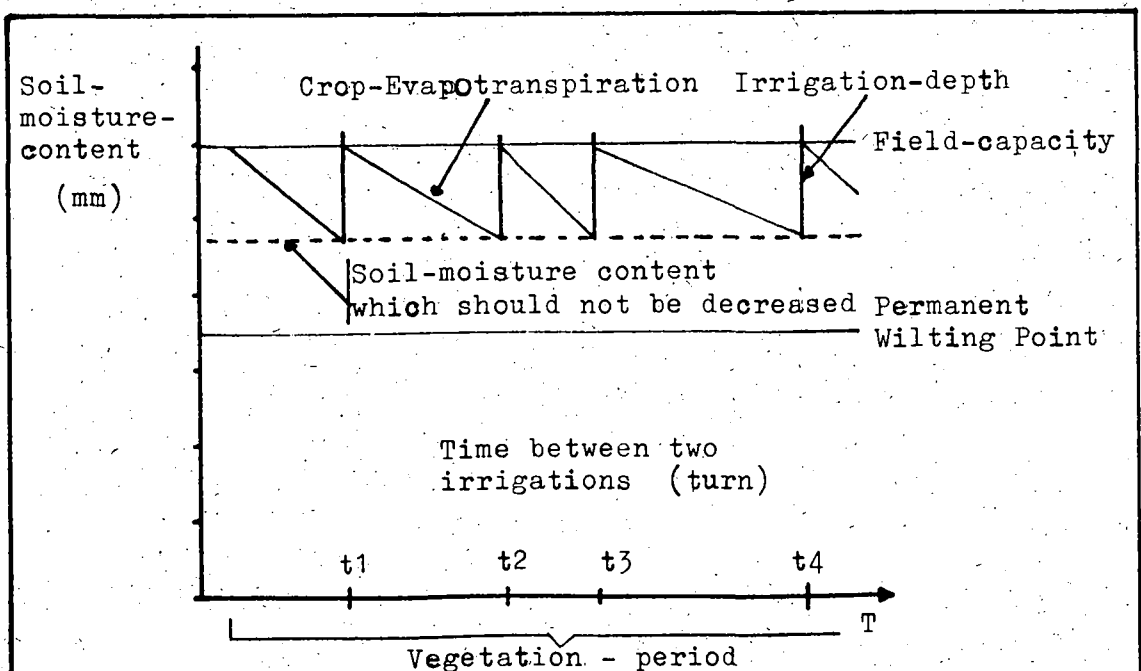

6. Technical Lay-Out of the Irrigation Scheme.

6.1 General Comments on the Irrigation Scheme

An irrigation scheme can technically be classified by its elements:

- water source
- channel system
- irrigation method

For each element different variants exist which have to fit the other elements in order to secure efficient water distribution. This must be considered from the beginning of the planning.

The water source determines the amount of water which can be supplied to the system throughout the year. A poor water supply and/or an expensive technical lay-out of the source requires careful use of the water and therefore also a possibly expensive channel-system.

The maximum amount of water supplied determines the channels cross-section. The elevation of the source has to be high enough to supply water to the lowest point of the system.

The selection of the irrigation method depends on the channels and the water source as far as its capacities and availability are concerned.

The figure which follows gives a general view of an irrigation scheme with its typical elements. The channels are named after their importance, so that the main channel, or primary channel, supports the water from the source to the fields; the distribution or secondary channels divide it; and, the tertiary or lateral channels lead it to the fields.

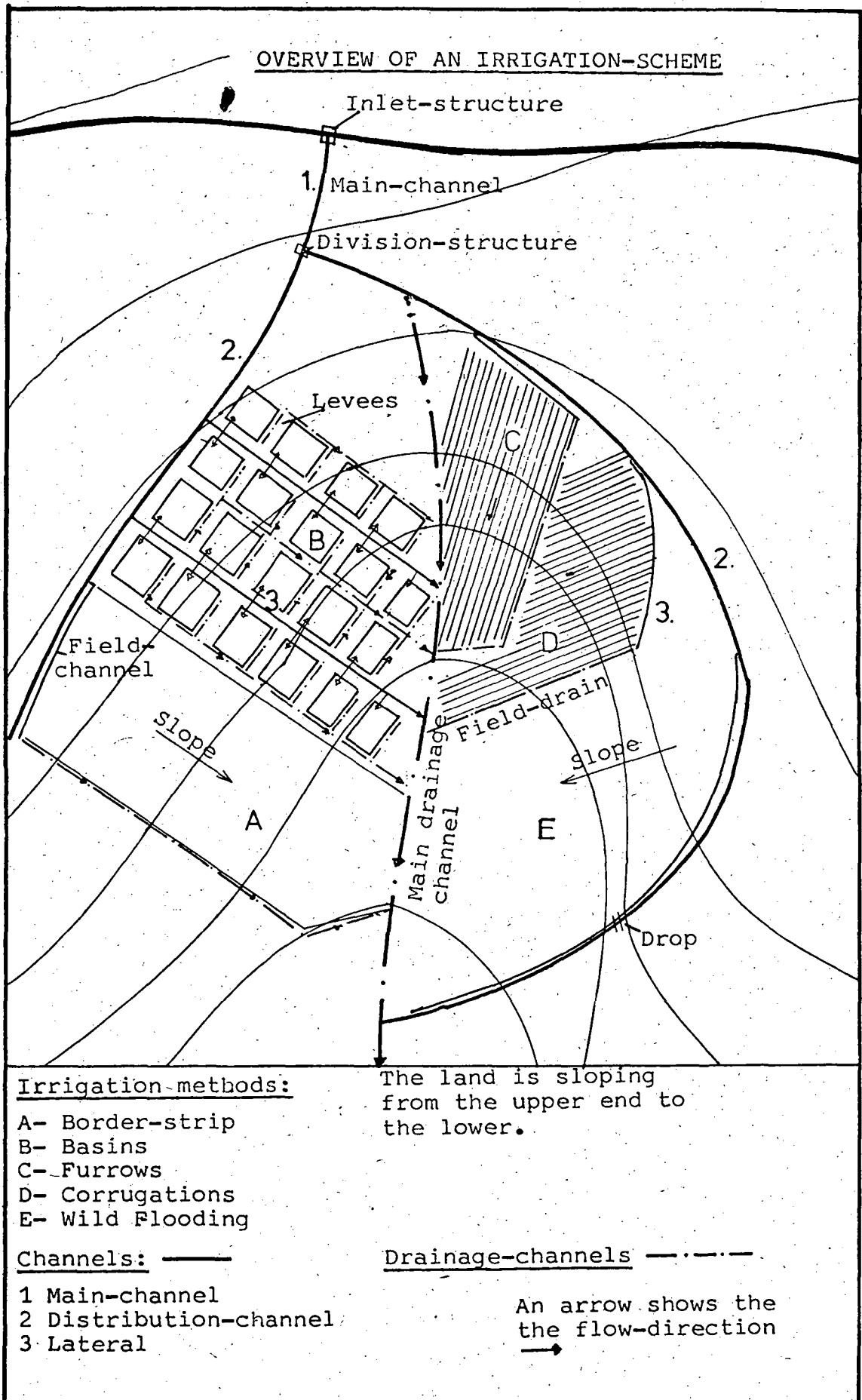

6.2 Water Source

There are two possible ways of obtaining the irrigation water:

- supplying it by gravity from suitable rivers, springs, etc.
- lifting the water from rivers, lakes, wells, etc.

In general, GRAVITY SUPPLY is more economic because, once installed, it can be managed just by gravity and does not require too much maintenance work. However, the investment is quite high due to necessary materials like concrete and a high labour-input.

Technically an inlet structure is needed. A dam or barrage might become necessary to elevate the water level.

In most cases, when constructing the dam, the normal water-course will have to be changed to enable excavation for the foundation. A deep foundation to an impermeable layer and a stable inlet structure are absolutely necessary to secure the long life of the structure. Dams may lead to unforeseen changes of the water-course. Therefore, special skills are needed.

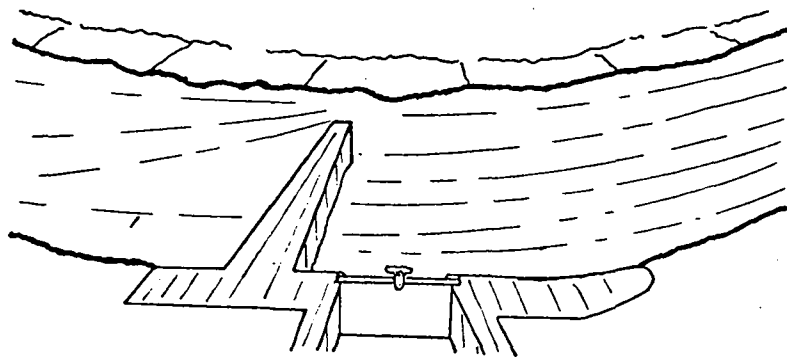

The picture shows a GROIN, which is a structure built from the bank of a river transverse to the current. Groins may be permeable or impermeable.

The system is designed for the peak demand, therefore most of the time it delivers more water than needed for irrigation, provided it is available in the river. This excess water can be used for other purposes.

With PUMPING SYSTEMS every cubic metre of water raised to the irrigation level costs a certain amount; thus the maintenance of high irrigation efficiency is important. This also means high investment costs of the channel-system. To reduce consumption of fuel or electricity, systems using renewable energies should be used. (see GATE Module S 2/2)

There also exist many man- or animal-driven devices. Their maximum possible life-discharges are given below:

MAXIMUM LIFT DISCHARGE (in m³/hour)
depending on a loss of head of

Lift (m)	0 %		50 %	
	Manual	Animal Driven	Manual	Animal Driven
0.5	115	540	58	270
2.00	14	135	7	67
5.00	6	54	3	27
10.00	3	27	2	13
20.00	1	13	1	7

1)

The following gives the range of some possible devices:

- a scoop can lift 8m³/h over about 1 m difference in elevation.
- an archimedean screw about 15 m³/h over 0.5-1.0 m.
- a chain-pump about 15 m³/h over 5 m.
- a rope and bucket lift about 6-10 m³/h over 10-30 m.

The selection of the water-supplying device depends primarily on locally available experience and skills. Therefore it is not discussed any further here.

6.3 Channels

When making the channel-outline, the following points have to be considered:

- alignment (6.3.1)
- dimensions (6.3.2)
- flow control (see Chapter 7)

1) Table received from P. Wolff, Witzenhausen

6.3.1 Alignment

Alignment is mainly determined by the topography. Two benchmarks are the elevation of the inlet and the necessary water-level in the tertiary channels (about 15 cm above field-level). Water only flows under the influence of gravity and differences in elevation have to be reduced slightly.

Normally the alignment will be determined from the topographic map (contour lines) and parallel to that the alignment of the drainage channels.

The main channel takes its course along the highest elevation, the main-drainage channel along the depression. The secondary channels will follow the natural slope (or slight elevations) and the tertiary channels along the contour lines.

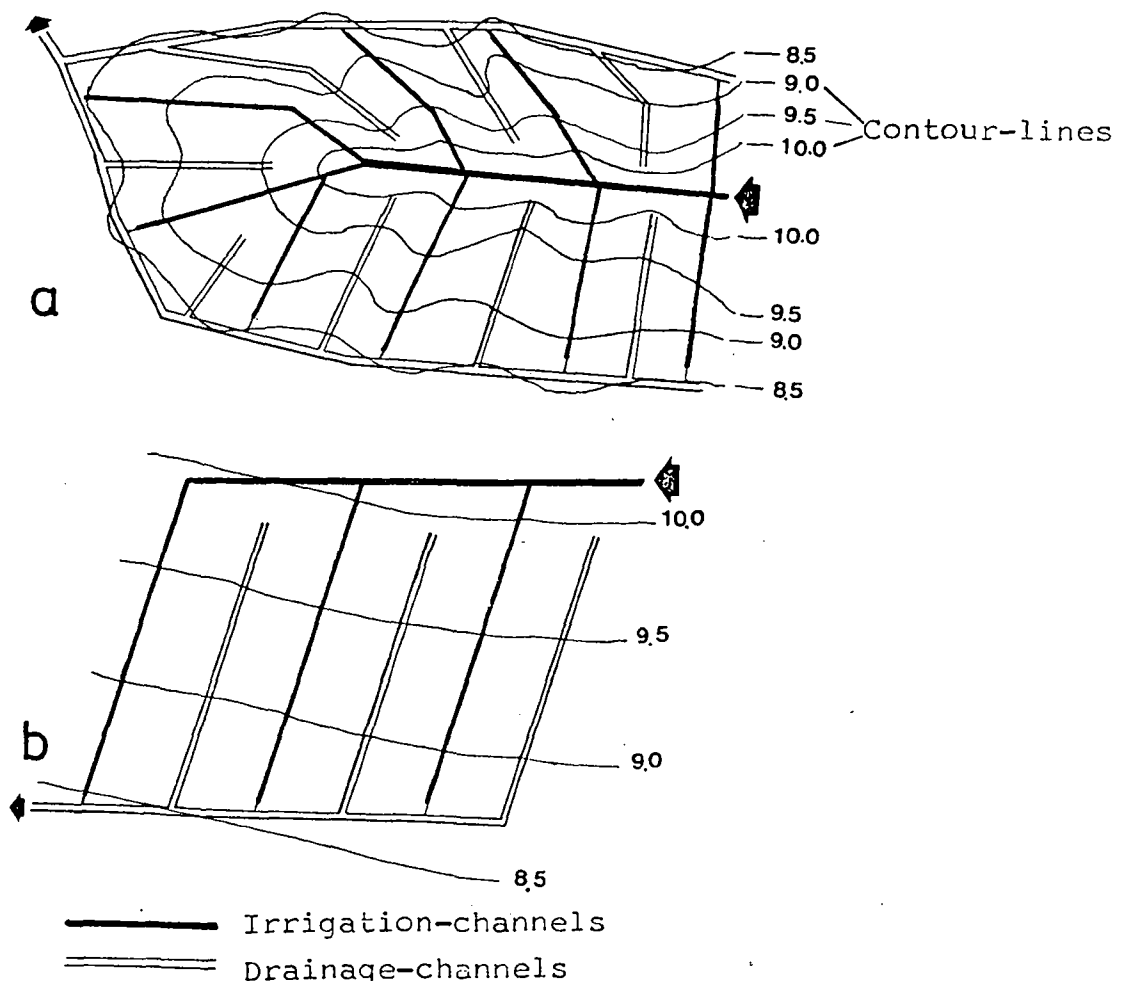

ALIGNMENT of irrigation- and drainage-channels
 a) in unevenly sloping land
 b) in evenly sloping land

6.3.2 Dimensions

-- Base Amount of Water --

The base amount of water for the design can be taken from the experience of other irrigation projects. In most cases this amount of maximum transport water will have to be calculated. Decisive is the maximum plant water requirement: max I_n (mm/month). The maximum supply per hectare is:

$$q_n = \frac{\max I_n}{259} \quad (l/s \cdot ha)$$

Multiplying this by the irrigated area F (ha); the total amount of water q_g is calculated:

$$q_g = F \cdot q_n \quad (l/s)$$

Due to losses in the field and in the channels; the distribution efficiency has to be added:

$$q_z = \frac{q_g}{E_g} \quad (l/s)$$

$$E_g = E_a \cdot E_d \quad (\text{see page 58})$$

This amount of water serves as a base for dimensioning the main-channel. If the system is operated only during part of the day (for example 8 hours), q_z has to be increased. (In this case by the factor of $24/8 = 3$) This will be the maximum appearing channel capacity.

The capacity of the secondary channels depends on the area of the fields which they serve. To ease dimensioning as well as construction, this will be the same (for all).

With a well-designed rotation plan (see Chapter 7) a small number of fields can be served at the same time. This means small necessary capacities. Tertiary channels will be laid out to the maximum water requirement of the largest field.

In all channels an additional FREEBOARD of 7-15 cm has to be added to the maximum calculated water-depth. This is to secure the channel-banks as well as for safety against unforeseen high flows.

The dimensions of the channels should be slightly higher anyway to allow flexibility.

6.3.3 Channel-Lining

To reduce seepage, channels can be lined with an impermeable material. Seepage not only causes low efficiency but also can lead to water-logging in the channels. EARTHEN CHANNELS necessitate high maintenance because weeds and deposits have to regularly be removed. Weeds reduce proper flow and increase losses by evapotranspiration.

For this reason LINED CHANNELS could be favoured, but they are characterised by high costs. With low erosion potential, high water velocities are possible, therefore smaller dimensions can be used. This means less excavation work. Also, less maintenance is necessary.

On permeable soils (sand) it is essential that the channels be lined with impermeable soil (clay, loam). These soils can possibly be found nearby. Losses can be reduced considerably, but lining does not improve hydraulical characteristics and the erosion hazard is only slightly reduced.

Lower costs make earthen channels more favourable for small scale irrigation.

6.3.4. Earthen Channels

Construction can be done without machinery and with locally available materials. In many cases satisfactory results are obtained by manual work and simple tools. However it is done, construction must be carried out with great care because the channels are the skeleton of an irrigation project and shall last for a long time.

DISCHARGE, Q (m^3/sec) depends on the water sectional area F (m^2) and flow velocity v (m/sec) in the formula:

$$Q = F \cdot v \quad (\text{m}^3/\text{sec})$$

When Q is given (see Chapter 6.3.2), F and v will have to be chosen according to the soil and slope.

The side slopes are determined by the lining material:

<u>SUITABLE CHANNEL SIDE SLOPES</u>		
<u>FOR DIFFERENT EARTH MATERIALS</u>		
Material	Slope	
	Vertical	/ Horizontal
Soft, sandy loam	1	: 3
Clay loam, sandy clay	2	: 1
Clays	2	: 3
Rock	1	: 1

The sectional area should be small to reduce construction work. This leads however, to higher flow velocities which are limited due to the erosion hazards.

<u>SUGGESTED MAXIMUM WATER VELOCITIES FOR DIFFERENT</u>	
<u>EARTH MATERIALS</u>	
Material	Velocity m/s
Sand	0.5
Sandy loam	0.6
Alluvial silt	0.8
Loam	0.9
Clay	1.2
Gravel	1.2

If the velocity is too great the material on the sides and the bed of the channel will be eroded by the water.

If the maximum water velocity is exceeded, DROP STRUCTURES in the channels must be provided. These will have to be sufficiently strengthened, for example, by putting rocks or bricks behind the drop. The drop-structure can, and should be, combined with another structure like a weir.

The velocity is related to the roughness of the channel, n , the hydraulic mean radius, R , and the slope, I , in the formula of MANNING-STRICKLER:

$$v = \frac{1}{n} \cdot R^{2/3} \cdot I^{1/2}$$

Increasing ROUGHNESS of a channel means increasing friction between water and the bed and slopes. In this way velocity is reduced. The table below gives values for n for typical conditions:

<u>COEFFICIENTS OF ROUGHNESS (n)</u> <u>FOR DIFFERENT TYPES OF CHANNEL</u>	
Type of Channel	n
Earth, straight and uniform	0.016-0.025
Earth, winding and sluggish	0.025-0.040
Rough stoney beds, weeds on earth banks	
Channels with weeds and bushes	0.025-0.035
Concrete	0.012-0.018

The HYDRAULIC MEAN RADIUS R is obtained by dividing the sectional area F by the wetted perimeter U (thus $R = F / U$).

The wetted perimeter of a water cross-section is the length of the boundary between the water and the sides of the channel, given in metres.

The optimal hydraulic mean radius is obtained with a semicircular profile, but this is not constructable with earthen channels.

b = bed width
 t = depth
 k/l = side slope

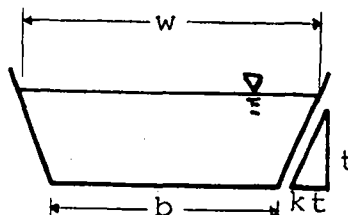

Water surface width

$$w = b + 2 \cdot k \cdot t$$

Area

$$F = \frac{w + b}{2} \cdot t = b \cdot t + k \cdot t^2$$

Wetted Perimeter

$$U = b + 2 \cdot t \cdot \sqrt{1 + k^2}$$

Hydraulic mean radius

$$R = \frac{b \cdot t + k \cdot t^2}{b + 2 \cdot t \cdot \sqrt{1 + k^2}}$$

Hydraulic optimal is $k = 0.58$

-- Slope --

The slope of the channel should be the slope of the land on the proposed channel alignment. Relatively small changes in slope lead to relatively large differences in velocity.

Varying the slope will become necessary in some cases to alter v , because the channel type -which means n - and the mean hydraulic radius will often be given. This can lead to the need for embankments or as well the installation of drops to reduce the flow-velocity.

EXAMPLE for MANNINGS formula :

Given are :

- earth channel $n = 0.025$

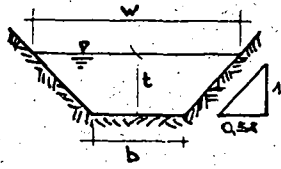

$$b = 0.15 \text{ m}$$

$$t = 0.30 \text{ m}$$

$$k = 0.58$$

$$w = 0.15 + 2 \cdot 0.58 \cdot 0.30 = 0.50 \text{ m}$$

$$F = 0.15 \cdot 0.30 + 0.58 \cdot 0.30^2 = 0.097 \text{ m}^2$$

$$U = 0.15 + 2 \cdot 0.30 \cdot \sqrt{1 + 0.58^2} = 0.84 \text{ m}$$

$$R = \frac{0.097}{0.84} = 0.115 \text{ m}$$

$$I = 0.15\% \hat{=} 0.0015$$

$$v = \frac{1}{0.025} \cdot (0.115)^{2/3} \cdot \sqrt{0.0015} = 0.37 \text{ m/s}$$

$$\text{Discharge } Q = F \cdot v = 0.097 \cdot 0.37 = 35.9 \text{ l/s}$$

$$I = 0.25\% \hat{=} 0.0025$$

$$v = 0.47 \text{ m/s}$$

$$Q = 45.9 \text{ l/s}$$

6.4 Surface Irrigation Methods

For the purpose of small-scale irrigation, only surface irrigation methods are suitable, with the exception of trickle-irrigation which is very expensive and quite complicated. This also applies to sub-soil and overhead irrigation (sprinkler). Therefore these methods are not described in this context.

A general view of the different methods of surface irrigation is given in the table on the following page.

Surface irrigation is the most common method in the world and its tradition is thousands of years old. It is also known under the name of gravity irrigation because water is moved under the influence of gravity without using energy, except for the water lifting in some areas.

Its bases are the conditions of flowing water and the infiltration characteristics of the soil. During the years different methods evolved from different natural situations and became well-adapted to the latter.

These are:

- soil: infiltration, permeability, erosion hazards
- topography: uniformity and slope
- water: availability
- crops: grown in rows or faced

A wrong choice of the method can lead to deterioration of the soil (erosion, salinisation, washing-out of the nutrients), and/or high-water losses.

SURFACE IRRIGATION METHODS AND CONDITIONS OF USE

Irrigation method	Suitabilities and conditions of use				Remarks
	Crops	Topography	Water supply	Soils	
Small rectangular basins	Grain, field crops, orchards, rice	Relatively flat land; area within each basin should be levelled	Can be adapted to streams of various size	Suitable for soils of high or low intake rates; should not be used on soils that tend to puddle	High installation costs. Considerable labour required for irrigating. When used for close-spaced crops, a high percentage of land is used for levees and distribution ditches. High efficiencies of water use possible.
Large rectangular basins	Grain, field crops, rice	Flat land; must be graded to uniform plane	Large flows of water	Soils of fine texture with low intake rates	Lower installation costs and less labour required for irrigation than with small basins. Substantial levees needed.
Contour checks	Orchards, grain, rice, forage crops	Irregular land; slopes less than 2 percent	Flows greater than 30 litres (1 cubic foot) per second	Soils of medium to heavy texture which do not crack on drying	Little land grading required. Checks can be continuously flooded as for rice, water ponded as for orchards, or intermittently flooded as for pastures.
Narrow borders up to 5 metres (16 feet) wide	Pasture, grain, lucerne, vineyards, orchards	Uniform slopes less than 7 percent	Moderately large flows	Soils of medium to heavy texture	Borders should be in direction of maximum slope. Accurate cross-levelling required between guide levees.
Wide borders up to 30 metres (100 feet) wide	Grain, lucerne, orchards	Land graded to uniform plane with maximum slope less than 0.5 percent	Large flows, up to 600 litres (20 cubic feet) per second	Deep soils of medium to fine texture	Very careful land grading necessary. Minimum of labour required for irrigation. Little interference with use of farm machinery.
Wild flooding	Pasture, grain	Irregular surfaces with slopes up to 20 percent	Can utilize small continuous flows on steeper land or large flows on flatter land	Soils of medium to fine texture with stable aggregate which do not crack on drying	Little land grading required. Low initial cost for system. Best adapted to shallow soils since percolation losses may be high on deep permeable soils.
Benched terraces	Grain, field crops, forage crops, orchards, vineyards	Slopes up to 20 percent	Streams of small to medium size	Soils must be sufficiently deep that grading operations will not impair crop growth	Care must be taken in constructing benches and providing adequate drainage channels for excess water. Irrigation water must be properly managed. Misuse of water can result in serious soil erosion.
Straight furrows	Vegetables, row crops, orchards, vineyards	Uniform slopes not exceeding 2 percent for cultivated crops	Flows up to 350 litres (12 cubic feet) per second	Can be used on all soils if length of furrows is adjusted to type of soil	Best suited for crops which cannot be flooded. High irrigation efficiency possible. Well adapted to mechanized farming.
Graded contour furrows	Vegetables, field crops, orchards, vineyards	Undulating land with slopes up to 8 percent	Flows up to 100 litres (3 cubic feet) per second	Soils of medium to fine texture which do not crack on drying	Rodent control is essential. Erosion hazard from heavy rains or water breaking out of furrows. High labour requirement for irrigation.
Corrugations	Close-spaced crops such as grain, pasture, lucerne	Uniform slopes of up to 10 percent	Flows up to 30 litres (1 cubic foot) per second	Best on soils of medium to fine texture	High water losses possible from deep percolation or surface runoff. Care must be used in limiting size of flow in corrugations to reduce soil erosion. Little land grading required.
Basin furrows	Vegetables, cotton, maize and other row crops	Relatively flat land	Flows up to 150 litres (5 cubic feet) per second	Can be used with most soil types	Similar to small rectangular basins, except crops are planted on ridges.
Zigzag furrows	Vineyards, bush berries, orchards	Land graded to uniform slopes of less than 1 percent	Flows required are usually less than for straight furrows	Used on soils with low intake rates	This method is used to slow the flow of water in furrows to increase water penetration into soil.

Source: /1/

6.4.1 Basin Irrigation

This is the simplest, in principle, of all methods. The field is divided into small units so that each has a nearly level surface. Levees (ridges, bunds) are constructed around the areas forming basins (plots) within which the water can be controlled. The basins are filled to the desired depth and the water is retained until it infiltrates into the soil, or the excess is drained off.

In irrigating RICE, the depth of water can be maintained for considerable periods by allowing a continuous flow into the basins.

Other CROPS like cotton, grain, maize, groundnuts, grams, lucerne, pasture, etc. are suited to this system of irrigation. Normally they receive their water under a fixed turn interval. (See chapter 7.2)

Basin irrigation is NOT SUITED to crops which are sensitive to wet soil conditions around the stems, or for annual crops on soils which crust badly when flooded (large day-share).

An efficient DRAINAGE SYSTEM, which can be difficult to construct because of a flat surface, can become necessary on (clay) soils with very slow infiltration rates, where standing water reduces soil aeration or creates a favourable environment for the breeding of mosquitoes.

-- Basin Size --

Basin size may vary from one square meter to several hectares. In order to ease cultivation, the plots should not be too small. On the other hand, the size is limited by topography.

► It should be possible to fill the plot in a short time to the uniformly desired level.

High water application rates enable large plots, but they also increase the danger of erosion. Small size is needed when the infiltration rate is high because otherwise it might happen that the water percolates at the head of the plot before other water reaches the end of the plot.

► In increase impermeability of the soil, paddy-farmers grub up the upper soil-layer (puddling). When the soil-water-mixture deposits, the small fractions of the soil fill up the pores and thus reduce infiltration.

<u>SUITABLE AREAS FOR BASINS (sq. metres)</u>				
Flow Litres/sec	Soil Type			
	Sand	Sandy loam	Clay loam	Clay
10	65	200	400	700
20	130	400	800	1400
50	325	1000	2000	3500
100	650	2000	4000	7000

Source: /2-24/

The SHAPE OF THE PLOTS should be suited to the topography. On evenly sloping land the plots will be rectangular to ease the alignment of the channels. With increasing slope the basin-width will descend for two reasons:

- The (fertile) top-layer of the soil is mostly rather shallow, especially on slopes. Not too much of this soil should be removed.
- Not too much soil should have to be moved because only simple equipment is used.

Normally the step between terrace levels should not be more than 15 cm.

The plots may follow the contour lines, but with dykes they have to be made out of solid material.

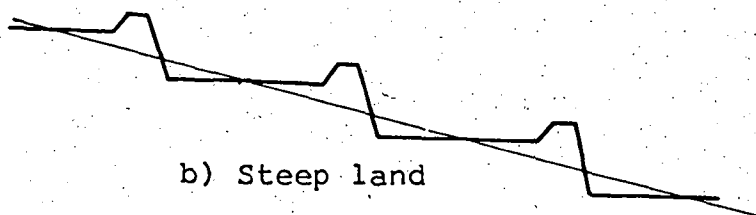
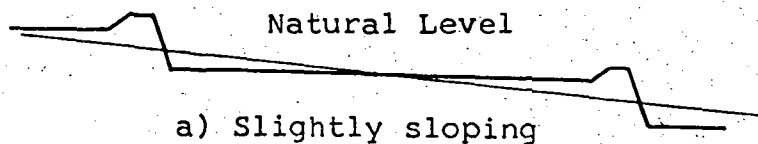

Different basin-sizes for different slopes

The size of the basins on each terrace can be determined from the following table:

<u>SUITABLE SPACING OF TERRACE STEPS FOR BASINS</u>	
(metres)	
<u>Land Slope %</u>	<u>Spacing</u>
0.1	150-60
0.2	75-30
0.5	30-12
1.0	15-6
1.5	10-4
2.0	7.5-3
3.0	5-2
4.0	3.75-1.5

Source: /9/

The shape of the fields should be regular.

An important factor is the LEVELLING of the basins. This can be done by a simple method:

▶ The basin is filled with water so that only part of it is covered. The protruding soil is excavated and brought to the lower (wetted) parts of the basin.

The LEVEES should be constructed in a way that they are stable for some years. In mechanical operations they are reconstructed after every harvest.

When the water is filled to it's highest level, they should still be 10 to 20 cm higher. This results in a total height of about 35 cm. A trapezoidal cross-section is widely used, with a base-width of 150 cm and a top width of 50 cm to provide a pathway to the field.

It should not be forgotten that the soil may settle as time passes.

It is possible to plant on the banks. (This may lead to higher water requirements!)

-- Filling the basins with water --

The filling of the basins will vary according to the relative positions of the plots.

a.) Each field (plot) gets it's water seperately from the tertiary channel and delivers the surplus-water to the drainage (excessive rainfall). With small basin sizes this could lead to huge and thereby expensive channel numbers.

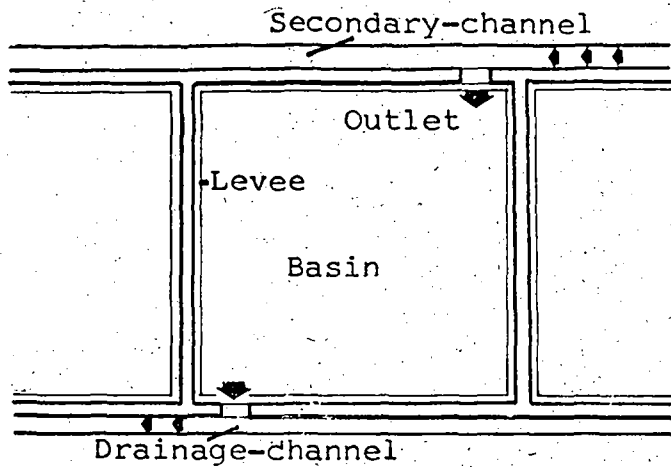

Method (a)

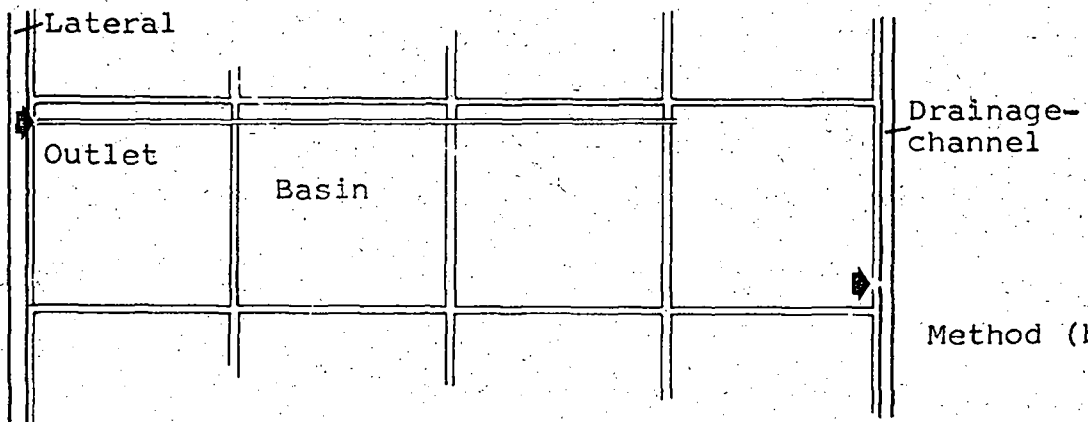

Method (b)

For this reason, several plots are fed in succession from the same field-inlet.

b.) The water is allowed to flow in the borrow-furrow alongside a levee through gaps in the cross levees to the lowest of the tier of basins. When this is filled to the required depth, the gap in the cross levee of that basin is closed and the next higher basin is filled, and so on. This often results in uneven distribution of the water on soils which take water readily, unless the entire tier of basins can be filled quickly.

Care must be taken to prevent breaks in the cross levees when all the basins are filled. This could cause serious erosion.

c.) The following method is often used on soils with a high initial intake rate which decreases to a much lower rate after an hour or two. The highest of a tier of basins is filled first, and the water remains for the necessary length of time. The lower cross levee of the first basin is then opened and the next basin is then filled with the excess water together with water being released from the supply ditch, and so on. The water flowing from the supply ditch can be carried through the basins in a channel, the bottom of which is slightly lower than the normal ground surface, so that it will also serve as a drain.

d.) Continuous supply is normally used for irrigating rice. With this method the water in the basin is kept at a constant level (5-15 cm). This results in high water losses because normally the inflow cannot be regulated exactly according to varying plant water consumptions.

The depth of water will have to be regulated with the outlets if there is a tier of basins and continuous supply. The lowest basins should have an outlet to the drain to facilitate harvesting and to allow a quick emptying of all the basins if it is necessary.

All outlets have to be secured with stones to prevent erosion.

An example for calculating the inflow is to be found in Chapter 7.1. (see page 69)

6.4.2 Border Irrigation

This method will normally not be used for small-scale irrigation because it is more suitable for very large areas and a relatively large flow of water is needed.

The border strips are built, like the basins, with levees on the sides and are slightly sloped. The irrigation water flows from the upper end of the field in a large front down the field, while part of it is percolating. The supply quantity has to be provided in such a way that the field will be wetted regularly and that no excess water has to be drained off.

From these facts it is clear that the field must be very even. The fields have to be prepared very carefully, normally with the help of machines. Under these conditions border strip irrigation can be quite successful.

6.4.3 Furrow Irrigation

This method is particularly suitable for deep soils with moderate infiltration rates, and for irrigating row crops (vegetables, cotton, maize, potatoes, etc.). The water runs down the field in small channels (furrows), seeps into the bottom and sides of the furrows, and thus covers only part (20-50%) of the soil-surface. In this way evaporation-losses are reduced, and it is possible to cultivate crops which are subject to injury if water covers the crown or stems of the plants. The water has to percolate into the deep soil as well as into the width to well-moisten the rooted soil. Therefore the soil has to have a good infiltration-ability in all directions.

▶ Narrow, deep furrows promote the horizontal advancement of the water, but they also accelerate the danger of erosion.

Wide and shallow furrows promote the vertical advancement of water.

The furrow's cross-section also depends on the depth of water to be applied. U- or V-shaped furrows are widespread and are easily produced with simple equipment (heel, plow).

To increase percolation in soils which take water slowly, wide furrows are used to increase the wetted perimeter. (bottom width, 15-25 cm). For this purpose, in every case, the furrows will not be smoothed.

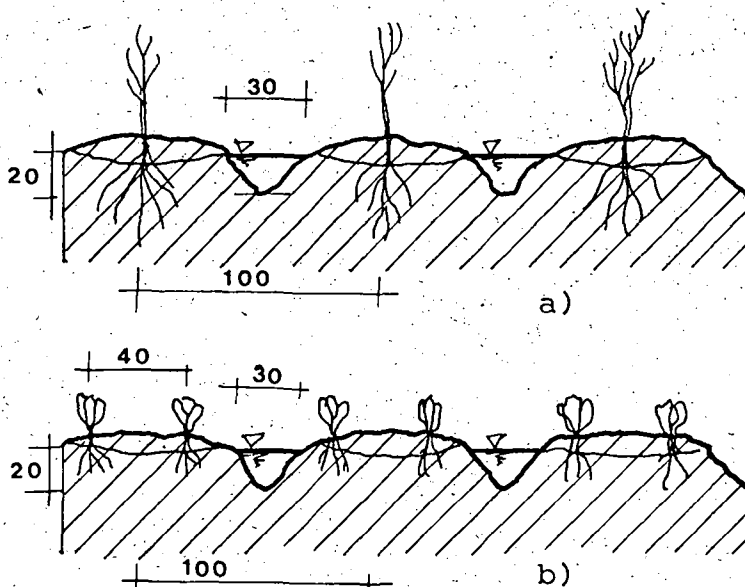

Irrigation Furrows

- a) Used for most crops
- b) Especially used for cultivating vegetables

-- Cultivation, Salinisation --

Normally the crops are planted in the middle of the ridge. On soils with little vertical permeability one row can be planted at each side of the furrow. The ridges are wetted solely by capillary movement to the soil surface.

For this reason, the plants are especially liable to salinisation when irrigation water with a high salt content is used. The highest salt concentration will be found on the top of the ridge. In this case, the crops should be planted on the furrow slopes.

-- Furrow Spacing --

The spacing of the furrows will depend on the crops to be irrigated, the type of tillage to be used, and the wetting pattern obtained by the lateral movement of water in the soil.

The main objective is to make sure that the lateral movement of the water between adjacent furrows will wet the entire root zone before it moves beyond the depths from which the roots can extract the soil water.

To obtain complete wetting of sandy soils to depths of 1.2-1.8 m, the furrows usually should not be placed more than 50 cm apart. In uniform clay soils, furrow spacings of 120 cm or more may be advisable.

The lay-out of the furrows on uniform slopes will be rectangular to the tertiary channels, i.e. in the direction of the gradient.

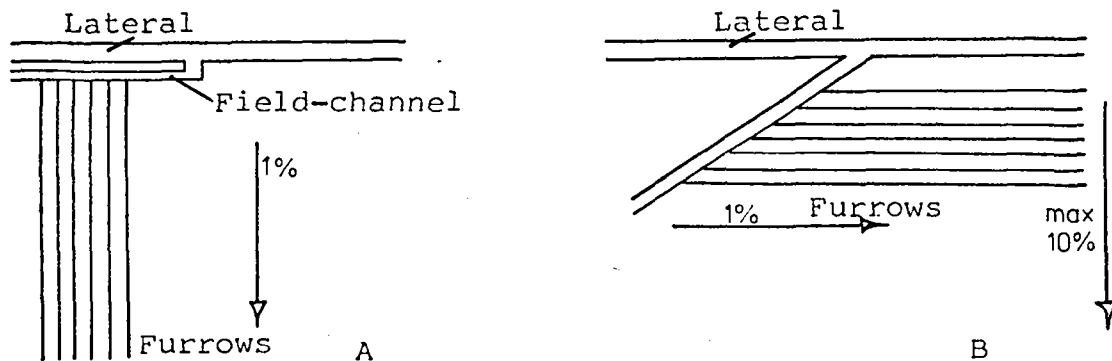

Direction of furrows in :

- A - evenly and slightly sloping land
- B - steep land

With increasing slope, contour-furrows should be used, i.e. they have an angle smaller than 90° to the contour lines. The transverse gradient should not exceed 10° .

-- Furrow Length --

Forming long furrows with an even slope is quite difficult. The uniformity of water application usually decreases as the furrows become longer.

The most suitable furrow length has to be discovered by trial and error. The following notes should serve as guides:

The length is mainly limited by topography and the uniformity of the soil-type. When different soil types (i.e. infiltration rates) occur, the fields have to be sub-divided accordingly.

Furthermore, the slope determines the length. Flat slopes may cause the water not to reach the end of the furrow. The same applies to an insufficient inflow.

Cultural practices may also influence the length of furrows. Where abundant labour is available and furrows are constructed by hand and/or lots of different crops are cultivated, very short furrows may be most suitable.

Therefore, the following table should only be considered a rough guide:

SUGGESTED MAXIMUM LENGTHS OF CULTIVATED FURROWS FOR DIFFERENT SOILS, SLOPES, AND DEPTHS OF WATER TO BE APPLIED (lengths in metres)								
Furrow Slope Percent	Average depth of water applied (mm)							
	75	150	300	50	100	200	50	100
	Clays			Loams			Sands	
			Metres.....			
0.05	300	400	400	120	270	400	60	150
0.1	340	440	500	180	340	470	90	190
0.2	370	470	620	220	370	530	120	250
0.5	400	500	750	280	370	530	120	250
1.0	280	400	600	250	300	470	90	220
1.5	250	340	500	220	280	400	80	190
2.0	220	270	400	180	250	340	60	150

Source:/1/

-- Furrow slopes, Flow rate --

Success in furrow irrigation depends largely on the uniformity of the slope. The slope serves to distribute water along the furrow as well as for drainage. The slope also determines the flow-velocity. High velocity can be desirable to ease even distribution, but also increases the danger of erosion. Therefore certain speeds should not be exceeded. They depend on the type of the soil.

Soils with a lot of sand and little loam are especially affected. Clay soils are highly erosion-resistant. The maximum, critical slope is about 2%.

The maximum non-erosion flow Q_m can be estimated from the following formula:

$$Q_m = \frac{0.6}{I} \quad (l/sec)$$

I = Slope, given in %.

The flow rate should be reduced when the water reaches the end of the furrow, but this requires special skill.

6.4.4 Corrugation Irrigation.

Corrugation irrigation is comparable to furrow irrigation but corrugations are shallower (maximum of 10 cm) than furrows, and the soil surface is even. Therefore it is often used for irrigating close-growing crops, such as small grains, lucerne, or pasture on steep slopes.

Flooding of the corrugations and the whole surface can be used to obtain good moistening, especially in the initial growth stage, and for leaching.

Corrugation irrigation is most suitable for use on silt loam or clay loam soils, in which the lateral movements of water take place easily. This method is not recommended for sandy soils with high intake rates, because excessive water will be lost by deep percolation before the entire soil surface is wetted.

Wetting of the upper layer is only obtained by capillary movement, therefore the danger of salinisation is relatively high.

-- Land Preparation, Slopes --

Land grading is generally limited to removing minor irregularities on the soil surface. The slopes in the direction of irrigation must be continuous, although not necessarily uniform.

Slopes may vary from 2 to 10%. This depends on the erodibility of the soil and the type of crop being grown.

Slopes rectangular to the corrugations should not be allowed because overflow, which will otherwise occur, causes erosion.

LENGTH AND SPACING OF CORRUGATIONS

Distances in metres

Slope	Percent	Fine-textured clay soils		Medium-textured loam soils		Coarse-textured sandy soils	
		Length	Spacing	Length	Spacing	Length	Spacing
	Metres.....					
Deep-rooted crops or deep soils	2	180	0.75	130	0.75	70	0.60
	4	120	0.65	90	0.75	45	0.55
	6	90	0.55	75	0.65	40	0.50
	8	85	0.55	60	0.55	30	0.45
	10	75	0.50	50	0.50		
Shallow-rooted crops, or shallow soils	2	120	0.60	90	0.60	45	0.45
	4	85	0.55	60	0.55	30	0.45
	6	70	0.55	50	0.50		
	8	60	0.50	45	0.45		
	10	55	0.45	40	0.45		

Source: /1/

Corrugations are usually made after the field has been seeded. They are pressed into the loose soil by using, for example, a corrugator (see figure).

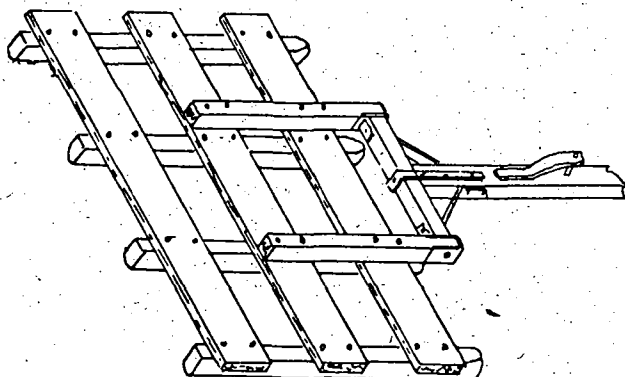

Wooden corrugator with four runners used for pressing small furrows into loose soil. Metal pipes are sometimes used in place of wooden runners.

Source: /1/

The rules governing the flow of water in furrows apply also to corrugations. The flow at the beginning should be as large as safely can be carried in the corrugations without causing erosion.

MAXIMUM NONEROSIVE FLOW RATES THAT SHOULD BE USED IN CORRUGATIONS ON VARIOUS SLOPES	
Corrugation Slope Percent	Maximum Flow Rate Litres per second
2	0.30
4	0.15
6	0.10
8	0.08
10	0.06
12	0.05

Source:/1/

An important advantage of corrugation-irrigation is that a small water inflow is sufficient.

Several corrugations can be served by one field-channel.

6.4.5 Wild Flooding

This method needs relatively little land-preparation but can improve the growth condition of low-income or perennial forage crops quite well.

▶ Stabilising the natural vegetation can help to prevent erosion.

It is applied to (steep) slopes where rain-water will run off quickly and where the shallow upper soil-layer has a low moisture-holding capacity.

The distribution system consists of supply channels and contour ditches. The former run in the direction of the gradient, the latter parallel to the contour lines, with a slope of about 0.5% for a distance of about 30 m.

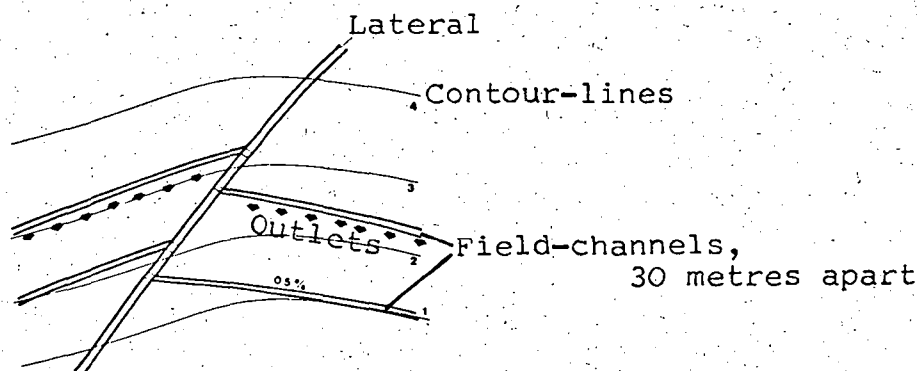

The supply channels should be concrete-lined or be provided with drop-structures.

The water-distribution on the field has to be uniform to prevent formation of trenches which can lead to erosion and prevent the wetting of large parts of the field.

Contour ditches can be built with a hoe or a plow. Into the ditch bank must be placed outlets, spaced 2 or 3 meters apart.

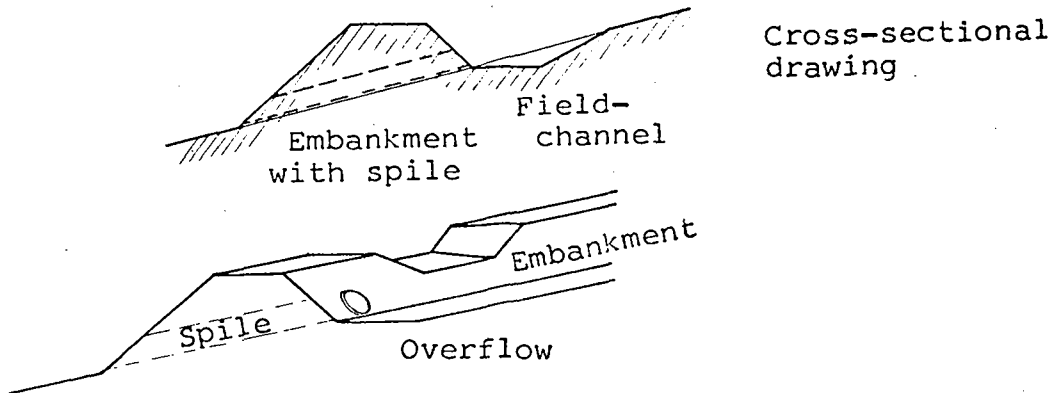

Cross-sectional drawing

Where the ditch banks are stabilised (with concrete linings, for example) it is sometimes possible to distribute the water by overflowing the banks.

Frequency of irrigation can be continuous or by turn.

6.4.6 Efficiency

On its way to the plant, water-losses occur which need to be included in the calculations for irrigation efficiency.

The TOTAL IRRIGATION EFFICIENCY (E_g) is the relation between the amount of water taken from the source in a certain time (Q_g , given in m^3) and the actual plant-water requirements in that time (I_g , also in m^3).

$$E_g = \frac{I_g}{Q_g}$$

E_g is the product of the efficiency of the distribution system (E_d), and the application on the fields (E_a).

$$E_g = E_d \cdot E_a$$

The DISTRIBUTION EFFICIENCY (E_d) is the relation between the total amount of water supplied to the system in a time (Q_g), and the amount of water which reached the field-outlets in that time (Q_f , given in m^3).

$$E_d = \frac{Q_f}{Q_g}$$

The losses are the result of:

- seepage (depending on the lining of the channel).
- evaporation from the water-source.
- inaccurate regulation of water-flow.

To reduce them requires either expensive channel-lining and accurate structures, or more careful operation.

Experience shows that distribution efficiency in small-scale schemes with earth-channels and medium operation-management will be:

$$E_d = 0.4-0.6$$

The APPLICATION EFFICIENCY (E_a) is the relation between the amount of water supplied to the fields (Q_f) and the actual amount of water used by the plants in a certain time (I_g).

$$E_a = \frac{I_g}{Q_f}$$

Losses in the field are due to:

- deep percolation.
- excess-water flowing from the field (over-irrigation).
- evaporation in the field.

Leaching-water will not be counted as a loss, because it secures plant-growth.

Application efficiency depends on the irrigation-method and the field-preparation.

For small-scale irrigation the following efficiencies can be used:

Irrigation Method	E_a
basin, border strip, furrow, corrugation	0.5-0.6
rice in basins	0.3

6.4.7 Special Irrigation Methods

-- Buried Pots¹ --

This method can be used in semiarid and arid climates on sandy to alkaline-sandy soils.

A pot made of burnt clay is buried in specially prepared soil. The regularly-filled in water percolates through the pot's porous sides, and moistens the surrounding soil. In this way cultivation of plants becomes possible.

The method is most suitable for small gardens or for breeding seedlings which will be replanted.

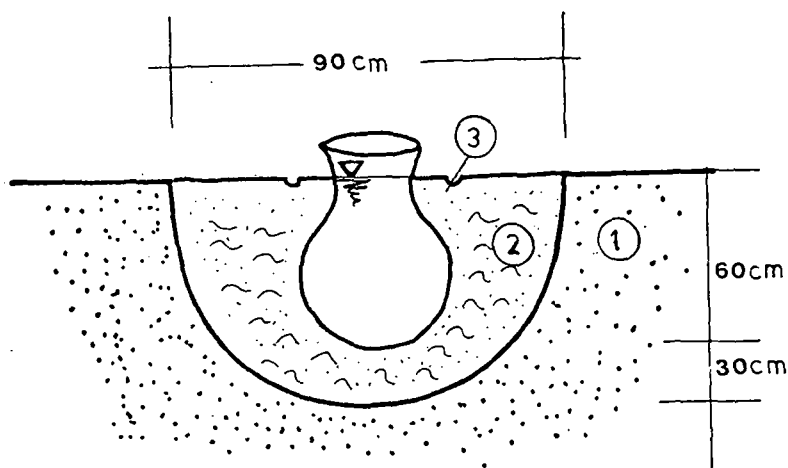

- 1 - Natural Soil
- 2 - Treated Soil
- 3 - Seedbed, about 3 cm around the pot

Special care has to be taken that:

- the pot shall not be glazed.
- the water has to be clean to avoid obstruction of the pores.

1.) Groupe de recherche sur les techniques rurales, GRET, No. T. 160, Paris.

With this method much less water is needed than by a watering can. With good soil preparation, several pots can achieve a sufficient moistening of a large area.

Impermeable soils have to be prepared by adding sand, lime, crushed groundnut-peels, etc.. Sandy soils are prepared by adding compost and a good muddling of the soil with manure.

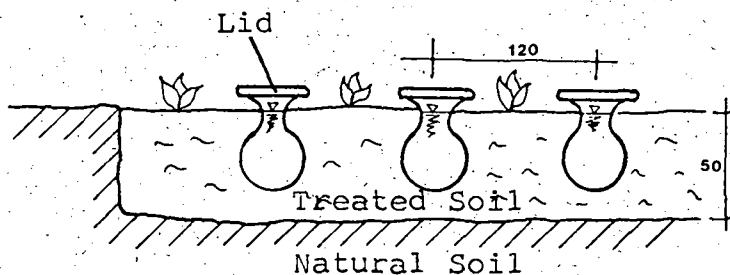

The water requirement is about 2 or 3 litres per day and pot.

The pots must always be covered (lid made of wood, flat rock) to prevent evaporation and access to mosquitoes (breeding place!).

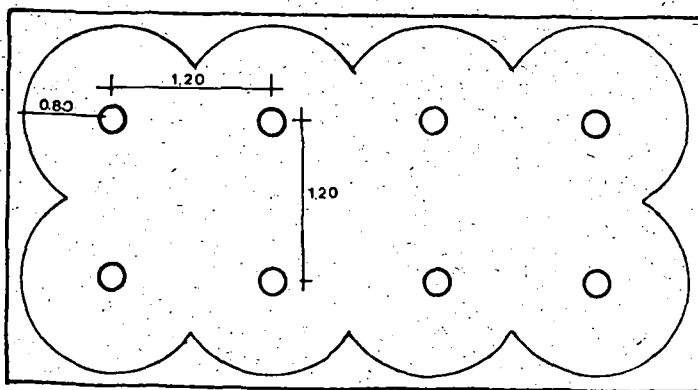

Example of a garden with an area of 12 m² with 8 buried pots

-- Small Catchment Storage¹ --

In some arid zones the small amount of rainfall is just sufficient to supply staple crops (millet or sorghum usually) with moisture. A relatively large area has to be cultivated to secure sufficient yields. The method described below offers the opportunity to cultivate other crops like tomatoes or legumes under these unfavourable conditions.

Part of the cultivated area is prepared as a catchment apron from which run-off is fed into a catchment tank. The adjoining garden is irrigated by watering can using water taken from the tank.

EXAMPLE:

The annual precipitation is 300 mm, the area of the catchment apron 700 m², and the area of the garden 300 m².

210 m³ of rainwater will be annually available collected by the catchment. After percolation and evaporation about 150 m³ are collected in the tank. Due to other losses about 100 m³ can be used. The garden will receive actual precipitation (300 mm) plus $(100 \text{ m}^3 / 300 \text{ m}^2) \cdot 300 = 330 \text{ mm}$ irrigation water, making a total of 630 mm per year. If this is not sufficient, the catchment area has to be enlarged.

The best suited catchment apron is rock. Heavy soils can also be suitable if:

- they have sufficient slope.
- rocks and vegetation are removed.
- the surface is level and stable. The upper soil layer has to be contracted and levelled.

The tank should be watertight. Heavy and alluvial soils are commonly sufficient. In most tanks, soil lining will be necessary. This can be done with brickwork, concrete masonry, and cement plaster. Of the synthetic materials polythene is the least expensive.

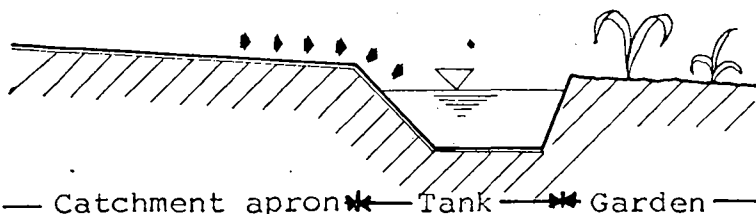

1.) P. STERN, "Small Scale Irrigation." Intermediate Technology Development Group, London, 1979.

-- Manual Irrigation¹ --

With this method, irrigation water is lifted, transported, and applied by human power. The watering-can is commonly known. Another possibility, widely used in Middle America, is to scoop water directly from the water-source onto the fields, which must lie a short distance from the the source.

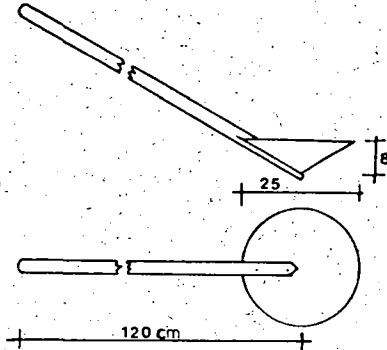

Metal Irrigation Scoop

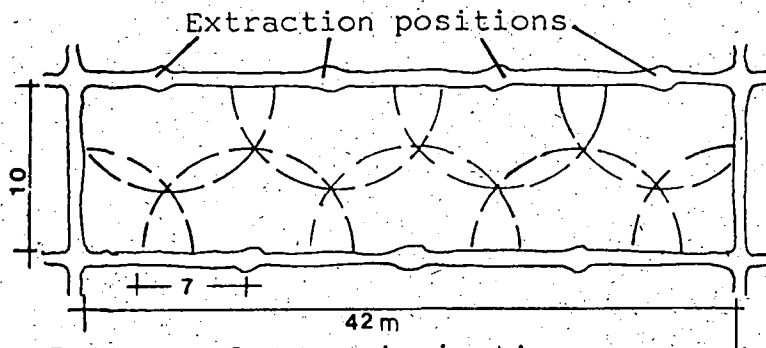

Pattern of Scoop-irrigation

The farmer will determine the irrigation-time by experience. The water is scooped out of the channel surrounding the field until some of it remains on the soil surface. In times of high plant water requirement irrigation is repeated daily.

1.) G.C. WILKEN, "Manual Irrigation in Middle-America." Agricultural Water Management, I, 1977, pp. 155-165.

6.5 Drainage

Drainage includes all processes that remove surplus water from agricultural lands. It includes both the internal drainage of soils (to remove too much moisture) and the collection and disposal of surface run-off.

Over-saturated soils are difficult to cultivate, allow only poor air-circulation, and receive a bad structure.

Water-logging of soils can also occur under natural conditions. In this context we only discuss the drainage because it is at some time necessary in nearly every kind of irrigated agriculture:

- ▶ The success of an irrigation scheme depends to a great extent on a good drainage system.

6.5.1 Soil Drainage

All soils are more or less self-draining. The soil's content of small pores determines its moisture holding capacity, with large pores determining its ability to drain.

When the water-content rises above field-capacity (FK), as in the cases of over-irrigation or heavy rainfall, percolation begins. Natural drainage is the percolation through the pore-channels.

When there is an impermeable layer underneath a permeable one, the water will be retained and water-logging occurs. Drainage in this case will be very expensive. It is then essential to use precisely the necessary amount of needed irrigation water.

When the soil is saturated with water (after heavy rains, over-irrigation) surface run-off begins, depending on the slope. This also occurs in cases where the irrigation supply is higher than the infiltration rate.

This excess water must be drained off.

6.5.2 Drainage Channels

The drainage channel system is built analogous to the irrigation channel system. Each irrigation channel has to have an overflow spillway at its lower level end to safely discharge excess water or water which is not needed for irrigation. At the lower end of the fields will be the field drain which supplies the lateral drain. The main drain collects all drainage water and leads it to a river or lake. (see Figure on page 34).

Each field or lateral irrigation channel has to have an overflow-spillway at its end which leads into a drainage channel. This is to allow too heavy channel drainage (heavy rains, not needed water) a safe escape.

Designing drainage channels follows the same principles as described in section 6.3.

Lining is not necessary, but good maintenance is required to secure operation at all times. The full supply level in drains should be kept below the root zone of crops.

6.5.3 Designing Drainage Systems

Surface drainage systems are designed to remove surplus water at a rate which is calculated or estimated. It is usually based on the maximum surface-run-off which may be expected after heavy rainfall.

For a small catchment area, of less than 250 hectares, this can be calculated from the formula:

$$Q = C \cdot r \cdot Fe \cdot \frac{1}{360}$$

where

Q is discharge (l/sec)

C is coefficient of runoff (see table)

r is rainfall intensity (mm/h)

Fe is area of catchment (ha)

Soil	APPROXIMATE VALUES OF C						Rock
	Sand			Clay			
	Slope of Catchment	Forest	Grass-land	Without Veg.	Forest	Grass land	
Plain	0.10	0.15	0.20	0.25	0.35	0.50	0.60
Sloped	0.15	0.22	0.30	0.40	0.55	0.65	0.70
Hills	0.25	0.30	0.40	0.60	0.77	0.80	0.80

Source: /10/

Areas out of the irrigated area may also belong to the catchment area.

The coefficient of runoff also depends on the moisture content of the soil and the rainfall intensity (if both are high, C will be high).

DRAIN CHANNEL CAPACITIES IN litres/second FOR VARIOUS CHANNEL SLOPES AND SECTIONS							
Channel Slope	Bed width (B) and water depth (D) in metres						
	B	0.10	0.15	0.20	0.25	0.30	0.40
	D	0.15	0.25	0.30	0.40	0.50	0.65
0.01%		2.5	9.3	16	33	59	121
0.02%		3.6	13	23	47	84	172
0.05%		5.6	21	36	74	133	271
0.1%		7.8	30	51	107	190	390
0.2%		11	42	71	148	266	540
0.3%		13.5	51	87	183	330	670
0.4%		15.5	59	100	212	380	765
0.5%		17	66	113	237	422	855
1.0%		24	94	160	330	595*	1210*

* Velocities greater than 1 m/s.

Channels are trapezoidal with side slopes $1 \frac{1}{2} : 1$ (horizontal:vertical) and roughness coefficient 0.035

Source: /9/

7. OPERATION OF THE SCHEME

Considerations regarding the operation of the irrigation scheme have to begin during the planning stage. Optimal operation has the aim of securing, at all times, sufficient water supply to every plant. It shall be cheap, durable, and easy. To achieve this aim, there must be technical devices in the channels and organisational provisions must be made.

7.1 The Technical Aspects of Operation

Following the considerations in the preceding chapter, a network of channels is designed which leads the water from its source to each field. (see figure on page 34).

The channels should be as impermeable as possible and have solid slopes. This is done on the one hand to reduce seepage, on the other to prevent unauthorised drawing of water. There shall be no water taken from the main and secondary channels.

In the channels some devices must be built to fulfil the following FUNCTIONS:

- division:
The flow of one channel has to be divided into two or more parts which flow into other channels.
- diversion:
from the tertiary channel into the field channel.
- water level control:
To divert the water, a certain water level has to be kept in front of the diversion device.
- Shut off:
in case no water is needed, a channel should be shut off.
- Measurement:
The flow in a channel should be known. (In order to control it, for determination of losses, and for having a base for water charges.)

These structures:

- should hinder the flow as little as possible (small necessary fall).
- should be sufficiently precise, as well as durable and stable.
- should not be expensive.
- should be unaffected by sediments and other carried materials (like branches).
- should be secured against unauthorised intervention.
- should need little maintenance care.
- should be relatively independent of the water level in the channel.

In our case, mainly WEIRS will be used, because they can fulfil the purpose of division, water level control, shut-off, measurement, and dropping the stream. For further details see Appendix E .

These considerations are quite idealistic, because it is often said that there is not a single structure in a small-scale irrigation scheme. For example, in Taiwan, there is just a single structure for every 50 hectares.

However, to secure a safe, fair, and small-loss distribution of the (in many cases scarce) water supply, the insert should be considered. This requires a few skilled users.

-- Turnout--

Each field has one turnout which diverts the water from the channel to the field-channel or, in the case of basins, directly to the field. Usually many outlets (depending on the number of fields) are needed. Therefore they should be cheap and easy to operate.

Frequently a hole is dug into the bank of the channel and refilled after usage. This method is not precise and promotes erosion.

Better suited are TAKEOUTS SOLIDLY INSTALLED into the bank, for example made from wood, which can just be opened or shut. The discharge capacity is shown below:

<u>DISCHARGE CAPACITY OF WOODEN TAKEOUTS</u>			
(litres per second)			
Inside square opening (cm)	Net head on top of the takeout		
	5 cm	7.5 cm	10 cm
7.5 x 7.5	4.0	5.1	8.4
10.0 x 10.0	6.7	10.3	14.7
15.0 x 15.0	13.3	24.0	34

Also, solidly installed SPILES can be used, for example made of bamboo. The discharge is the same as for siphons.

Both possibilities need a known water-level in the channel. Eventually the water has to be raised for the time of taking-off. This can be reached by existing weirs or by portable weirs (made of metal or wood) stuck into the slope.

Another possibility are SIPHONS made of metal (aluminium), but also for example of bamboo. (see Appendix F). They are easy to operate and do not destroy the bank. Being portable, only a small number are needed.

Discharge depends on the diameter and the pressure head (i.e. the difference in height between water-level in the channel and outlet or water-level in the field.)

<u>FLOW THROUGH SMALL SIPHONS AND SPILES</u>				
Flow in litres per second				
Diameter of siphon or spile	Pressure Head (centimetres)			
	5	10	15	20
2 cm	0.19	0.26	0.32	0.73
4 cm	0.75	1.06	1.29	1.49
6 cm	1.68	2.38	2.91	3.36
8 cm	2.99	4.23	5.18	5.98
10 cm	4.67	6.60	8.09	9.34

Inflow can also be regulated by the number of siphons used (just add it).

When irrigating furrows from special field-channels, just one siphon is used for each furrow.

The maximum amount of water which can be led to a field can, for different fields, be regulated by varying the opening of the turnout. This provides the same water level in the channel (wider opening, larger inflow).

The duration of supplying one field depends on the amount of water needed (i.e. the field water requirement).

1 mm corresponds to $10 \text{ m}^3/\text{ha}$, or $1 \text{ l}/\text{m}^2$

Multiplying this number by the area of the field, gives the amount of water, given in m^3 , received. Dividing this by the discharge of the outlet, the required time is calculated.

This shall be illustrated by continuing the example from page 30 .

EXAMPLE

The maximum irrigation requirement is in October with max $I_n = 130$ mm/month; the rotation turn is every 10 days, with an application of 50 mm each time. The soil is clay loam.

First we examine the irrigation OF FURROWS:

Field size: 0.6 hectares

$$\begin{aligned} L_m &= 150 \text{ m} && \text{length} \\ S_m &= 0.8 \text{ m} && \text{furrow spacing} \\ I &= 0.1 \% && \text{slope} \end{aligned}$$

Thus, the maximum non-erosive flow per furrow is

$$q_m = \frac{0.6}{I} = 6 \text{ l/sec (see page 53)}$$

This is, in fact, less due to furrow length, which is in maximum 470 m, and infiltration rate, which is, for clay loam, $k_f = 10$ mm/hr. (See page 20)

Thus, flow per furrow q_f is, depending on k_f , field length, and furrow spacing:

$$q_f = \frac{k_f \cdot L_m \cdot S_m}{3600} = \frac{10 \cdot 150 \cdot 0.8}{3600} = 0.35 \text{ (l/sec. furrow)}$$

The field application efficiency is $E_a = 0.5$, so with each irrigation

$$50 / 0.5 = 100 \text{ mm or } 100 \text{ l/m}^2$$

have to be applied.

The area of one furrow is $150 \cdot 0.8 = 120 \text{ m}^2$.

Thus $100 \cdot 120 = 12,000 \text{ l}$ have to be applied to each furrow, which means the application time - t_a - is:

$$t_a = \frac{12,000}{0.35} \hat{=} \sim 10 \text{ hours}$$

Irrigating 10 furrows a time, 3.5 l/sec have to be supplied to the field, which will receive water for $5 \cdot 10 = 50$ hours.

Basin Irrigation

The basin-size shall be $20 \cdot 20 = 400 \text{ m}^2$; the application is also 100 mm, which gives the necessary inflow per turn:

$$400 \cdot 100 = 40,000 \text{ l}$$

The inflow is 10 l/sec (see the table on page 46), thus the application time t_a is:

$$t_a = \frac{40,000}{10} \hat{=} 1.1 \text{ hour}$$

This calculation is quite sophisticated and shall just demonstrate the relationships. Generally, the inflow cannot be so controlled that the exact requirement is received. Also, plant water requirements are calculated based on average climate data. There might have been some unexpected rainfall, or an especially dry year. (i.e. high evapotranspiration). These facts have to be taken into account.

Generally the farmer will lead in more water than is required (not knowing the exact amount needed), i.e. as much as he can get. This can be dangerous in view of erosion, and can also lead to water-logging and outwashing of nutrients, as well as of salts, which corresponds to the necessary leaching. He can also take the share of another farmer who might be unhappy about this.

7.2 Organisation of Operation

An irrigation scheme can be technically perfect, but a functioning operation is only obtained by an appropriate and efficient organisation. There is no "ready-made" type of institution which fits every context.

The planning has to proceed from each farmer's own skill and needs. The more work that is done in self-responsibility and self-help, the less assistance is needed from outside, and the larger the interest which exists in a smooth running operation.

Also, in this manner, the ever-changing demands of the users can be adopted immediately.

The irrigation-system is built to have channels and joint fields with a certain field water requirement at distinct times, as shown in the preceding chapter. These considerations are based on a system in which each field receives water only in a certain time sequence, because, for example, the available water supply only allows this.

In the case of ample water supply, few users, and/or large channel capacities, the farmers may irrigate whenever they think that to be necessary (based on computations, plant appearance, experimental determination of actual soil-moisture content, etc.). But in most cases the available water supply will not be sufficient to allow every user the opportunity to irrigate whenever he chooses (this also presupposes large channel capacities with high capital-needs).

A schedule, the ROTATION PLAN, has to be designed to assign every user a fixed flow over a period of time in proportion to the field area. This flow must be sufficient in every case to secure plant growth, and timely as well. The design can be drawn for one channel and/or the entire network of channels. It's operation should be simple, i.e. one field after the other should get it's water. The last field on the channel begins, then the second last, and so on. When all fields on one channel are supplied, the next follows. By using this method it can be seen when one user takes water before he is permitted to do so.

Because not all fields irrigate the same crop at the same time, which means that they have a different water-requirement, the rotation-plan should be newly drawn for every turn. Actual changes in (natural) conditions, like unexpected rainfall, should be taken into consideration.

Two or more fields can be irrigated at the same time, assuming that the channel-capacity (laterals) is large enough. The 'arriving' water has to be divided at some point.

It follows that the rotation-plan contains statements about what time and at which place (field-outlet, weir, division-box, etc.) what work (open or close) has to be done. This counteracts the tendency to over-irrigate and helps to distribute the available water with little loss.

-- Difficulties --

It very often happens that the upper users take water whenever they want so that the lower users do not receive water (the so-called tail-end syndrome). In other cases, for example non-cooperatively operated schemes, the distribution structures were destroyed or not operated. It is therefore especially advisable that one user (or a group) survey the operation as well as prepare the rotation plan. This could significantly be the last (lowest) user because of his special interest. Eventually he will receive a compensation for his services, which are for the benefit of all. In no case should this 'water-master' be employed by the state or a large institution.

An ORGANISATIONAL STRUCTURE must be found for the entire scheme which:

- supervises the full process of water distribution.
- settles disputes among the users.
- represents the users to the outside, i.e. the state authorities.

Whenever possible existing institutions should take over this task, for example the farmer's cooperative.

Special rules, supervised by a special committee, will have to be made to secure the operation, with offenders punishment by some sort of penalty.

In most countries the government supervises the irrigation projects, at least the large-scale ones. Special laws or regulations may govern certain questions (rights to land and water etc.). Very often the main-channel may be financed and constructed by the government, and the rest, which are described in this booklet, is done by the farmers. In any case, operation should be in the farmers' hands.

Decisions which the farmers cannot influence, or make themselves, will cut their responsibility and can lead to deteriorating conditions (for example, inadequate maintenance). On the other hand, a (state) paid official will never have as much interest in a well-run operation as a farmer.

By the participation of every farmer, they will acquire knowledge about the relationships and also the essentials of operation. This will lead to a feeling of responsibility and confidence in their own power. The process of consciousness-raising is a primary basis for a change in their situation, politically as well as economically.

EXAMPLE: From Tanzania¹

A rather old irrigation scheme is found near Soni in the north.

An 8 km long channel, built with hoes, supplies (maximum 7.5 l/sec) to about 150 users.

The village elder is responsible for operation as well as for time schedules. Shortly before the main-irrigation period all users are called to collectively put the channel into order. (cleaning, sealing the banks, and other repair work.)

Every user has the right, as long as he cooperates, to take water out of the channels on 2 days a week. (Rare) contraventions are punished by confiscation of fowl or tools.

1. M. ATTEMS, Bauernbetriebe in tropischen Hohenlagen Ostafrikas, München, 1967, p. 74.

7.3 Maintenance

Operation without problems will only be possible when good care is taken of all channels and structures.

Maintenance means:

- cleaning the channels of silt-deposits, (sediments), weeds and brush, and animal-dug holes in the banks.
- securing (i.e. lining) the banks.
- maintaining regulating and measuring structures.
- preventing erosion.

No crops should be planted in or directly near the channels.

Maintenance should be done by the users themselves and/or controlled by the water-master.

Especially the lower users will be affected by the deficient maintenance, which is particularly necessary in the upper part.

In addition to all these measures relating to irrigation, it is necessary that preparation of the fields themselves not be neglected.

7.4 Miscellaneous

-- 24 Hour per day operation --

As regards night irrigation, the following points should be noted:

- safe water supply must be secured.
- channels must be in a good and safe condition at all times.
- the fields have to be level.
- soil must be safe against erosion.
- night irrigation is not avoidable.
- the cultural (including religious) context must allow work at night.

A full 24 hour operation is only feasible when these points are met.

Otherwise construction of a night-reservoir might become necessary, which retains the inflow (from rivers, springs) in the night and delivers it during the day. This might allow extension of irrigated fields. Suitable topography is a prerequisite.

-- Water Charges --

In some projects water-charges have to be paid to cover expenses. They may depend on the yield (for example, one sack per hectare) and/or the cultivated area.

In case the charge is paid according to the amount of water used, a very efficient use of the available supply is possible, as experiences show. But this makes sufficient and always functioning measuring-devices necessary, as well as trained and independent personnel. This possibility appears to be of little use for small-scale irrigation.

-- Using the Surplus Water of Large-Scale Projects --

In planning large-scale irrigation schemes little thought is usually given to the use of the drainage (or surplus) water. Small-scale schemes nearby may take advantage of this unused water by irrigating solely dependent on it or by using it as additional flow. Drainage water in many cases is tolerable to most plants.

In any case, because of the danger of salinisation, precise and regular analyses of the soil and water will have to be made. This could be done by the large-scale project.

Also taken into account should be:

- the available water supply is unknown in its distribution over the year.
- there will be no claim on it, unless secured.
- often the use of pumps will become necessary (if the drainage channels are in depressions).

7.5. EXAMPLE: Fair Distribution In Bali 1)

The Balinese evolved what is probably the most socially sophisticated system of village irrigation anywhere in the world. Every owner of land in a particular ecological unit-watered by the same stream or canal - belongs to a common organisation, the 'sebak', which maintains the system and controls water use. It meets once every Balinese month of 35 days, and has its own system of law called 'awig-awig'. Every landowner has to provide free labour one day a month for repair and maintenance - the more land he owns, the more labour he must provide or pay for.

The 'sebak' decides democratically on planting times - simultaneous planting is preferred to keep pests and diseases down, but if water is insufficient for everyone's land to be irrigated at the same time, the 'sebak' works out a complicated planting and cropping rota to stagger the demand for water. Though landholding is far from equal, water is distributed with scrupulous fairness. Its supply is regulated into each parcel of land by a length of coconut tree trunk spanning the inlet. For every one 'tenah' of land (0,35 hectares) he owns, each 'sebak' member has a right to one 'tektek' of water. A 'tektek' is a gap four fingers wide cut into the coconut trunk. Anyone who attempts to cheat the system, and take more water than he is entitled to, can be tried by the 'sebak' meeting and fined heavily.

The technology of the system is as primitive as its organisation is advanced. The weirs are just piles of stones in the river. The coconut trunk inlet regulates only the width of water, not the height. In the heavy rains of November and December flash floods often sweep away weirs and break down the bundhs between the fields. Farmers usually delay planting for as much as two month, until water supply is more even. That delay costs an extra crop of rice in most areas.

In Bali the small-scale irrigation effort has gone into upgrading the village systems - building permanent, solid weirs and primary canals and providing control gates that can regulate the supply of water. Areas that have already been upgraded have seen an increase in cropping intensity of anything up to 80 per cent.

In all the small-scale irrigation projects labour-intensive methods are used. Excavation, even of lang tunnels, is by pick and shovel; waste is carried away in straw baskets on the head. Masonry is used instead of concrete; and the stones are collected and broken up on or near the site. One Balinese weir was getting the final touches when I saw it - workers were handsetting thousands of tiny pebbles into mortar to provide an attractive finish.

1) taken from: HARRISON, P.: "Getting enough to eat in Indonesia", in: New Scientist, 17.11.1977, p.419

8. The Financial Aspect

The consideration of costs and possible benefits is of paramount importance, but they are difficult to estimate.

It can be said that irrigation is expensive in any case, and this also applies to small-scale irrigation. The costs have to be covered by higher or safer yields.

There are several reasons to establish a small-scale irrigation scheme:

- To secure subsistence.
When there is no experience of irrigation, the implementation of it seems to make little sense, because there is no private capital for financing it. Possible risk can lead to a deterioration of the farmer's position. It should be taken into consideration whether traditional cultivation practices can be improved.
- To secure or increase the yield/income and food-supply through (additional) irrigation.
In this case the costs have to be compared with the benefits through irrigation.
It also has to be considered that without irrigation an increase of yield is possible using improved seed-varieties, fertiliser, etc.. This also applies to semiarid and arid areas.

8.1 Costs

The costs of an irrigation scheme can be detailed:

- investment costs. Costs which are necessary for construction.
- operation costs. Costs which arise from operation.
- indirect ensuing costs. Costs which secure the yield.

The term 'costs' includes costs for material, labour, energy, and capital. By self-help work the wage part can be kept low.

-- Investment Costs --

- Costs for obtaining water.
- Costs for the entire channel-network. This includes digging, lining, and regulating structures.
- Costs for levelling the fields. This can be done by self-help. Simple tools must also be bought and/or constructed.

These may eventually include:

- Costs for the construction of dams, roads, etc.
- Costs for land amalgamation.

It is not possible to give generally valid quantitative or relative values for the costs.

Costs for constructing a dam (reservoir) can be considerable. The use of heavy machinery might be considered.

Water can be obtained by gravity supply or by pumping (see Section 6.2).

GRAVITY SUPPLY will always be cheaper because, despite its high initial costs, its long life with relatively low running costs gives it a great advantage in the long run. An additional advantage is that their costs contain a larger proportion of local elements than the capital cost of a PUMPING SYSTEM, most of whose parts are likely to be imported.

Pumping systems also require more careful control and management than gravity systems.

Costs for water-lifting devices depend on the type used. It has to be considered that operating costs (fuel, electricity, fodder) can be very expensive in the long term. Traditional devices are cheap in initial costs but their performance is low and they might become expensive compared with their attainable efficiency. A draught-animal uses only a little less fodder than it irrigates.

Levelling works can be extensive and therefore expensive. In a survey of Indian projects, the levelling-work share of total costs was about 50%. For this reason, the size and shape of the field should be well-suited to the topography to minimize the necessary earth-movement. This particularly applies to small-scale irrigation.

-- Operating Costs --

- Costs for energy for pumps (diesel, electric) will considerably rise in the near future. Pumps can also be operated by solar or wind energy. (see Appendix G for formulas to calculate the energy consumption of pumps).
- Costs for wages. In case for example, wage labourers clean the channels.
- Costs for maintenance work.
- Possible water-charges, either to a landlord or an irrigation authority (government). (see also page 6).
- Tenure.

-- Indirectly Ensuing Costs --

- Costs for:

- (necessary) artificial fertiliser.
- improved seed varieties.
- plant protection.

Costs may also arise when marketing the newly or additionally produced goods. Examples include (larger) godowns for storage, additional processing of the crops, and transport, etc..

8.2 Yields

The benefits of irrigation depend on the selection of the cultivated crops.

With a high investment cost, cultivation/irrigation of the more lucrative or productive crops seems advisable.

The choice depends as well on the needs of the users (securing of food supply), the available water supply, or the marketing possibilities.

In some cases cultivation of certain crops (rice for example) is promoted by government (price) policies.

The profitability of certain crops closely depends on costs of marketing (transport).

Storage might become necessary.

<u>POSSIBLE YIELDS OF IMPORTANT CULTIVATED CROPS</u>		
<u>Crop</u>	<u>Possible yield un-irrigated</u>	<u>Possible yield irrigated</u>
in 100 kg/ha.....	
Rice (paddy)	13- 62	60- 100
Wheat	3- 41	30- 60
Maize	3- 43	40- 200
Sorghum	2- 39	50- 200
Potatoes	50- 290	200- 400
Cabbage	40- 670	600-1000
Tomatoes	30-1420	500-1500
Peas	3- 32	10- 45
Bananas	40- 340	300- 500
Cotton	1- 12	15- 35
Citrus	350- 500	400- 600

(following: BLANCKENBURG/CREMER, 1967)

8.3 Financing

After estimating costs and benefits (the calculation always contains assumptions and risks!) it has to be determined whether the project is profitable and/or financially.

The investment costs must be spread over a number of years. This depends particularly on the durability of the construction (for example, concrete-lined channels are expensive but will last longer than earth channels). Pumps last for 10 to 20 years.

The annual interest rate depends on where and under what conditions the needed loans are taken. Annual costs are then related to a point of time in the present or future and compared with estimated benefits. (For some formulas see Appendix H).

The difference between costs and benefits is the CASH FLOW, and it will be negative in the first years of operation.

One should also consider possible development without irrigation by improved cultivation techniques.

Production cannot grow faster than the financial possibilities of the farmers. Because their potential of self-financing is quite low, they are dependent on credit (given by the state).

8.4 The Role of Co-operatives and Government

Financial borrowing may lead to dependence on (private) money-lenders. In Nepal, for example, about 85% of all borrowing is taken from private money-lenders, for a rate of interest ranging from 10 to 50%. Founding CO-OPERATIVES is a possibility. All users should be members. In addition to lending money it can also serve to promote input-supply and marketing.

As much as possible, existing co-operatives should be used because the foundation of new ones always is connected with problems. They should be founded by the farmers themselves and not by the government.

Special care should be taken when considering the possible participation of rich farmers in the co-operative. They might use the cheap lending rates offered by the co-operative to finance their own agriculture and not return the saved-up accumulation values to the smallholders.

Besides, all the latter are disadvantageded due to their inability to give financial securities which may be a prerequisite for receiving credit. In this way a co-operative could serve to stimulate further capitalist penetration of agriculture and accelerate the process of peasant pauperisation.

The GOVERNMENT can take several precautions to promote smallholder farming, among which are:

- Land reform, transferring the smallholders from tenants to owners of the cultivated land.
- Laws protecting the tenants, especially smallholders, in order to reduce their dependence on the landlords.
- Land amalgamation and prohibition of further sub-division of fields smaller than a certain area (1 to 5 hectares). By splintering into a vast number of small plots, planning and construction for irrigation is greatly hampered.
- Financial support of the smallholders by offering them convenient credit; or assistance with inputs and marketing.

These measures have to be enacted in a way that they directly reach the smallholders. They must contribute to improving their possibilities. This group represents, after all, the majority of the rural population.

 It is obvious that enacting these measures will result in considerable political problems--but only by fulfilling them can the long-term success of small-scale irrigation be secured.

RECOMMENDED LITERATURE

1. BOOHER, L.J., "Surface Irrigation." FAO (Rome), 1974.
 2. FOOD AND AGRICULTURAL ORGANISATION, (Rome). Irrigation and Drainage Papers:
 - No. 1. Irrigation Practice and Water Management, 1971.
 - No. 3. Design Criteria for Basin Irrigation Systems, 1971.
 - No.12. Farm Water Management Seminar (Manila), 1972.
 - No.24. Crop Water Requirements, 1977.
 - No.30. Self-Help Wells, 1977.
 3. HAGAN; HAISE and WESTMINSTER; "Irrigation of Agricultural Lands." (Madison, Wisconsin), 1967.
 4. "Handbuch der Landwirtschaft und Ernährung in den Entwicklungsländern." Band 1 und 2 (Stuttgart), 1976.
 5. ISRAELSEN, O.W.; and HANSEN, V.E., "Irrigation Principles and Practices." (New York, London), 1962.
 6. KREEB, K., "Ökologische Grundlagen der Bewässerungskulturen in den Subtropen." (Stuttgart), 1964.
 7. RUTHENBERG, H., "Farming systems in the Tropics." (Oxford), 1971.
 8. SCHEFFER; and SCHACHTSCHABEL, "Lehrbuch der Bodenkunde." (Stuttgart), 1976.
 9. STERN, P., "Small Scale Irrigation." Intermediate Technology Development Group, (London, Bet Dagan, Ottawa), 1979.
 10. WITHERS; B.; VIPOND, S; and LECHER, K., "Bewässerung." (Berlin, Hamburg), 1978.
- English version: "Irrigation--Design and Practice." (London), 1974.

APPENDICES

- A. Map-Making Using a Plane Table
- B. Estimating Small Stream Water Flow
- C. Field Method for Identifying Soil Texture
- D. Texture Guide for Readily available Soil
Moisture Based on Feel or Appearance of Soil
- E. Weirs
- F. Siphon Tube
- G. Energy Consumption of Pumps
- H. Formulas Used in Financial Analysis
- I. Conversion Factors

Appendix A

MAP-MAKING USING A PLANE TABLE

Instructions are given here for making serviceable maps using a plane table. Such maps are valuable for irrigation, drainage and village layout plans.

Before aerial photography, most topographical maps were made by the use of plane tables.

Tools and Materials

Plane table (see preceding entry)
Paper
Pencil
Ruler
Pins
Tape measure (optional)
Spirit level (optional)

Measuring Pace

If no long tape measure is available, the first step for a map maker is to measure his pace: A 30-meter (100-foot) distance should be measured out on level ground. If only a 30cm (12") ruler is available, this can be used to mark out a meter (3' or 4') on a stick; this stick in turn can be used to measure the 30m (100').

Being careful to walk normally, the map maker then counts the number of paces he takes in walking the 30m (100') interval. Simple division will then give the average length of a pace.

Map Scale

The next step is to decide on a scale for the map. This is determined by judging the longest distance to be mapped and the size of the map desired. The map does not have to be made on a single sheet of paper; it can be pieced together from several sheets when it is completed. For example: if you want a map 80cm (2 1/2') long of an area whose longest dimension is 800 meters (1/2 mile or 2540 feet), then a scale of 1 meter to 1cm (100 feet to the inch) would be convenient.

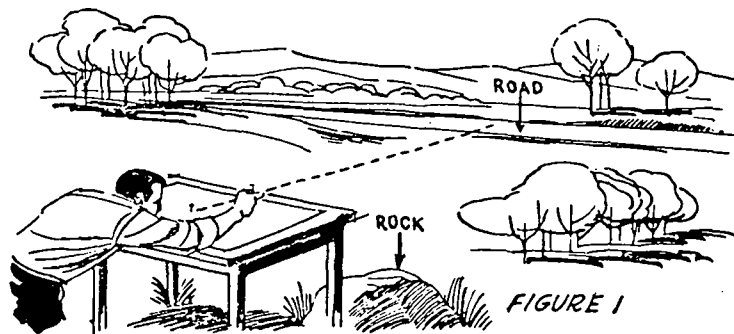

Map Making

1. Place paper on the plane table and orient the plane table on or near some principal feature of the area; for example, a path, road, creek or tree.
2. Place a pin vertically in the spot on the map to locate this feature.
3. Make the plane table level; for example, by using a spirit level. If a spirit level is not available, you can level the table by using anything which rolls easily.
4. Rotate the table to a proper orientation, so that the map will be made in the desired direction.

5. Sight along the first pin to another principal feature which is visible from the table location (a bend in a road, a hill or any feature which will tie the map together, moving the second pin into the line of sight (see Figure 1). A ruler can be used for this purpose if it has a sighting edge; a sighting edge can be made by sticking a couple of pins into the ruler.
6. Draw a line in the direction defined by the two pins.
7. Measure the distance to the feature observed either by pacing or with a tape measure.
8. Scale this distance along the line drawn on the map, starting at the first pin.

9. Repeat this process for other principal features which can be seen from this location (see Figure 2).

10. When this has been done, move the table to one of the points just plotted, selecting one which will enable you to move over the area conveniently. For example, follow a lane or creek or some feature which ties things together.

11. Set the plane table over this point and re-orient the table by putting pins in the map at the present and previous locations. This procedure locates the line joining the two locations on the map in the same direction as the line exists in nature, making it possible to go on to the next step with the map oriented properly.

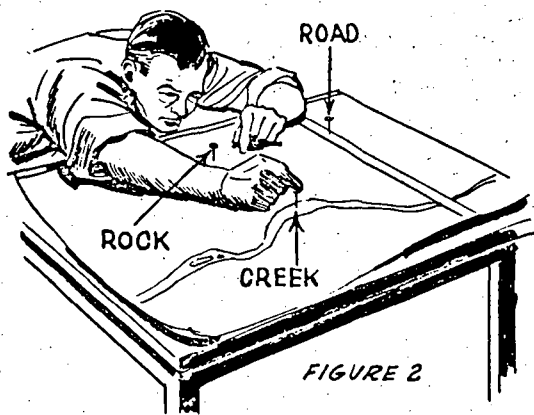

12. From this new location, map in the principal features which can be conveniently sighted.

In this way the entire region to be mapped may be covered in a systematic way. If gaps appear or if more detail is needed, go back and set up over some mapped feature, reorient the map by sighting on a second feature, and proceed to map in the detail.

To map features which are not going to be used as plane table locations in the mapping process, draw a line in the direction of each feature from two plane-table locations. The intersection of these two lines corresponding to a single feature locates the feature on the map. This avoids the need for measuring distances. Note, however, that the distances between plane-table locations must be measured.

Relative Elevations

If a spirit level is available, it is possible to level the plane table accurately and, using a ruler or other sighting device, plot relative elevations on the map.

A stick about 2 or 3 meters (6' or 8') long should be marked off in centimeters (inches). A person holding the stick vertically can, by moving his finger up or down, identify to the person sighting the distance up from the ground through which the line of sight passes.

Taken from: VITA Village Technology Handbook, 1975

Appendix B

ESTIMATING SMALL STREAM WATER FLOW

A rough but very rapid method of estimating water flow in small streams is given here. In looking for water sources for drinking, irrigation or power generation, one should survey all the streams available.

If sources are needed for use over a long period, it is necessary to collect information throughout the year to determine flow changes--especially high and low flows. The number of streams that must be used and the flow variations are important factors in determining the necessary facilities for utilizing the water.

The following equation will help you to measure flow quickly: $Q = K \times A \times V$, where:

Q (Quantity) = flow in liters per minute

A (Area) = cross-section of stream, perpendicular to flow, in square meters

V (Velocity) = stream velocity, meters per minute

K (Constant) = a corrected conversion factor. This is used because surface flow is normally faster than average flow. For normal stages use $K = 850$; for flood stages use $K = 900$ to 950 .

Tools and Materials

Timing device, preferably watch with second hand

Float (see below)

Measuring tape

Stick for measuring depth



To Find A (Area) of a Cross-Section

The stream will probably have different depths along its length so select a place where the depth of the stream is average.

1. Take a measuring stick and place it upright in the water about 50cm from the bank.
2. Note the depth of water.
3. Move the stick 1 meter from the bank in a line directly across the stream.
4. Note the depth.
5. Move the stick 1.5 meters from the bank, note the depth, and continue moving it at 50cm intervals until you cross the stream.

Note the depth each time you place the stick upright in the stream. Draw a grid, like the one in Figure 2, and mark the varying depths on it so that a cross-section of the stream is shown. A scale of 1cm to 10cm is often used for such grids. By counting the grid squares and fractions of squares, the area of the water can be estimated. For example, the grid shown here has a little less than 4 square meters of water.

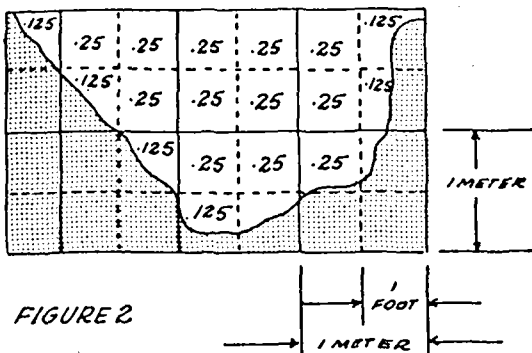

To Find V (Velocity)

Put a float in the stream and measure the distance of travel in one minute (or fraction of a minute, if necessary.) The width of the stream should be as constant as possible and free of rapids, where the velocity is being measured.

A light surface float, such as a chip, will often change course because of wind or surface currents. A weighted float which sits upright in the water will not change course so easily. A lightweight tube or tin can, partly filled with water or gravel so that it floats upright with only a small part showing above water, will not change course so easily and makes a better float for measuring.

Measuring Wide Streams

For a wide, irregular stream, it is better to divide the stream into 2 or 3 meter sections and measure the area and velocity of each. Q is then calculated for each section and the Qs added together to give a total flow.

Example (see Figure 2):

Cross section is 4 square meters

Velocity of float = 6 meters traveled in 1/2 minute

Stream flow is normal

$$Q = 850 \times 4 \times \frac{6 \text{ meters}}{.5 \text{ minute}}$$

$$Q = 40,800 \text{ liters per minute}$$

or

$$680 \text{ liters per second}$$

Taken from : VITA - Village Technology Handbook, 1975

Appendix C

FIELD METHOD FOR IDENTIFYING SOIL TEXTURE

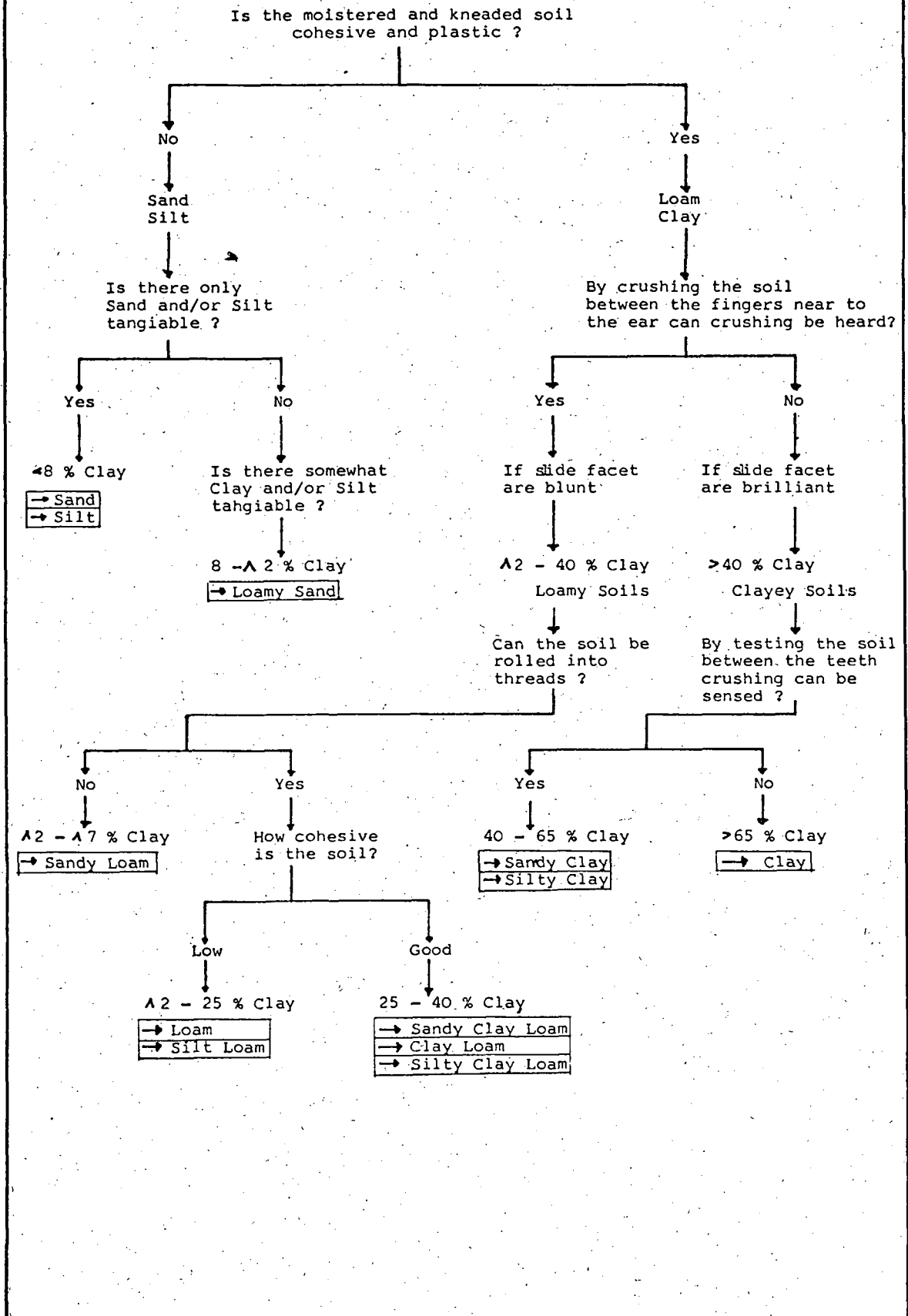

Appendix D

TEXTURE GUIDE FOR READILY AVAILABLE SOIL MOISTURE
BASED ON FEEL OR APPEARANCE OF SOIL

Percent available moisture remaining	Loamy sands and sandy loams (coarse textured)	Very fine sandy loam and silt loam (medium textured)	Silty clay loams and clay loams (fine textured)
0-25	Dry, loose, flows through fingers	Powdery, sometimes slightly crusted, but easily broken down into a powdery condition	Hard, backed, cracked; difficult to break down into powdery condition
25-50	Appears to be dry, will not form a ball with pressure	Somewhat crumbly, but holds together with pressure	Somewhat pliable, balls under pressure
50-75	Tends to ball under pressure, but seldom holds together when bounced in hand	Forms a ball, somewhat plastic, sticks slightly with pressure	Forms a ball, ribbons out between thumb and forefinger, has a slick feeling
75-100	Forms a weak ball, breaks easily when bounced in hand, will not slick	Forms a very pliable ball, slicks readily	Easily ribbons out between thumb and forefinger, has a slick feeling
100 (at FC)	Upon squeezing, no free water appears on soil, but wet outline of ball is left on hand; soil sticks to thumb when rolled between thumb and forefinger	Same as sandy loam	Same as sandy loam
Saturated	Free water appears on soil when squeezed	Same as sandy loam	Same as sandy loam

Source : PILLSBURY, A.F. : " Sprinkler Irrigation"
 FAO, (Rome) 1968.

Appendix EWEIRS

Weirs are simple to construct, reliable, and quite precise. They can be built out of wood and/or metal.

Discharge Q is a function of length of crest and head on crest. It can be calculated by a formula or taken from a diagram or table.

The weir has to be constructed perpendicular to the direction of flow. Due to the draw-down effect in front of the weir-crest, the gauge post must be installed $4 \cdot h$ (h = maximum head on crest) upstream of the weir (see figure).

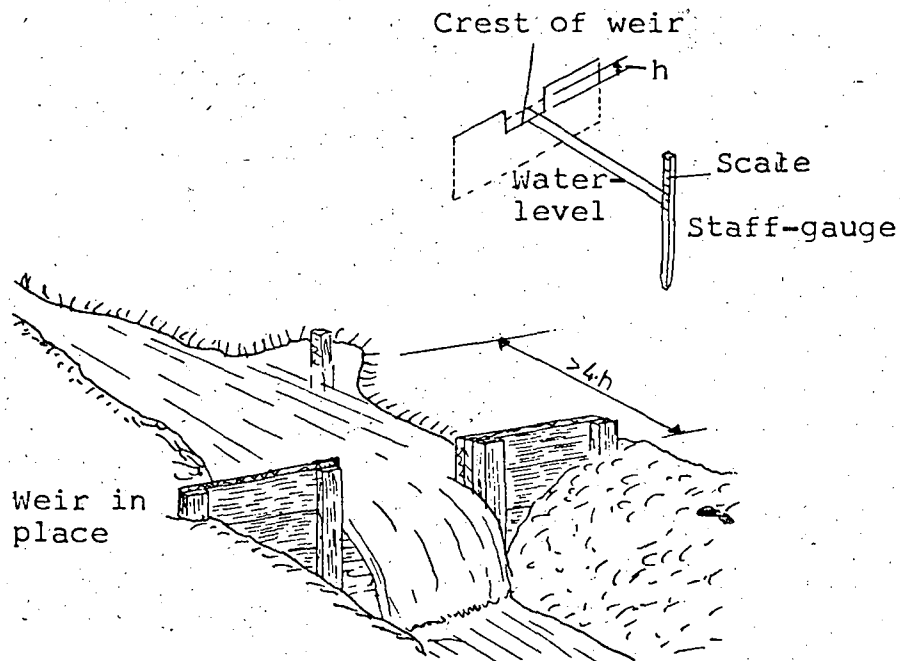

Diagram of rectangular weir

The approach has to be uniform over some distance; the velocity of approach should be $v_a < 15$ cm/s. It is possible that the channel has to be broadened upstream from the weir to reduce v_a (see figure).

The gauge staff should be at the edge of the channel. In front of the weir and gauge staff no silting should occur.

To prevent a sharp crest a 2 mm metal-sheet can be used.

The weir can also be used as a drop-structure. In any case the channel has to be lined with rocks or bricks some short distance downstream from the weir to reduce the danger of erosion.

We discuss three different popular types of constructed weir notches:

-- Rectangular Weir --

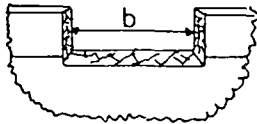

A

The rectangular weir has a horizontal crest with vertical sides. The difference between the bottom of the channel and the weir crest should be twice the maximum head of the crest.

$$Q = 1.838 \cdot (b - 0.2 \cdot h) \cdot h^{1.5} \quad (\text{m}^3/\text{sec})$$

where: b = length of crest (m)

h = head on crest (m)

Head of Crest h (m)	Length of Crest b (m)					
	0.30	0.40	0.50	0.75	1.00	1.50
0.015	0.0010	0.0013	0.0017	0.0025	0.0034	0.0051
0.030	0.0028	0.0038	0.0047	0.0071	0.0095	0.0143
0.060	0.0078	0.0105	0.0132	0.0199	0.0267	0.0402
0.090	0.0140	0.0190	0.0239	0.0363	0.0487	0.0736
0.120	0.0211	0.0287	0.0364	0.0555	0.0746	0.1128
0.15	0.0288	0.0395	0.0502	0.0769	0.1036	0.1570
0.18		0.0511	0.0651	0.1002	0.1353	0.2055
0.24			0.0977	0.1517	0.2058	0.3139
0.30				0.2084	0.2804	0.4350
0.42					0.4584	0.7086
0.60						1.1791

($1 \text{ m}^3/\text{s} = 1000 \text{ l/s}$)

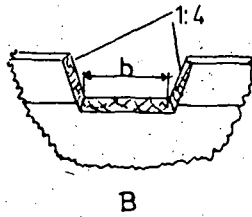
-- Cipoletti Weir --

The slope of the sides is 1:4 (horizontal to vertical).
It is comparable to the rectangular weir.

$$Q = 1.86 \cdot b \cdot h^{1.5} \quad (\text{m}^3/\text{s})$$

DISCHARGE (m ³ /s) FOR A STANDARD CIPOLETTI WEIR						
Head of Crest h(m)	Length of Crest					
	0.30	0.40	0.50	0.75	1.00	1.50
0.015	0.0010	0.0014	0.0017	0.0026	0.0034	0.0051
0.030	0.0029	0.0039	0.0048	0.0072	0.0097	0.0145
0.060	0.0082	0.0109	0.0137	0.0205	0.0273	0.0410
0.090	0.0151	0.0201	0.0251	0.0376	0.0502	0.0753
0.120	0.0232	0.0309	0.0386	0.0580	0.0773	0.1159
0.15	0.0324	0.0432	0.0540	0.0810	0.1080	0.1620
0.18		0.0568	0.0710	0.1065	0.1420	0.2129
0.24			0.1093	0.1639	0.2186	0.3278
0.30				0.2291	0.3054	0.4582
0.42					0.5060	0.7590
0.60						1.2959

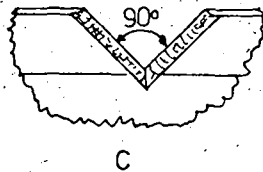
-- V- Notch Weir --

The axis of this weir is in the middle of the channel. Both sides have an angle of 45° to the vertical.

This weir is especially suitable for the measurement of small discharges.

$$Q = 1.368 \cdot h^{2.5} \text{ (l/s)}$$

where: h = head of crest in middle of weir (cm).

h (cm)	Q (l/s)	h (cm)	Q (l/s)
5	0.8	11	5.5
6	1.1	12	6.8
7	1.7	13	8.3
8	2.5	14	10.0
9	3.3	15	11.9
10	4.3	16	14.0

The V- Notch weir can easily be built in small channels. In small earthen channels a steel sheet can be pressed into the channel bed. (see figure)

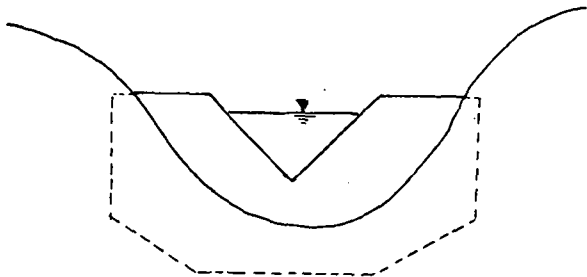

In the lined channel the weir-blade can be inserted into previously made slots. In this way the channel can also be totally shut-off.

Different weir-gates can also be inserted into a wooden check/weir-structure. (see the figure on the following page)

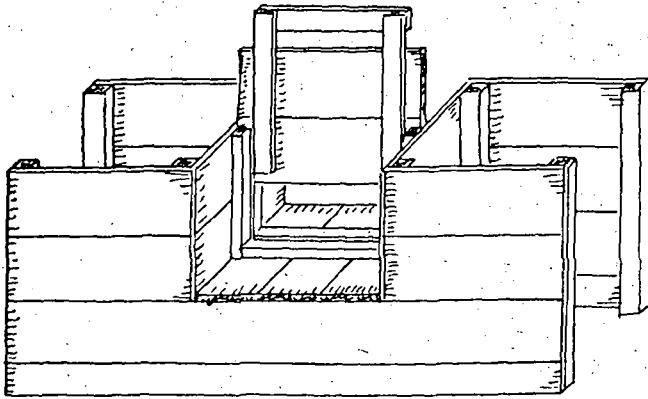

Standard double-wing wooden check gate
(U.S.D.A. Farmers Bul. 1243)

This structure can be used to raise the water level in front of an outlet in order to measure the discharge.

By placing a sharp-crested blade downstream from a Cipoletti weir and perpendicular to it, the overflow can be diverted into two shares. This combines the three functions: check, measurement, and division. It is especially important to insure: a long approach, an avoiding of silting, and sharp crests.

Appendix F

SIPHON TUBE

The metal siphon tube described here can be used for irrigation (see Figure 1). It can be easily made and repaired by tinsmiths. A siphon can also be made from a piece of rubber hose or by bending a piece of plastic tube.

Tools and Materials

Galvanized sheet metal

Tinsmith tools: solder, tinsnips, hammers, anvil

Construction details are given in Figure 2.

The purpose of this siphon tube is to carry water out of a ditch without cutting a hole in the ditch bank. In many soils a small hole cut in the ditch bank soon becomes a large hole because of erosion. Imported plastic siphons

are often expensive, easily broken and usually impossible for local people to repair.

There are several good ways to start a siphon tube. The simplest way is to put the tube in the ditch until it fills with water. Holding one hand over the end of the tube, so that air cannot get in, lift the tube out and place it as shown in Figure 1. Be sure the other end of the tube does not come out of the water while placing the tube. When the tube is in place, remove the hand and the water will begin to flow. The end of the tube outside the ditch must be lower than the level of the water in the ditch.

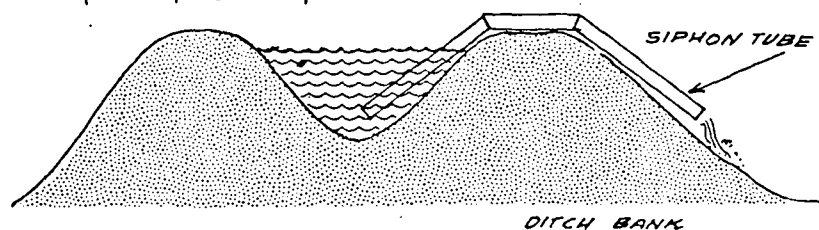

FIGURE 1

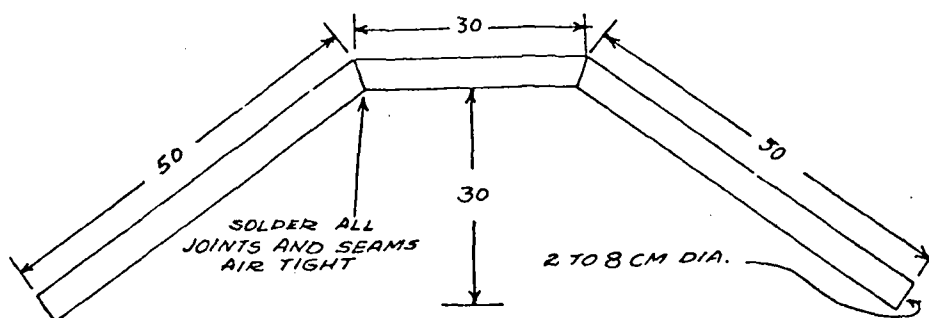

FIGURE 2

Taken from : VITA - Village Technology Handbook, 1975

Appendix GENERGY CONSUMPTION OF PUMPS¹

1.) Calculating the lift:

a.) Measurement of vertical difference in elevation
between water level and pump = 4.0 m

b.) Friction losses in the draft tube = 1.0 m

Total Suction head = 5.0 m

2.) Efficiency on pump barrel (Ni, given in PS):

$$Ni = \frac{\text{lifted quantity (m}^3/\text{h)} \cdot \text{lift H (m)}}{2.7 \cdot \text{pump efficiency (\%)}}$$

Example:

$$Q = 40 \text{ m}^3/\text{h}$$

$$H = 5 \text{ m}$$

$$\text{Efficiency} = 60\%$$

$$Ni = \frac{40.0 \cdot 5.0}{2.7 \cdot 60} = 1.25 \text{ PS}$$

3.) Motor Capacity (Ne, given in PS):

$$Ne = 1.2 \cdot Ni$$

Example:

$$Ne = 1.2 \cdot 1.25 = 1.5 \text{ PS}$$

4.) Energy consumption.

a.) Electricity consumption is kWh = $\frac{Ni}{1.36} \cdot 1 \text{ h}$

Motor efficiency 84%

Example:

$$\text{Electricity consumption} = \frac{1.25}{1.36 \cdot 0.84} \cdot 1 = 1.1 \text{ kWh}$$

1.) PERROT, Faustzahlen für den Berechnungspraktiker,
Calw, 1977

b.) Diesel-fuel consumption (be), given in g/PS h
(grams per horse-power and hour):

roughly be = 200 g/PS • h

1 l Diesel $\hat{=}$ 880 grams.

Example:

Diesel fuel consumption =

1.25 • 200 = 250 g/h

$\hat{=}$ 0.28 l/h

All these calculations are based on well-maintained machines.

Appendix HFormulas Used in Financial Analysis1. Future Amount of a Present Value (Compounding)

$$A = P \cdot (1 + i)^n$$

where: A = amount of future value

P = present value

i = interest rate per conversion period

n = number of years

The factor $(1 + i)^n$ is termed single payment compound amount.

2. Present Value of a Future Amount (Discounting)

The following formula is used in finding the present value of any amount which is to be made (n) years from now, assuming that money compounds annually at a given rate of interest :

$$P = A \cdot (1 + i)^{-n} = \frac{A}{(1 + i)^n}$$

where: P = present value

A = amount of future value

i = discount rate

n = number of years

$\frac{1}{(1 + i)^n}$ is the present worth factor

3. Future Value of Annuity

The formula used to determine the lump sum value of a series of equal yearly payments (called an annuity) at the time of the last payment is given below:

$$A = R \cdot \frac{(1 + i)^n - 1}{i}$$

where: A = the lump sum to which (n) annual payments accumulate at the interest rate (i)

R = end-of-year payments in a uniform series continuing for the coming (n) years

i = the annual rate of interest

n = the number of annual payments

$\frac{(1 + i)^n - 1}{i}$ is called the uniform annual compound amount factor

4. Present Value of an Annuity

The present value of the lump sum value of a series of equal yearly payments (given under 3. above) can be found by using the formula:

$$P = R \frac{(1 + i)^n - 1}{i \cdot (1 + i)^n}$$

where: P = the present value of the lump sum to which (n) annual payments accumulate

R = the annual payment

i = the annual interest rate

n = the number of annual payments

Appendix I

CONVERSION FACTORS

Metric and British/United States units of measurement

	<i>Metric</i>	<i>British/United States</i>
Length		
1 millimetre		= 0.039 inch
1 centimetre		= 0.3937 inch
1 metre	= 100 centimetres	= 39.37 inches = 3.2808 feet
1 kilometre	= 1 000 metres	= 0.6214 mile
1 inch	= 2.54 centimetres	
1 foot	= 0.3048 metre	
1 mile	= 1.609 kilometres	
Area		
1 square centimetre		= 0.155 square inch
1 square metre		= 10.764 square feet
1 square kilometre	= 100 hectares	= 0.3861 square mile
1 hectare	= 10 000 square metres	= 107 640 square feet = 2.471 acres
1 square inch	= 6.452 square centimetres	
1 square foot	= 0.0929 square metre	
1 acre	= 0.4047 hectare	= 43 560 square feet
1 square mile	= 258.99 hectares = 2.59 square kilometres	= 640 acres
Volume		
1 cubic centimetre		= 0.061 cubic inch
1 cubic metre	= 1 000 litres	= 35.314 cubic feet = 1.308 cubic yards
1 litre		= 0.0353 cubic foot = 0.2642 U.S. gallon = 0.2201 imperial gallon
1 cubic inch	= 16.39 cubic centimetres	
1 cubic foot	= 0.0283 cubic metre = 28.32 litres	= 7.48 U.S. gallons = 6.23 imperial gallons
1 cubic yard	= 0.7645 cubic metre	
1 U.S. gallon	= 3.783 litres	= 0.833 imperial gallon
1 imperial gallon	= 4.5460 litres	= 1.201 U.S. gallons
1 acre-inch	= 102.8 cubic metres	= 3 630 cubic feet
1 acre-foot	= 1 233.5 cubic metres	= 43 560 cubic feet
Rates of flow		
1 cubic metre per second		= 35.314 cubic feet per second
1 cubic metre per hour	= 0.278 litre per second	= 4.403 U.S. gallons per minute = 3.668 imperial gallons per minute
1 litre per second	= 3.6 cubic metres per hour	= 0.0353 cubic feet per second = 15.852 U.S. gallons per minute = 13.206 imperial gallons per minute
1 cubic foot per second	= 0.0283 cubic metre per second = 28.32 litres per second	= 448.8 U.S. gallons per minute = 373.8 imperial gallons per minute = 1 acre-inch per hour (approximately) = 2 acre-feet per day (approximately)
1 U.S. gallon per minute	= 0.06309 litre per second	
1 imperial gallon per minute	= 0.07573 litre per second	
Pressure		
1 atmosphere		= 14.7 pounds per square inch
1 pound per square inch	= 0.068 atmosphere	