

Library
IRC International Water
and Sanitation Centre
Tel.: +31 70 30 669 80
Fax: +31 70 35 699 64

R&D Report
on
Rural Sanitation

RESEARCH REPORT ON RURAL SANITATION

LIBRARY IRC
PO Box 93190, 2509 AD THE HAGUE
Tel.: +31 70 30 689 80
Fax: +31 70 35 899 64
BARCODE: 14025
LO: 320 93RD

CONTENTS

1. Low Cost Super Structure for Twin Pit Pour Flush Latrine	1
2. Red Clay Glazed Squatting Pan, Trap and Foot Rest	3
3. Estimate of Split Bamboo Grid Super Structure	4
4. Estimate for Mud Block Super Structure	8
5. Estimate of Cement Treated Gunny Bag Super Structure for Low Cost Latrine	10
6. Low Cost Semi-Flush Ferro Cement Latrine	14
7. Detailed Breakup Cost of Ferro Cement Latrine	21

RURAL SANITATION Research & Development Work

The following developments have taken place under the Research & Development Programme on Rural Sanitation.

LOW COST SUPER STRUCTURE FOR TWIN PIT POUR FLUSH LATRINE.

In order to give relief to poor household in rural areas in respect of their contribution towards construction of sanitation facilities, efforts was made to utilise local materials and skills. Following techniques were developed by the Centre for Development of Rural Technology at Institute of Engineering and Rural Technology, Allahabad.

Mud Plastered Split Bamboo Grid Walls.

One inch dia bamboo was split lengthwise and a grid was made using the split lengths and erected vertically in place of walls. Thereafter, well prepared

mud mortar was used to plaster the grid from both sides and allowed to dry. The roof was made of empty cement bags (gunny bag) spread over a bamboo grid projecting (8" to 10") on each side from the walls. Cement mortar was used to paint the roof on both the sides.

The door was also made in the same manner as the roof.

Compressed Mud Block Walls.

Manually operated Mud Block Making Machine was used to prepare Compressed Mud Blocks, as per the prescribed techniques. Four per cent cement by weight was used to give sufficient structural strength. The sub-structure was made of usual baked bricks and the superstructure was made of mud blocks. The roof and the door were made from cement treated gunny bags supported on split bamboo frame.

Both the above techniques have reduced the cost of the super structure (brick masonry) from about Rs. One thousand six hundred (Rs.1,600/-) to Rs. Five hundred only (Rs.500/-).

The expected life will be at least 5 to 7 years and with proper maintenance it can be further increased.

Cement Treated Gunny Bag Superstructure.

By using locally available materials like used gunny bags, bamboo and cement mortar (in 1 : 1 ratio), the superstructure can be constructed. Roof of the structure is supported by four pillars (these pillars can be of bamboo of 3 inches diameter). The frame work of roof is also prepared with bamboo, steel strips and nails. Nails can be used for preparation of joints. The structure is then covered by Jute (Gunny Bag). The jute gets sagged by the application of sand cement mortar. In order to reduce it, bamboo wedges are fixed and wire mesh of 16 gauge is made to strengthen the structure

RED CLAY GLAZED SQUATTING PAN, TRAP AND FOOT REST.

Continued and intensive efforts were made to develop this technique, for the first time in the country (to the best of our knowledge), at the Red Clay Pottery Unit of Gohri Growth Centre of IERT, Allahabad. Special moulds were developed to produce the pan, trap and foot rest from pottery clay. After baking these items in a specially designed and constructed kiln, a locally prepared chemical solution was applied on the interior surface of pan and trap and the exterior of the foot rest and thereafter, the items were baked again under controlled condition. As a result a fine glazed surface is developed where the solution was applied. The production cost of one set of these items are expected to be Rs. Seventy only (base year 1993-94). The surface finish is superior to that of cement fittings and comparable to factory made glazed fittings.

ESTIMATE FOR SPLIT BAMBOO GRID SUPER STRUCTURE

1. Bamboos	5 Nos.	@ Rs.30/-	Rs.150.00
2. Nails	1 Kg	@ Rs.20/- per Kg	Rs. 20.00
3. G.I.Wire (Binding wire)	1 Kg	@ Rs.20/- per Kg	Rs. 20.00
4. Empty Cement Bags	10 Nos.	@ Rs.1/- per bag	Rs. 10.00
5. Cement	Quarter Bag	@ Rs.100/- per bag	Rs. 25.00
6. Sand	Quarter Bag	@ Rs.6/- per bag	Rs. 1.50
7. Sutli	100 gms	@ Rs.16/- per Kg	Rs. 1.60
8. Hinge	02 Nos.	@ Rs.5/- each	Rs. 10.00
9. Labour for structures	06 labours	@ Rs.35/-	Rs.210.00
10.Labour for plaster	03 Nos.	@ Rs.35/-	Rs.105.00

Total	Rs.553.10
--------------	------------------

Rs. Five hundred fifty three and paisa ten only.

SPLIT BAMBOO GRID SUPERSTRUCTURE (Both side with mud plaster) FOR LOW COST LATRINE

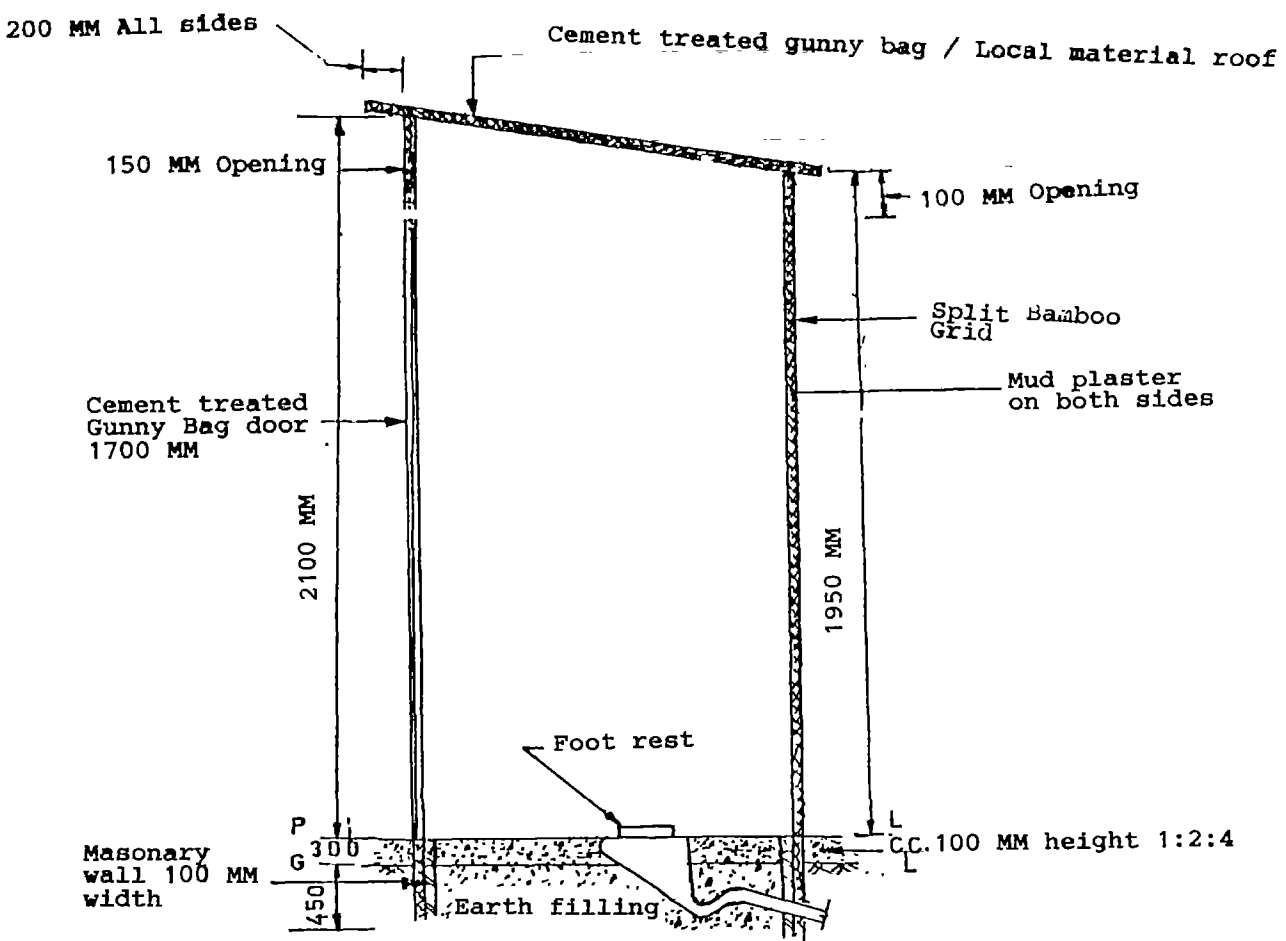

SEC. ELEVATION AB

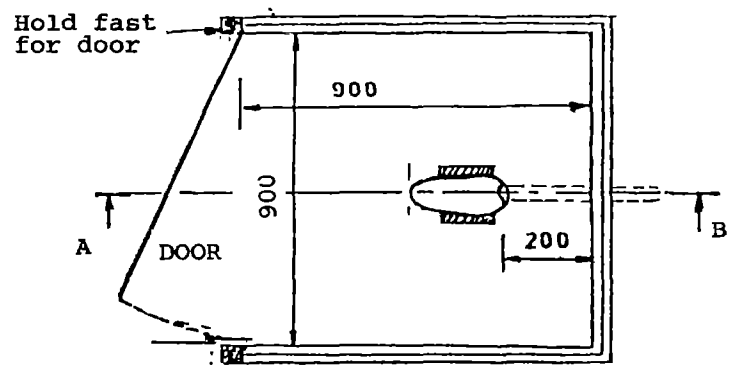

SEC. PLAN

ALL DIMENSIONS IN mm.

DETAILS OF SPLIT BAMBOO GRID SUPERSTRUCTURE

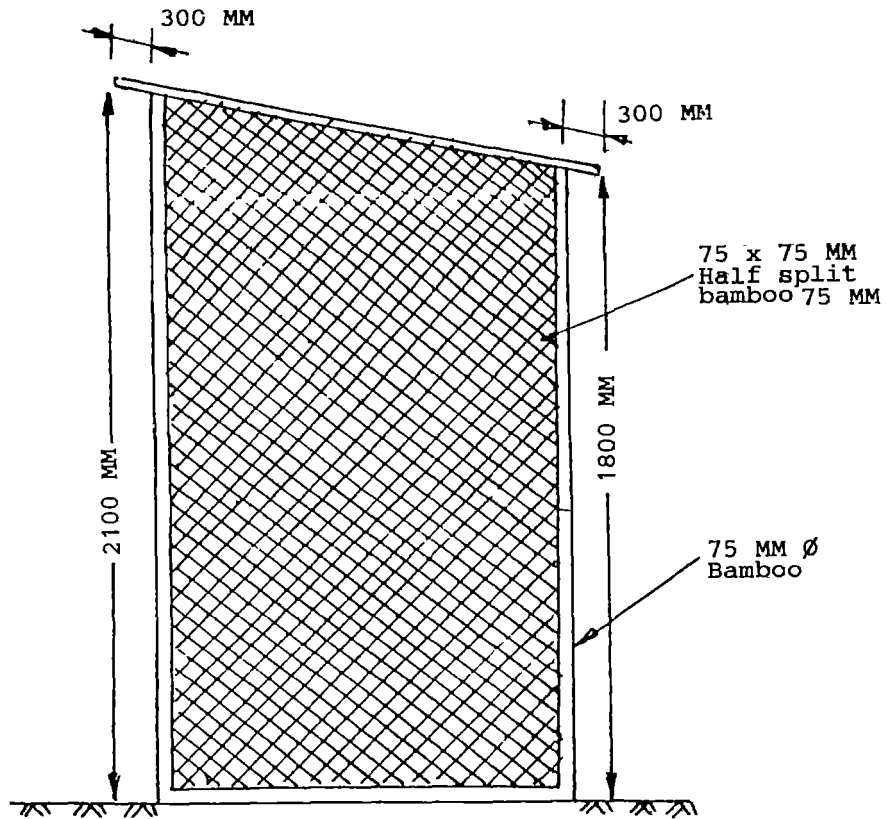

DETAIL OF SIDE WALL FRAME

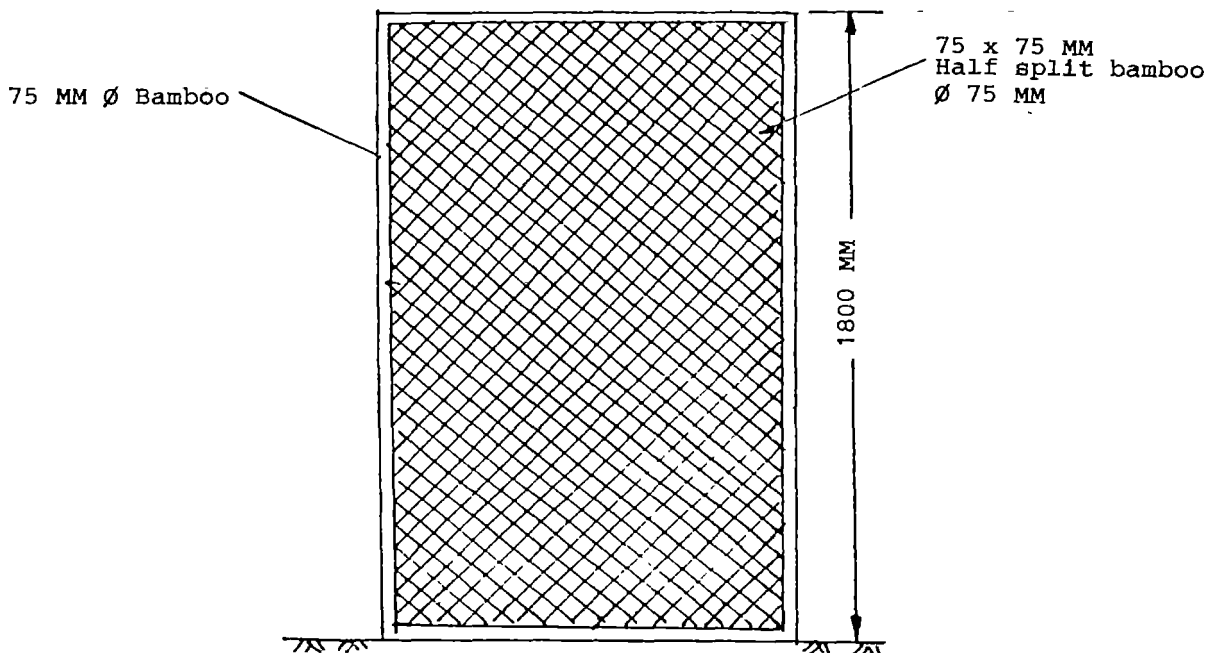

DETAIL OF BACK WALL FRAME

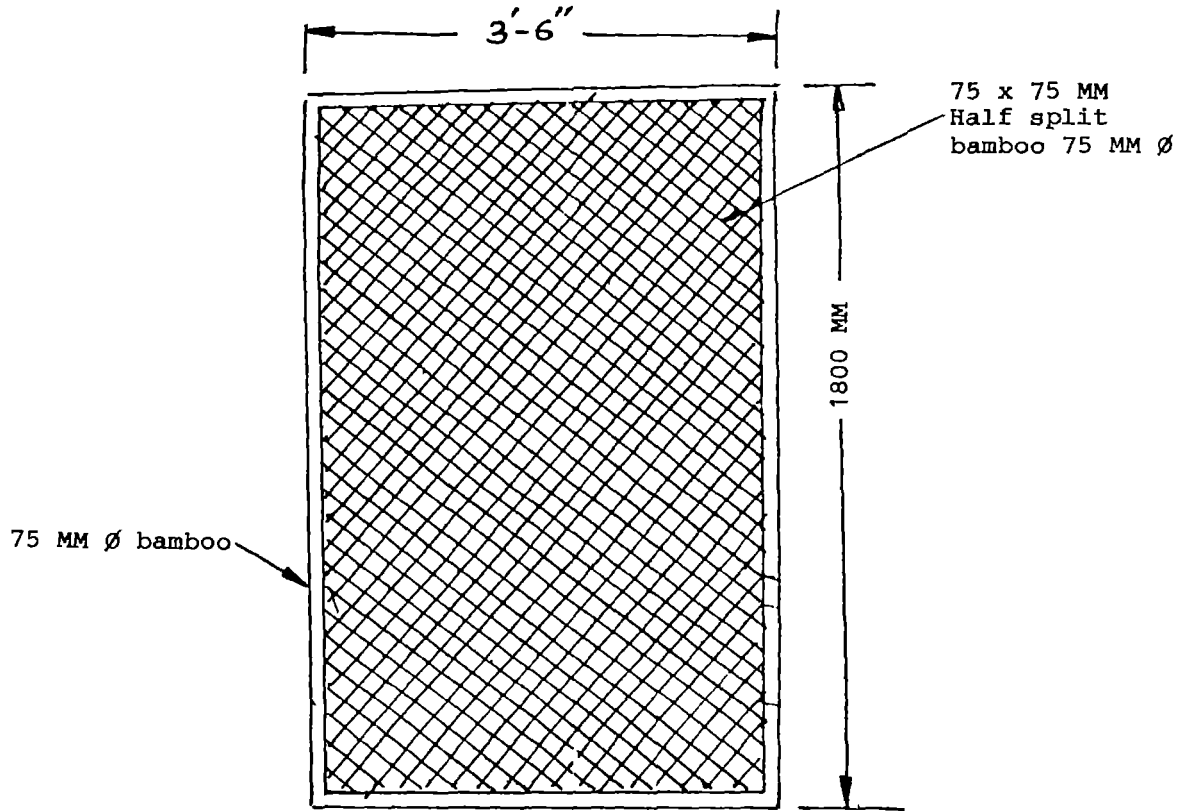

DETAIL OF DOOR FRAME

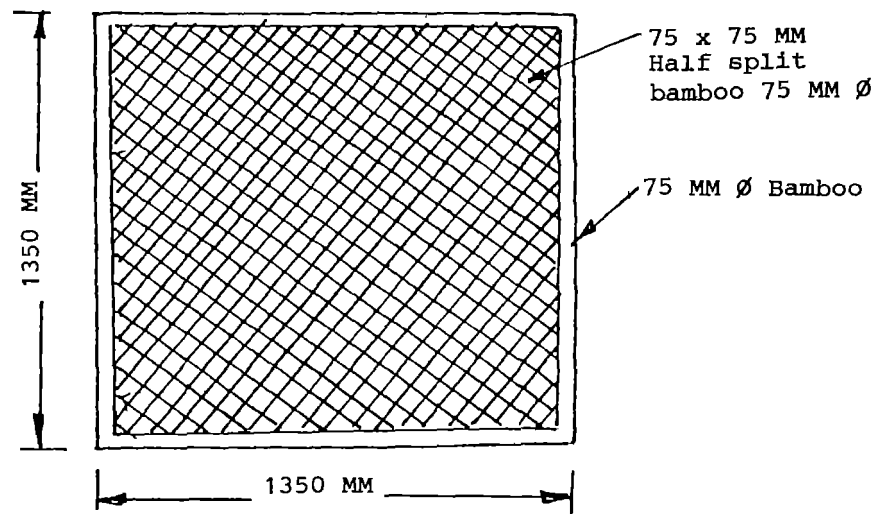

DETAIL OF ROOF FRAME

ESTIMATE FOR MUD BLOCK SUPERSTRUCTURE

1. Preparation of Mud Block	500 Nos.	@ Rs.300/- per 1000	Rs. 15.00
2. Empty Cement Bags	15 Nos.	@ Rs.1/- per bag	Rs. 15.00
3. Sutli	100 gms	@ Rs 16/- per Kg	Rs. 1.60
4. Cement	10 Kg	@ Rs.2/- per Kg.	Rs. 20.00
5. Hinge	02 Nos.	@ Rs.5/- each	Rs. 10.00
6. Sand	Quarter bag	@ 6/- per bag	Rs. 1.50
7. Bamboo	01 No	@ Rs.30/- each	Rs.30.00
8. Mason	01 No.	@ Rs.70/- per day	Rs.70.00
9. Labour	02 Nos.	@ Rs 35/- per day	Rs.70.00

Total	Rs.382.50
--------------	------------------

Rs.Three hundred eighty two and paisa fifty only

COMPRESSED MUD BLOCK SUPERSTRUCTURE FOR LOW COST LATRINE

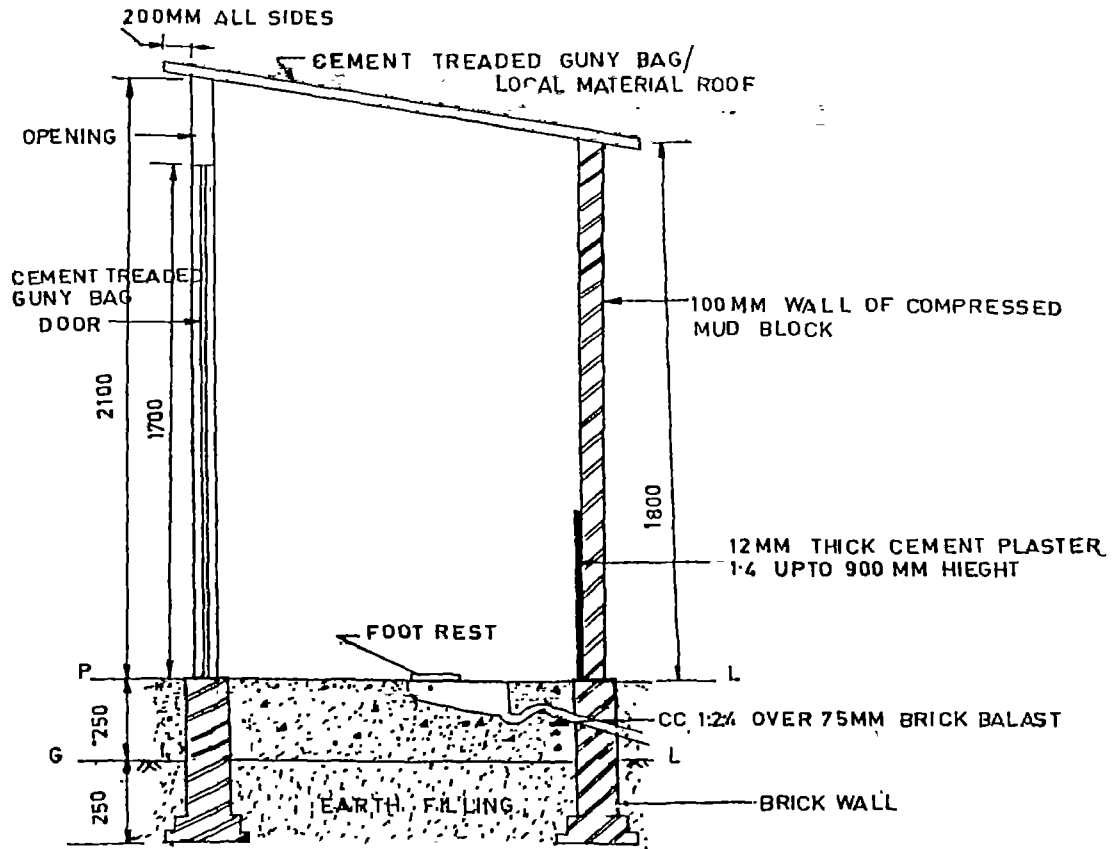

SEC. ELEVATION

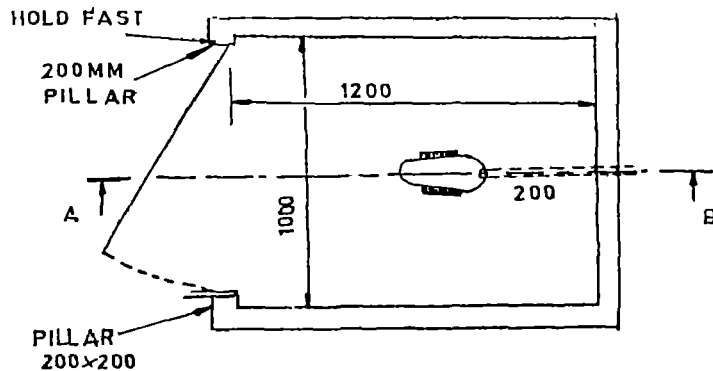

SEC. PLAN (All Dimensions in MM)

ESTIMATE FOR CEMENT TREATED GUNNY BAG SUPERSTRUCTURE OF LOW COST LATRINE

1. Empty Cement Bag	20 Nos.	@ Rs.1/- per bag	Rs. 20.00
2. Nails	250 gms.	@ Rs.20/- per Kg.	Rs. 5.00
3. G.I.Wire (Binding wire)	250 Gms.	@ Rs.20/- per Kg	Rs. 5.00
4. Bamboo (3" dia)	02 Nos.	@ Rs 30/- each	Rs. 60.00
5. Cement	Half bag	@ Rs.90/- per bag	Rs. 45.00
6. Sutli	250 gms.	@ Rs.16/- per Kg.	Rs. 4.00
7. Sand	Half bag	@ Rs.6/- per bag	Rs. 3.00
8. Labour	03 Nos.	@ Rs.35/- per day	Rs.105.00

Total	Rs.245.00
--------------	------------------

Rs. Two hundred and forty five only

CEMENT TREATED GUNNY BAG SUPERSTRUCTURE FOR LOW COST LATRINE

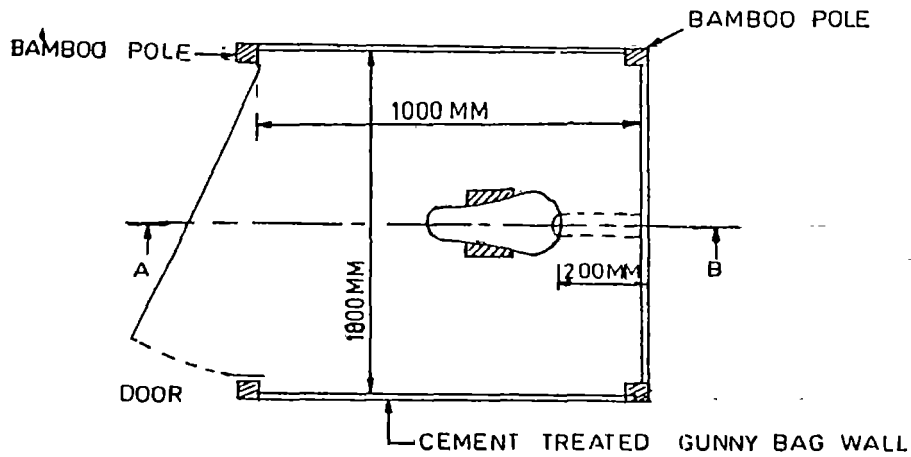
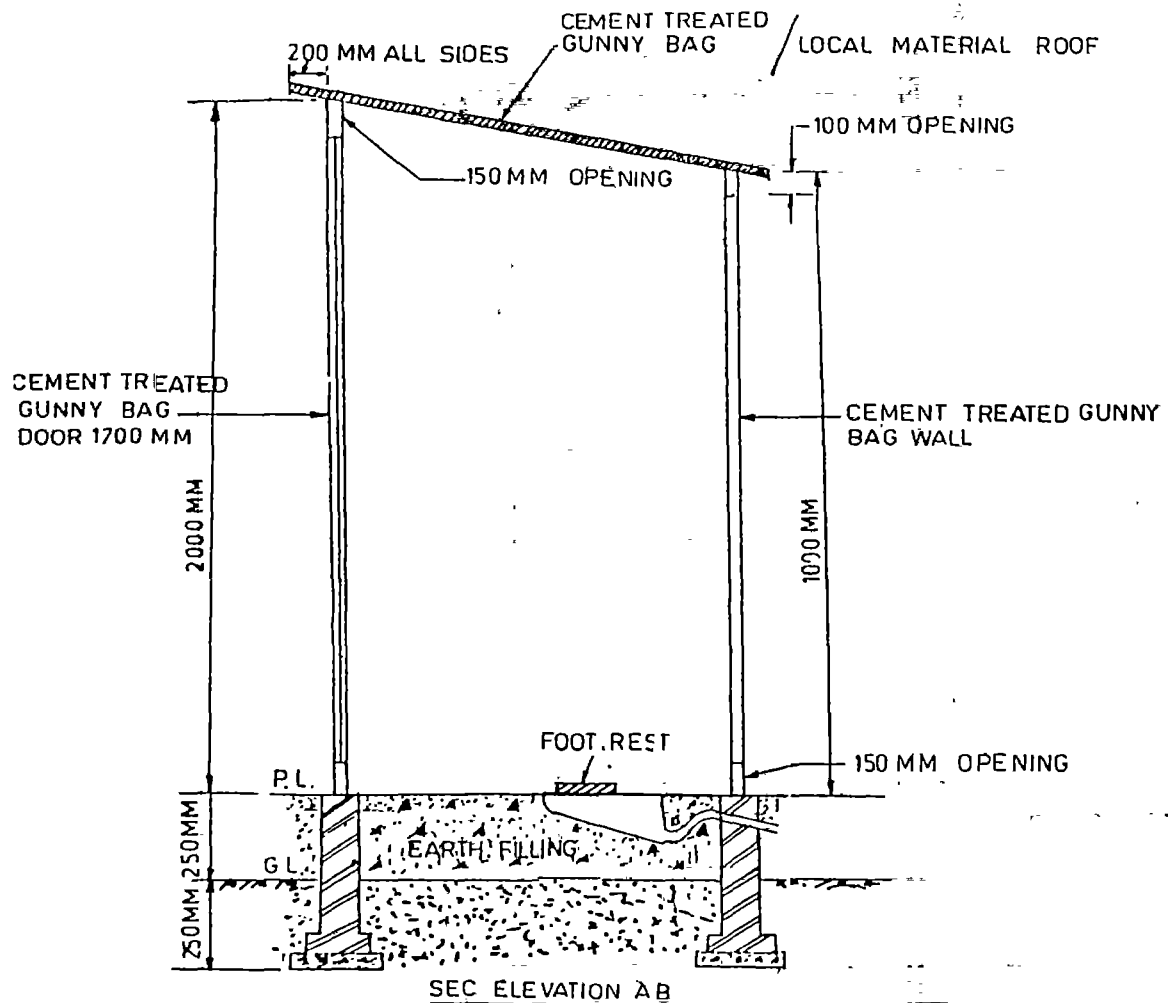

DETAIL OF CEMENT TREATED GUNNY BAG SUPERSTRUCTURE

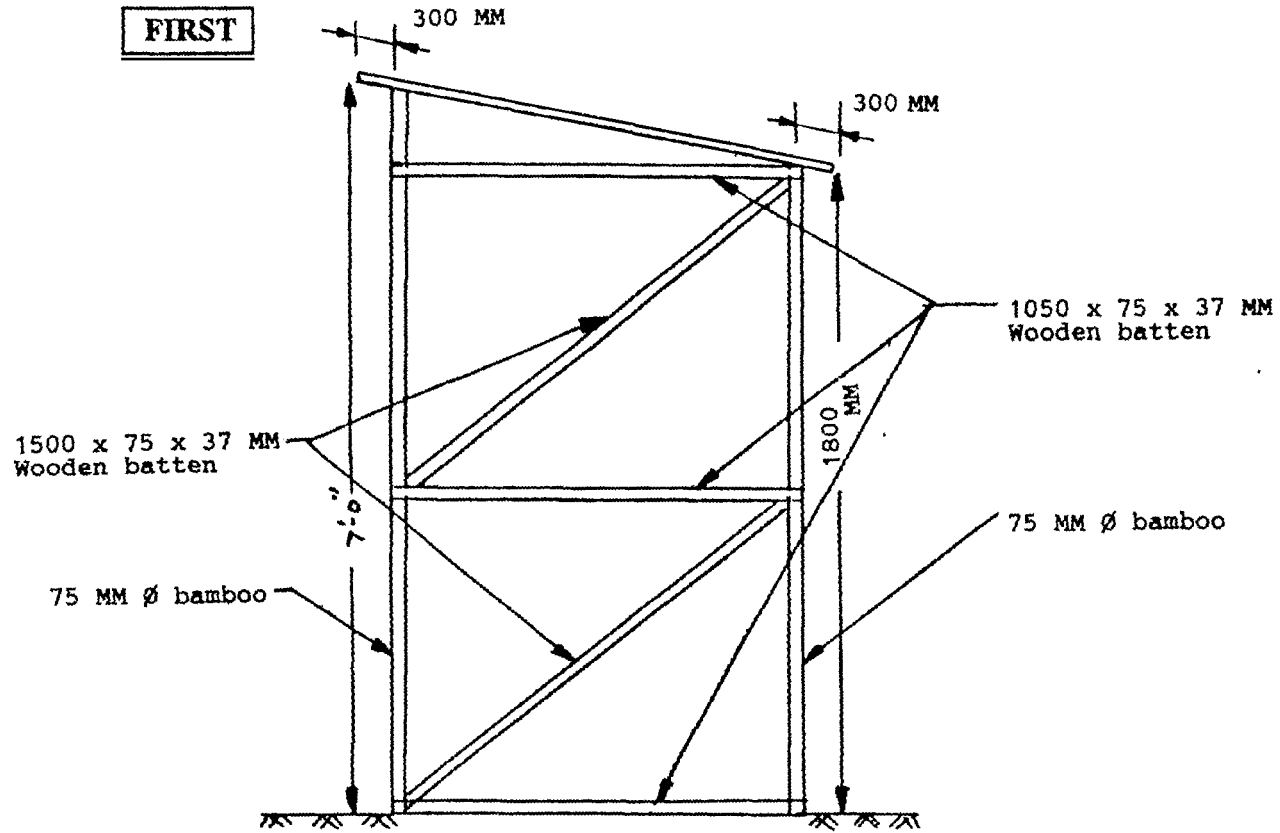

DETAIL OF SIDE WALL FRAME

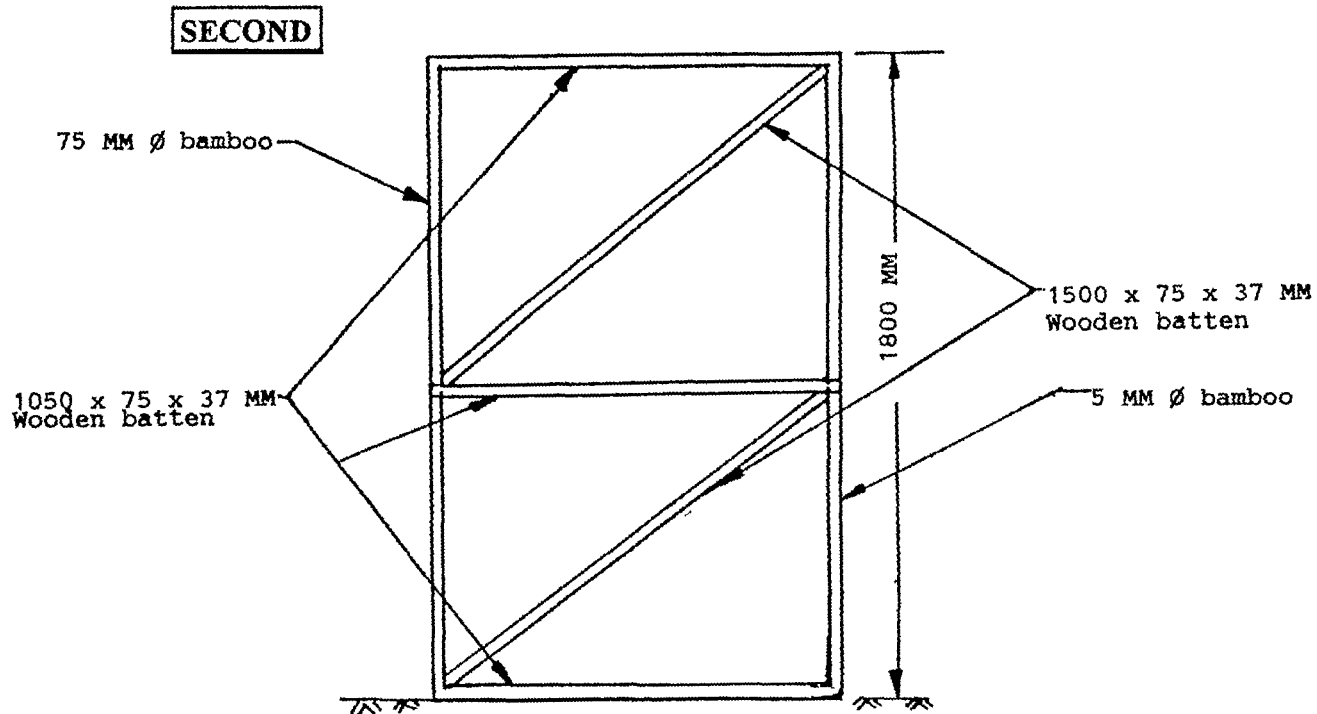

DETAIL OF BACK WALL FRAME

THIRD

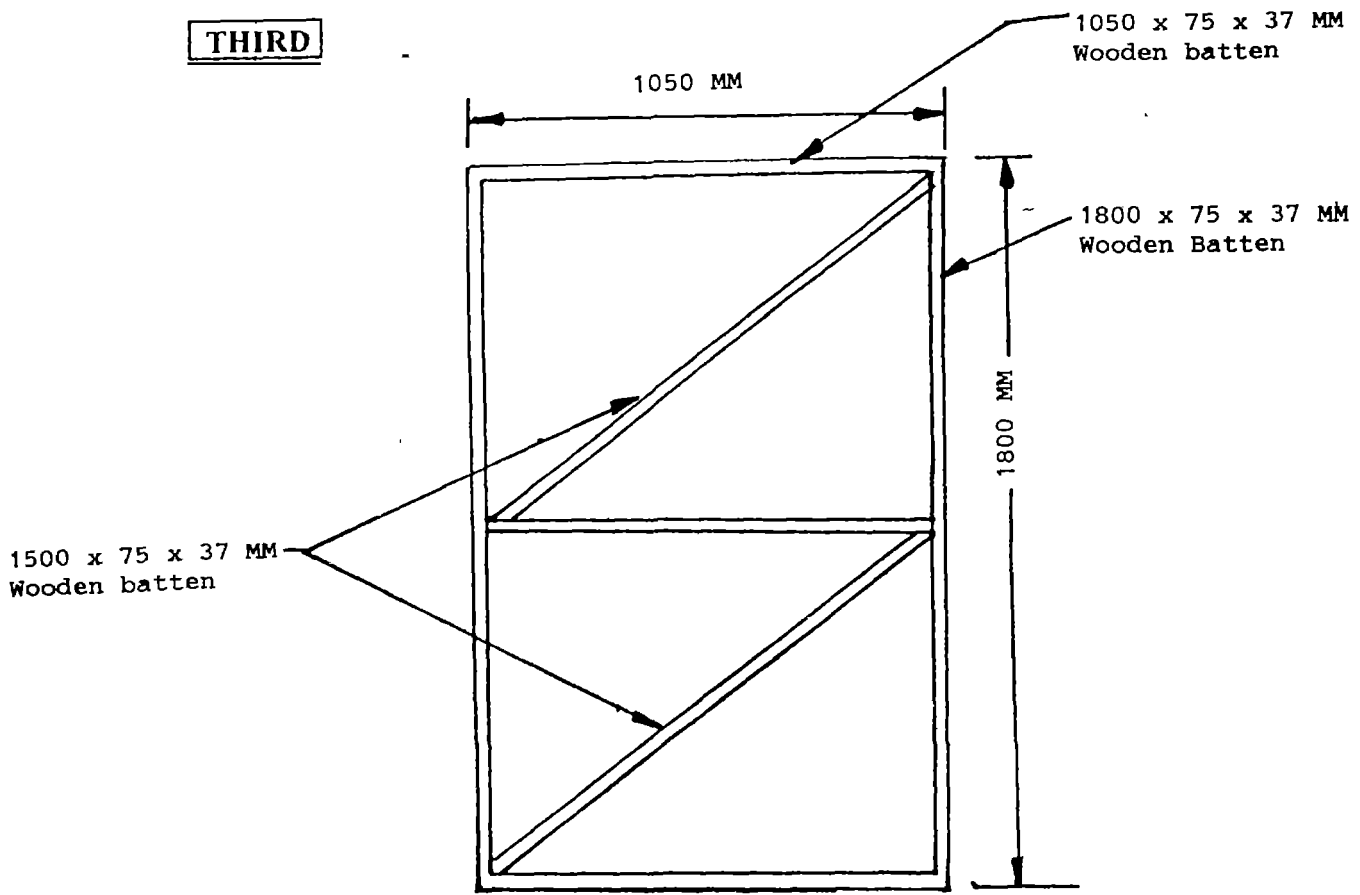

DETAIL OF DOOR FRAME

FOURTH

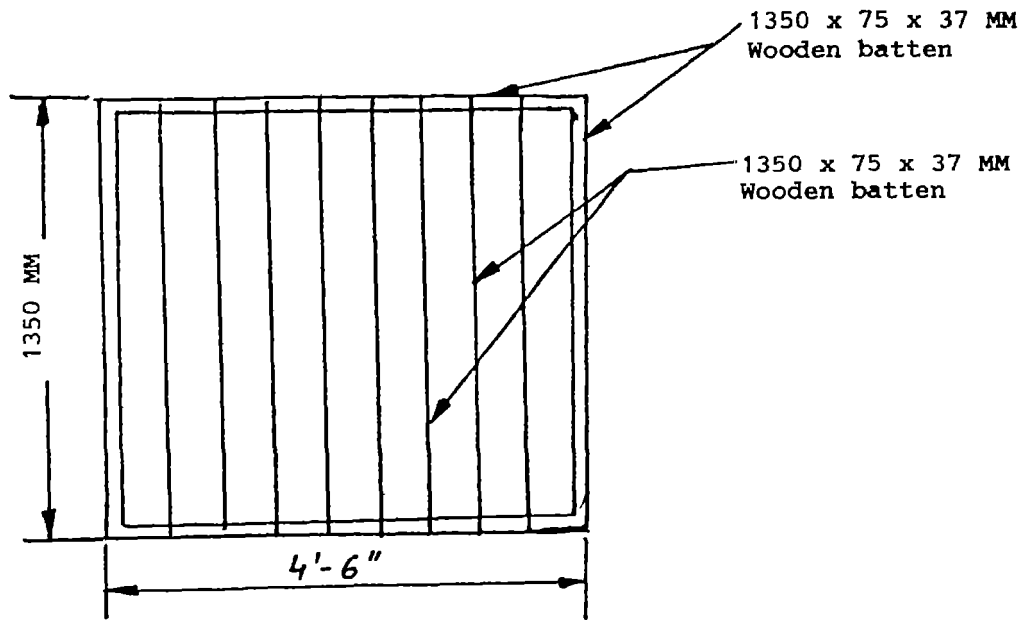

DETAIL OF ROOF FRAME

LOW COST SEMI-FLUSH FERRO-CEMENT LATRINE

GENERAL

Low cost latrine designs require many solutions to meet varying socio-economic and technical situations. Ferro-Cement Technology, specially the precast / prefabricated technique has been successfully applied to develop a complete toilet structure (alongwith excreta disposal pits) design.

SEMI-FLUSH FERRO-CEMENT LATRINE

Semi-Flush / Hand-Flush Ferro-Cement precast latrine has been found to offer a solution of the sanitary problems. It needs less quantity of water, is hygienic and economical in construction and maintenance. The greatest advantage is that whole structure is precast and can be erected at site in two days time.

Semi-Flush Latrine is also called the Hand-Flush Latrine. The flushing is done by throwing water with a bucket or a tin. All the units except pillars are

precast ferro-cement units and the pillers are precast R.C.C. Units.
Constructional details follows :

CONSTRUCTION OF LATRINE

SIZE

Internal size of the latrine varies from 750 x 900 mm to 900 x 1,000 mm. A size of 900 x 1,000 mm is more convenient and has been adopted by the majority of the people. The door opening is 550 x 800 mm. Flooring consists of 25 mm thick 1:2:4 C.C. Internal height of the latrine excluding ridge is 2100 mm. Plinth is raised 150 mm above ground level.

PILLERS

The length of each precast R.C.C. (1:1 5:3) pillers are 2.25m and there are 1.80 m above floor level. Lower ends of the pillers are grouted below ground level upto a depth of 300 mm in 1:3:6 cement concrete block of size 300 x 300 x 300 mm. The pillers are 75 x 75 mm in section and are reinforced with two 6 mm dia bars and rings are spaced at 300 mm C/C. They are five in number and are of same length. They are casted with recesses of 20 x 10 mm on vertical faces, as shown in the drawing number 4, given at the end of this chapter.

PANELS

To complete the sides of the super structure, precast ferro-cement panels of size 960 x 300 x 15 mm are inserted in recesses of pillers. Similarly the back and front are completed by inserting panels of size 860 x 300 x 15 mm and

230 x 300 x 15 mm into the recesses of pillars respectively. A precast lintel as shown in the drawing number 3 is used on the door opening. At front, back and sides, top most panels are provided with 75 mm dia holes for ventilation purposes. Roof consists of two panels sloping side-ways with a tide piece at top. All the panels are precast in 1:3 cement mortar and chicken mesh used as reinforcing material in the centre of the thickness of the panel. The joints of the panels from outside are finished in cement mortar 1:3 as raised ribs, and inside flush. Inside surface of the latrine is white washed and outer surface painted with a coat of neat cement slurry. The constructional details of the latrine are shown from drawing number 1 to drawing number 5.

W.C.PAN

A 425 mm glazed vitreous china rural pattern W.C. Pan with a pair of footrest of same material has been provided.

P-TRAP

P-traps are made out of 1:2 cement mortar with a seal of 20 mm. The inner dia of the trap is 100 mm. These traps have proved very useful and are being adopted successfully in the field.

INSPECTION CHAMBER

An inspection chamber of size 300 x 300 x 250 mm is constructed between the trap and waste pits. Waste pits are connected with the chamber by separate drains. It can be constructed by the help of bricks or stones, precasted from inside and covered from the top by a precasted reinforced

slab 25 mm thick. It consists of two diversion channels, one of which is put in use and the second one kept closed by providing a small shutter made of a waste roofing slate or of a tin sheet. The shutter fits in recesses made for this purpose. More details, consult drawing number 1 and 2 (given at the end of this chapter).

WASTE PITS

Two waste pits are constructed for the disposal of waste from the latrine. One pit remains in continuous use for about 4 to 5 years and then the second one is put to use. Using alternately, these pits function for a longer period by maintaining them properly.

SIZE AND SHAPE

The pits may be rectangular, square or circular in shape. Generally, square and circular pits are used. Square pits are easy to construct. The size of a square pit is 750 x 750 mm and 1300 mm deep. The circular pits are 750 mm dia internally and 1300 mm deep. In the present design circular pits have been shown / used as they are more stable. The depth can be varied depending upon capacity and strata.

INTERNAL LINING OF WASTE PITS

The waste pits are lined from inside by honey combed bricks masonry or with precast ferro-cement rectangular or circular panels. When brick masonry

is used for lining, two courses each at bottom and top are made solid to make the lining stable. The base of the pit is kept katcha, if honey combing is not provided the percolation of water reduces slightly but does not effect the performance of the pits much. The Community Development Cell of IERT, Allahabad, under the guidance of IERT's Centre for development of Rural technology has developed rectangular and circular precast ferrocement panels 20 mm thick cast in 1:3 cement mortar and 75 mm diameter circular holes are provided in the panels for honey combing. Rectangular panels are 4 in number for each pit, and for circular pits 3 or 4 curved panels are provided for each pit. For sizes and other details refer to drawings. The circular waste pit panels have provided much stable and strong and their handling is also easy & less liable to breakage. A pit of required size is dug in circular shape, three four curved panels are placed vertically with abutting joints. The extra excavation outside the pit panels, if any, shall be filled with broken stones and sealed with 150 mm thick 1:2 4 C.C. at the top.

PIT COVER SLABS

Circular pits are kept covered with circular dome shaped slabs of 20 mm thickness. The curvature in the slab increases its strength. A layer of chicken mesh is also provided at the centre to strengthen the slab. It is stronger than a flat slab of the same dimension. M.S. Bar 6 mm dia handles are provided to lift the covers. Rectangular or square pits are covered from top by 40 mm thick reinforced C.C. flat slabs.

QUANTITY OF WATER REQUIREMENT FOR FLUSHING

Very less quantity of water is required for flushing the night soil as the water

seal in the trap is only 20 mm. The quantity of water required for flushing is one to two litres and it has been established practically.

COST

The cost of the latrine including casting and erection and complete in all respects on the basis of 1993-94 market rates is estimated to Rs. Three thousand seven hundred and thirty five only, excluding transportation charges. A cost analysis is also provided at the end of the chapter

ADVANTAGES

- It is cheaper as compared to other types
- It is good looking.
- It is durable.
- It is easy to transport as all the units can be handled easily.
- It does not require any vent pipe.
- It does not create any nuisance or pollution.
- It can be constructed in any type of soil except rocky soil and water logged soil.
- Maintenance cost is almost nil
- Very less quantity of water (1 to 2 litres) is required for flushing the night soil.
- It requires less space for construction.
- Manure of good quality is obtained.
- It is easy to clean the pit whenever required.

- An ordinary mason can cast and erect the latrine easily.
- The space above the pits can be used for other purposes as they are tight.
- It is well ventilated.

PRECAUTIONS

- Stones and rags should not be thrown into the W.C.
- A cleaning brush should be kept in the latrine to clean W.C.
- The inspection chamber should be checked against blockade off and on.
- After a continuous use of 4 to 5 years, the diversion should be made to the second pit from the inspection chamber.
- Steel shutter should be painted once a year.
- The pit covers should not be subjected to a heavy load

DETAILED BREAK UP OF COST OF FERRO-CEMENT LATRINE

SIZE : 900 x 1,000 mm. with two waste pits.

1. MATERIAL COST

1.1 Cement	5 Bags	@ 100/- per bag	500.00
1.2 Sand (Fine aggregate)	0.50 Cu.M.	@ 150/- per Cu.M.	75.00
1.3 Course Aggregate	0.25 Cu M.	@ 500/- per Cu.M.	125.00
1.4 M.S. Round 6 mm dia including binding wire	12 Kg.	@ 12/- per Kg.	144.00
1.5 Chicken Mesh	18 Sqm.	@ 10/- per Sqm.	180.00
1.6 W.C. (China ware) : P.Trap & Foot Rest			350.00
1.7 Steel Shutter (550 x 1800 mm)			400.00
1.8 Finishing white washing & painting etc			100.00
1.9 GI Pipe 15 mm dia, 75 mm long rsvh including cutting and grinding	02 Nos.	@ 7/- each	14.00

TOTAL Rs.1,888.00

2. LABOUR COST

2.1	Mason day for casting	06 days	@ 80/- per day	480.00
2.2	Mason day for erection	04 days	@ 80/- per day	320.00
2.3	Helper day for casting	06 days	@ 40/- per day	240.00
2.4	Helper day for erection	08 days	@ 40/- per day	320.00

TOTAL Rs.1,360.00

Total 1 and 2 above : 1,888.00 + 1,360 = Rs.3,248.00

Supervision charges and contingency @ 15% = Rs. 487.00

GRAND TOTAL Rs.3,735.00

LOW COST SEMI-FLUSH FERRO-CEMENT LATRINE

(PRECAST) 900 X 1,000 mm

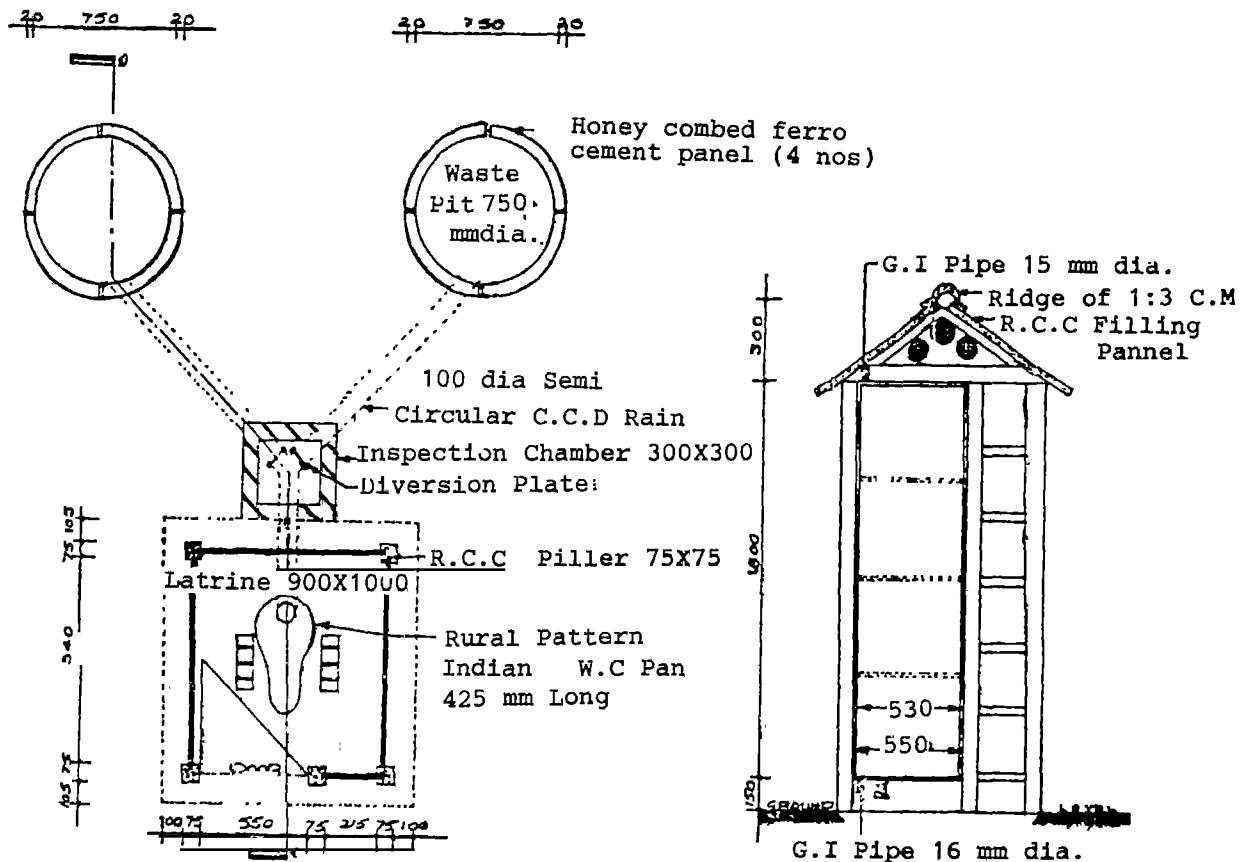

PLAN

FRONT ELEVATION

Drawing No.1 (All dimensions in mm)

LOW COST SEMI-FLUSH FERRO-CEMENT LATRINE

(PRECAST) 900 X 1,000 mm

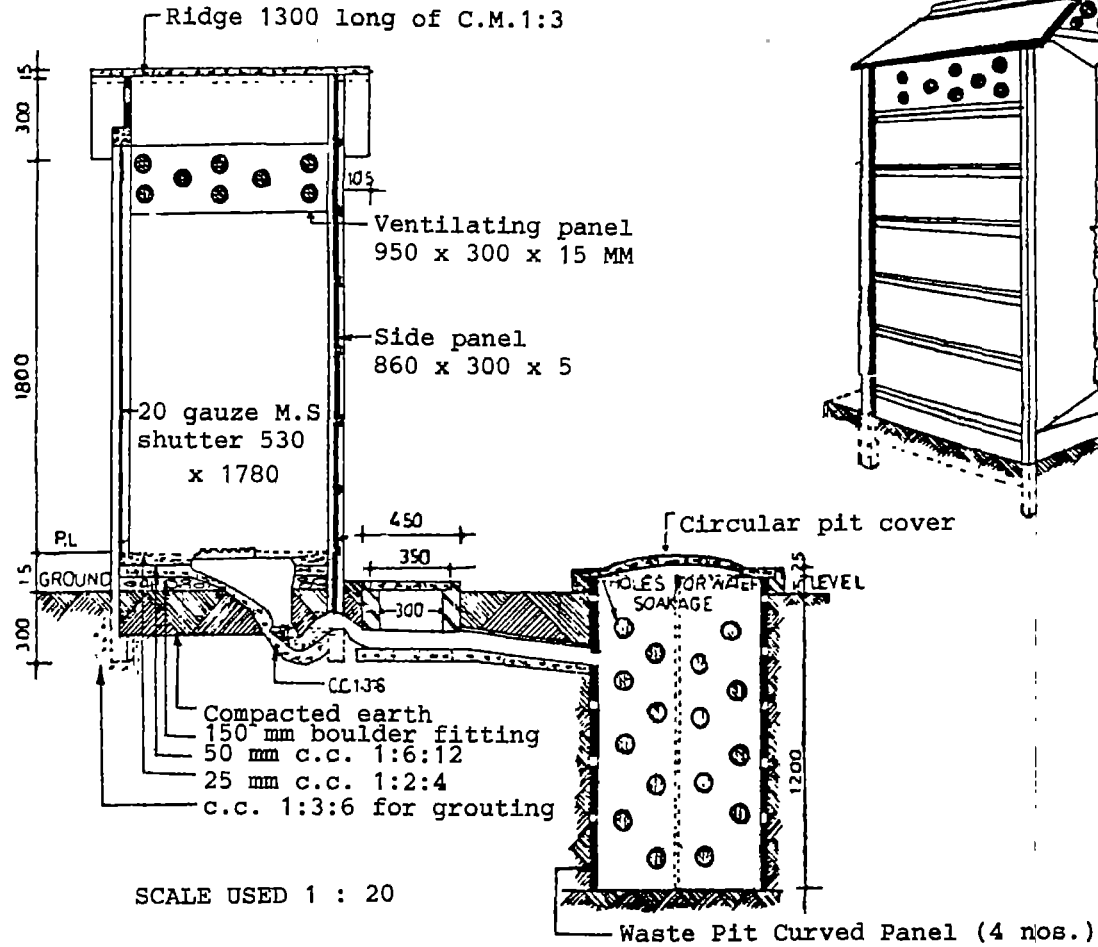

SEC. AT AB OF DRAWING NO. 1 (All dimensions in mm)

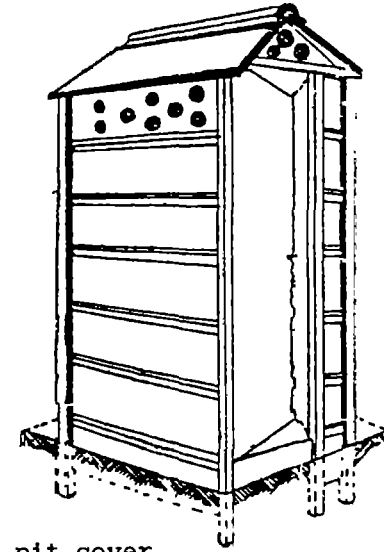

Drawing No.2

LOW COST SEMI-FLUSH FERRO-CEMENT LATRINE

DETAILS OF PANELS

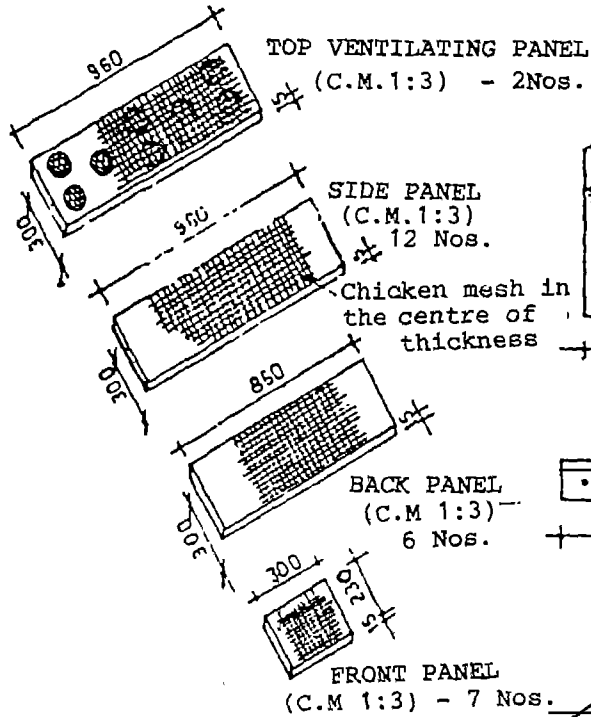

SCALE USED 1:23

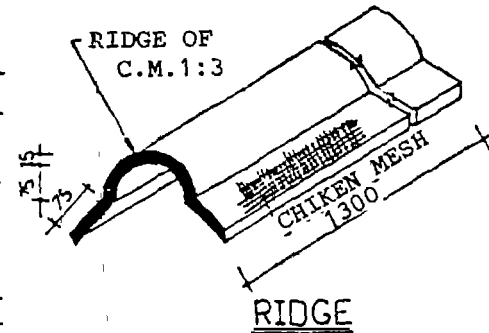
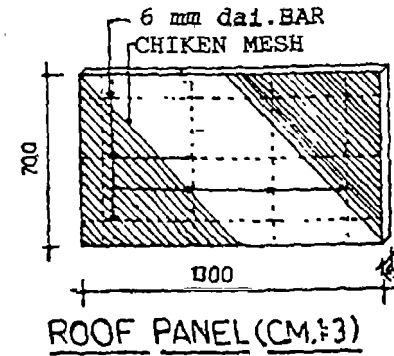
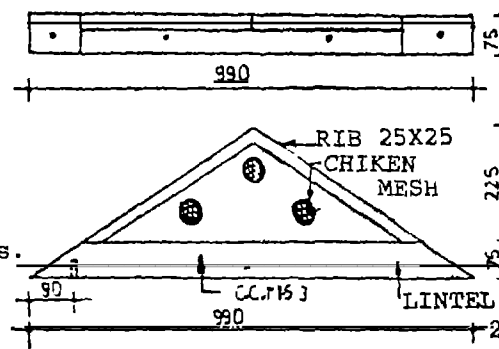
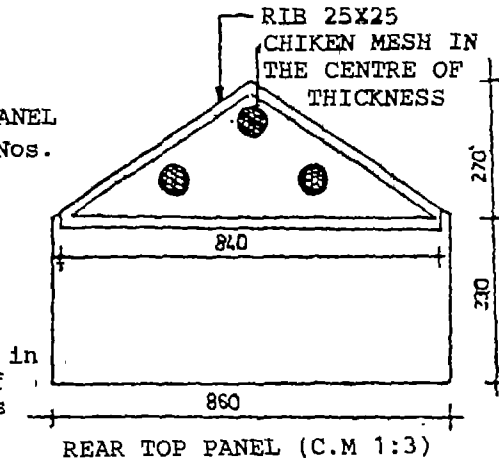

Drawing No.3 (All dimensions in mm)

LOW COST SEMI-FLUSH FERRO-CEMENT LATRINE

DETAIL OF R.C.C PILLARS

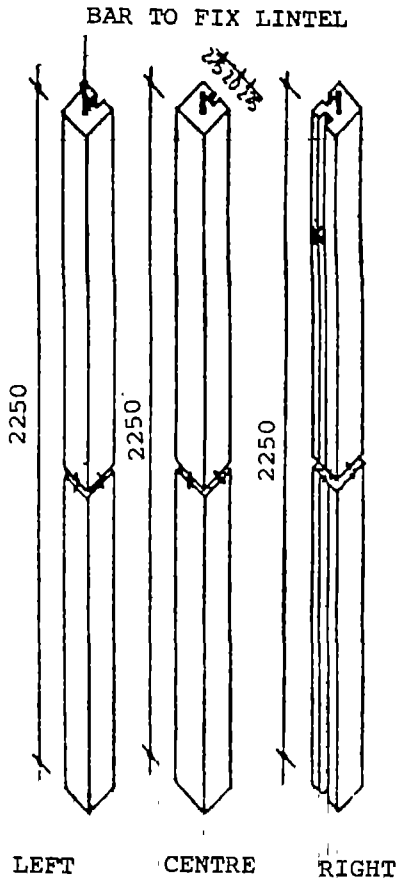

FRONT PILLER

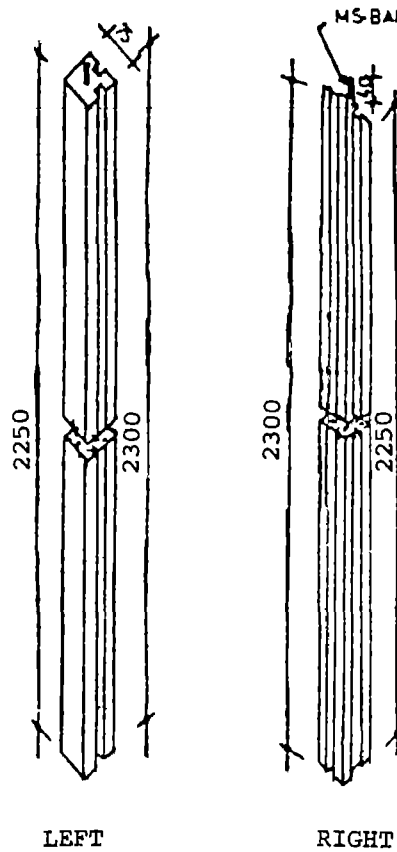

REAR PILLER

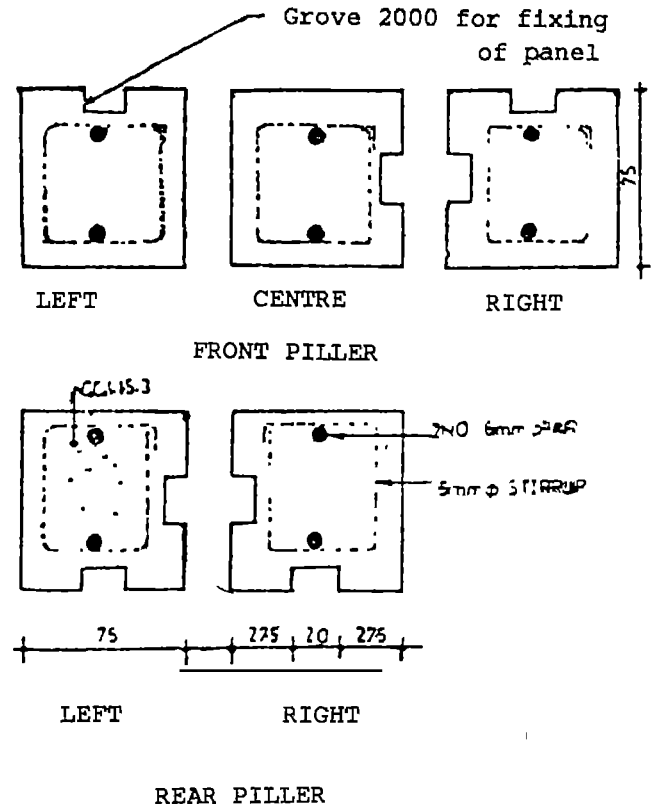

Drawing No.4 (All dimensions in mm)

LOW COST SEMI-FLUSH FERRO-CEMENT LATRINE

DETAIL OF WASTE PIT

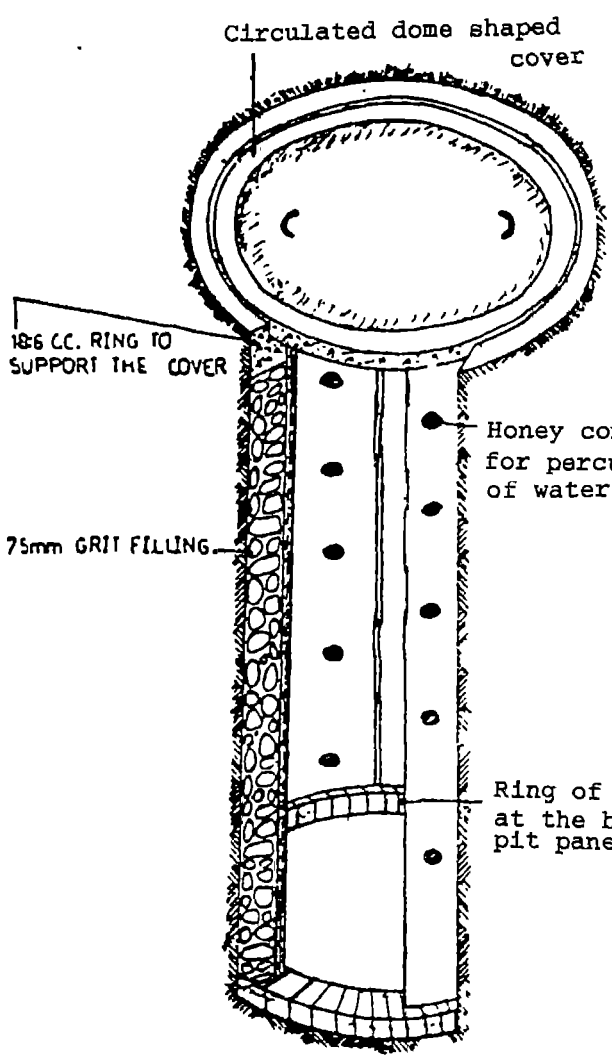

WASTE PIT

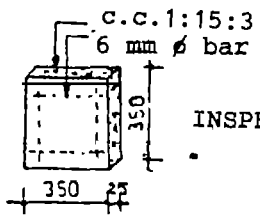

INSPECTION CHAMBER COVER

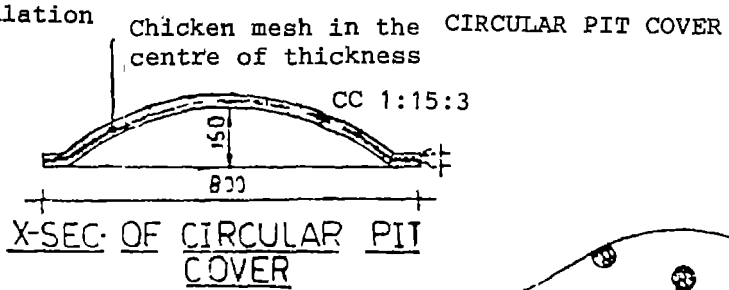
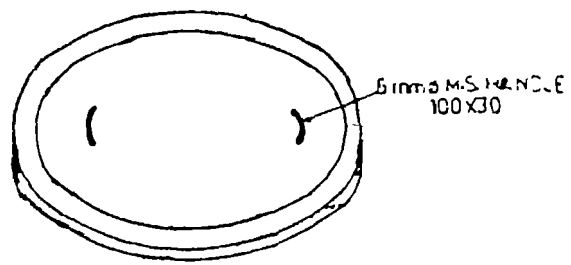

X-SEC. OF CIRCULAR PIT COVER

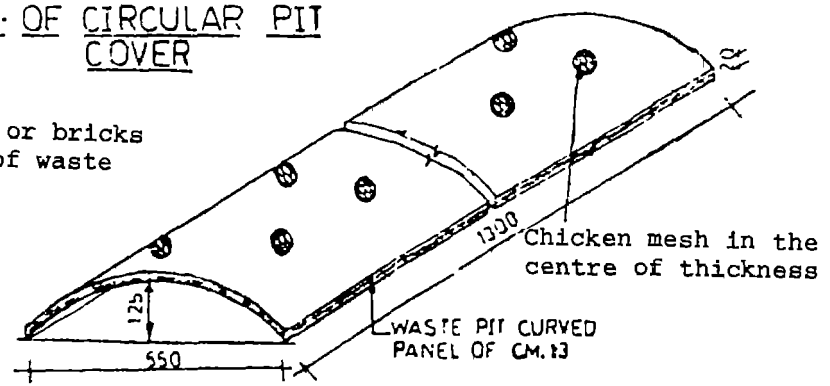

WASTE PIT CURVED PANEL

Drawing No.5 (All dimensions in mm)

This work was carried out with the aid of a grant from
International Development Research Centre, Ottawa, Canada

For further information contact :

INFORMATION DIVISION

Centre for Development of Rural Technology

Institute of Engineering & Rural Technology

26, Chatham Lines, Allahabad - 211 002, India

Phone 0532-644402 Fax 0532-641635 Gram . APOLY