

3 4 2

8 1 U



Manuals of British Practice in Water Pollution Control

Unit Processes

SEWAGE SLUDGE II: CONDITIONING, DEWATERING and THERMAL DRYING

The Institute of
Water Pollution Control
Ledson House, 53 London Road,
Maidstone, Kent. ME16 8JH
1981

342 814N
1268

For complete details of the
Institute's publications, contact
for complete details of the
Institute's publications, contact

LIBRARY
International Reference Centre
for Community Water Supply

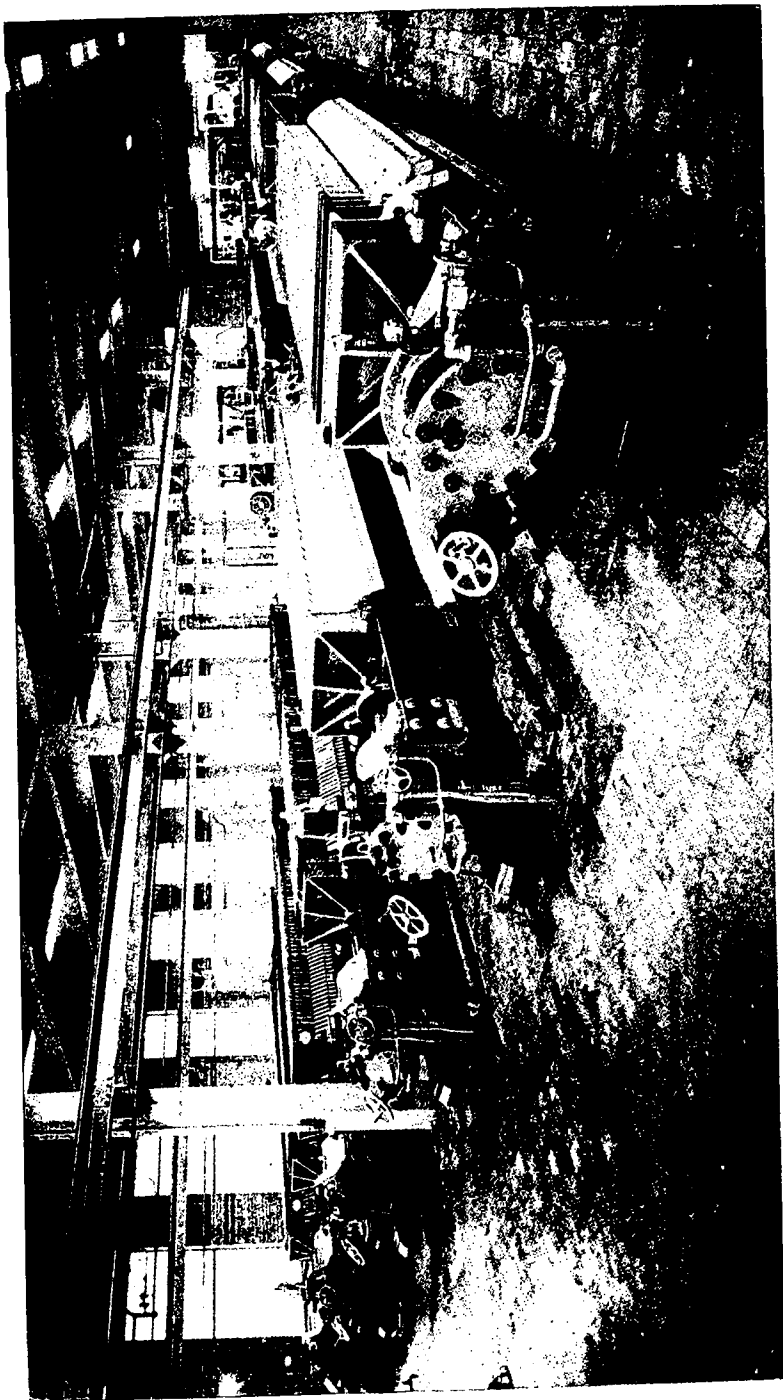

Interior of presshouse at Huddersfield sewage-treatment works

342
814N

Manuals of British Practice
in Water Pollution Control

1268
LIBRARY
International Reference Centre
for Community Water Supply

Unit Processes
SEWAGE SLUDGE II:
CONDITIONING, DEWATERING
and
THERMAL DRYING

The Institute of
Water Pollution Control
1981

THE INSTITUTE OF WATER POLLUTION CONTROL

President:

C. P. James, F.I.W.E.S., F.I.P.H.E., F.B.I.M. (Fellow)

Editorial Sub-Committee:

H. A. Hawkes (*Chairman*)

Isabel M. Lamont (*Secretary*)

N. E. W. Sambidge (*Co-ordinator*)

D. M. Barlow

A. M. Bruce

B. E. Butler

E. I. Clark

M. D. F. Haigh (*Editor*)

V. H. Lewin

E. B. Pike

P R E F A C E

In 1970 the Council of the Institute of Water Pollution Control discussed the question of the publication of definitive manuals on the subject of British Practice in Water Pollution Control, and concluded that such publications would generally be welcomed.

The Institute's publication An Introduction to Sewage Treatment will continue to serve as a general guide to the layman interested in the subject, whilst the manuals will, it is hoped, cover the subject in sufficient depth to become accepted as a reference source for those already actively engaged in this field, as well as for students seeking authoritative guidance when preparing for professional qualifications.

The need for three manuals to deal with sludge treatment and disposal indicates the importance of this part of sewage treatment. This manual covers processes which have been used to dewater sewage sludge, the nature of which has changed as sewage-treatment processes have changed. Sludge treatment has also benefited from technological advances in other fields.

The earliest sludge dewatering process was simply to allow sludge to remain in a shallow lagoon until it had dried sufficiently for men to shovel it out as a cake. The filter press was established as a sludge dewatering process soon after 1980, long before biological filtration became established; the introduction of the activated-sludge process was later to have a profound effect upon sludge dewatering. To date, sludge dewatering is not generally carried out without prior conditioning and the first two chapters, Sludge Conditioning and Sludge Dewatering describe what, at many sewage works, is a single integrated process. The final chapter about Thermal Drying will be of interest to fewer readers, but nevertheless describes a process which has been employed at several sewage-treatment works.

During the preparation of this manual many persons, too numerous to name, and including staff of the Water Research Centre, Stevenage, have read

drafts and offered advice. The following have made substantial contributions: R. C. Baskerville, C. E. Brade, A. M. Bruce, B. E. Butler, C. N. L. Cree, J. Dutson, G. A. Hirst, E. Kaye, E. Needham, P. F. Roberts, N. E. W. Sambidge, D. Small, R. Sutcliffe and the late Harry Stanbridge. Without the willing contributions from all these, the production of this manual would have been more difficult and less authoritative. The Sub-Committee of the Institute's Publications Committee, which has been responsible for the production of this manual, wishes to record its thanks to all those who have helped.

*H. A. Hawkes
Chairman*

CONTENTS

PREFACE	5
1. SLUDGE CONDITIONING	13
1.1 Introduction	13
1.2 Methods of assessment	13
1.2.1 Visual observation by beaker test	14
1.2.2 Gravity drainage tube test	16
1.2.3 Capillary suction time (CST) filtrability apparatus	18
1.2.4 Standard shear test	19
1.2.5 Buchner funnel apparatus for determination of specific resistance to filtration	23
1.3 Elutriation	24
1.3.1 Introduction	24
1.3.2 Mechanism	25
1.3.3 Application	25
1.3.4 Design and operation	25
1.3.5 Performance	26
1.4 Chemical conditioning	27
1.4.1 History	27
1.4.2 Lime and copperas	27
1.4.3 Aluminium chlorohydrate	28
1.4.4 Polyelectrolytes	28
1.4.5 Factors affecting coagulant demand	31
1.4.5.1 Type of sludge	31
1.4.5.2 Period of storage	32
1.4.5.3 Mixing	32
1.5 Thermal conditioning	32
1.5.1 Introduction	32
1.5.2 Types of plant and application	33
1.5.2.1 Heat-treatment process	33
1.5.2.2 Zimpro process	33
1.5.2.3 Thermal conditioning with air	33
1.5.3 Principle of process	33
1.5.4 Operation	34

1.5.4.1	Preliminary treatment	34
1.5.4.2	Heating and recovery	34
1.5.4.3	Continuous-flow settlement	35
1.5.4.4	Odour nuisance	35
1.5.5	Maintenance	35
2.	SLUDGE DEWATERING	37
2.1	Introduction	37
2.2	Drying beds	38
2.2.1	Introduction	38
2.2.2	Mechanism	38
2.2.3	Preliminary treatment of sludge	39
2.2.4	Design	40
2.2.4.1	Area of beds	40
2.2.4.2	Inlets	40
2.2.4.3	Media	41
2.2.4.4	Underdrains	41
2.2.4.5	Floor	41
2.2.4.6	Walls	41
2.2.4.7	Covers	41
2.2.4.8	Provision for removal of dried sludge	42
2.2.4.9	Withdrawal of separated liquor	42
2.2.5	Operation	42
2.2.5.1	Preparation of bed surface	42
2.2.5.2	Application of sludge	42
2.2.5.3	Lifting dried sludge	43
2.2.5.4	Odour problems	43
2.2.6	Maintenance	43
2.2.6.1	Replenishment of top dressing	43
2.2.6.2	Lifting machines	43
2.2.7	Performance	43
2.2.7.1	Factors affecting performance	43
2.2.7.2	Loading	44
2.2.7.3	Separated liquor	44
2.3	Filter Press	45
2.3.1	Introduction	45
2.3.2	Design	45
2.3.2.1	Types of filter press	45
2.3.2.2	Buildings	46
2.3.2.3	Sludge storage and conditioning tanks	46
2.3.2.4	Press feed pumps and ancillary equipment	46
2.3.2.5	Plates and drainage	47

2.3.2.6	Mechanization	49
2.3.2.7	Filter cloths	49
2.3.2.8	Cake handling and disposal	52
2.3.3	Application	52
2.3.4	Operation	53
2.3.4.1	Sludge conditioning and mixing	53
2.3.4.2	Rate of feed and pressure	54
2.3.4.3	Pressing period	54
2.3.4.4	Maintenance of plates and cloths	55
2.3.5	Performance	56
2.4	Rotary-drum vacuum filter	56
2.4.1	Introduction	56
2.4.2	Principle of operation	57
2.4.3	Application	57
2.4.4	Type of rotary-drum vacuum filter	58
2.4.4.1	Cloth-covered filter	58
2.4.4.2	Coil filter	59
2.4.5	Ancillary equipment	60
2.4.6	Conditioning of sludge	60
2.4.7	Operation	61
2.4.7.1	Start-up	61
2.4.7.2	Routine operation	61
2.4.7.3	Factors affecting operation	61
2.4.7.4	Control tests	63
2.4.8	Maintenance	63
2.4.9	Performance	64
2.4.9.1	Drop-off	65
2.4.9.2	Filtrate	65
2.5	Vacuum disk filter	66
2.5.1	Introduction	66
2.5.2	Design	66
2.5.3	Operation	67
2.5.4	Plant variables	67
2.5.4.1	Conditioning	67
2.5.4.2	Position of chemical injection points	67
2.5.4.3	Speed of mixer	67
2.5.4.4	Speed of disk rotation	68
2.5.4.5	Type of cloth	68
2.5.5	Performance	68
2.6	Filter belt press or band filter	68
2.6.1	Introduction	68
2.6.2	Mechanism	69

2.6.3	Application	70
2.6.4	Design	71
2.6.4.1	Belts	71
2.6.4.2	Draining zone	71
2.6.4.3	Initial compression zone	72
2.6.4.4	Final compression and shear zone	72
2.6.4.5	Types of machine	72
2.6.5	Operation	73
2.6.5.1	Start-up	73
2.6.5.2	Routine operation	73
2.6.5.3	Operational variables	74
2.6.5.4	Control tests	75
2.6.6	Maintenance	76
2.6.7	Performance	77
2.7	Centrifuge	77
2.7.1	Introduction	77
2.7.2	Mechanism	77
2.7.3	Application	78
2.7.4	Nozzle-bowl centrifuge	79
2.7.5	Solid-bowl scroll discharge centrifuge	79
2.7.5.1	Design	80
2.7.5.2	Scroll	82
2.7.5.3	Sludge feed zone	83
2.7.5.4	Floc zone	83
2.7.6	Operation	84
2.7.6.1	Start-up	84
2.7.6.2	Routine operation	84
2.7.6.3	Operational variables	84
2.7.6.4	Control tests	88
2.7.7	Maintenance	88
2.7.8	Performance	89
2.8	Rotoplug concentrator	89
2.8.1	Introduction	89
2.8.2	Operation	89
2.8.3	Performance	90
3.	THERMAL DRYING	92
3.1	Introduction	92
3.2	Rotary-kiln drier	92
3.2.1	Principle of operation	93
3.3	Atritor drier	93
3.3.1	Principle of operation	94

3.4 Nature of final product	95
Appendix 1. Determination of specific resistance to filtration	96
Appendix 2. Theory of coagulation and flocculation	99
Appendix 3. Theory of filtration	103
Appendix 4. A. Clarification: the Sigma theory	109
B. Clarification: the Beta theory	110
Appendix 5. A. Derivation of 'G force' during centrifugation	112
B. Mechanism of scrolling	113
C. Derivation of expression for solids recovery	115
 REFERENCES	 118
 INDEX	 123

FIGURES

	Page
1. Diagram of gravity drainage tube apparatus	15
2. Laboratory apparatus used for gravity drainage tests	17
3. Diagrammatic arrangement of CST apparatus	18
4. WRC standard shear-test stirrer for evaluating strength of flocs	20
5. Correlation between product of specific resistance to filtration (SRF) and sludge solids concentration (SS) against (CST sludge—CST water)	22
6. Simplified apparatus for determining specific resistance to filtration	23
7. Diagrammatic representation of elutriation process	26
8. General arrangement of eductor	29
9. General arrangement of jet wet disperser	30
10. Flow diagram of heat-treatment process	34
11. General arrangement of sludge drying bed	40
12. Cross-sectional view of membrane plate	48
13. Diagrammatic representation of sequence of operation of rotary drum vacuum filter	57
14. Diagrammatic arrangement of coil-spring vacuum filter	59
15. Schematic layout of filter-belt press	69

16. Simplified arrangement of layout of filter-belt press	70
17. Multistage/incremental pressure increase type filter-belt press	72
18. Drum type filter-belt press	73
19. Diagrammatic representation of nozzle-bowl centrifuge	78
20. Diagrammatic representation of solid-bowl scroll centrifuge	79
21. Effect of pond depth on recovery	85
22. Variation on dryness of cake with speed of bowl for a typical sludge	86
23. Effect of sludge feed solids on solids recovery	86
24. Typical polyelectrolyte dosage rates	87
25. Diagrammatic arrangement of a 4-plug sludge concentrator	90
26. Arrangement of rotary-kiln drier	93
27. Simplified diagram of Atritor-drier	94

PLATES

(Between page 50 and 51)

1. Apparatus to determine capillary suction time.
2. General view of sludge drying beds.
3. Mechanical lifting equipment on sludge drying beds (at Galashiels).
4. Side-bar presses at Blackburn Meadows (Sheffield) sewage-treatment works.
5. Overhead-beam press at Walsall sewage-treatment works.
6. Vacuum filters at Parr (St. Helens) sewage-treatment works.
7. View of a coil filter installation.
8. General view of a vacuum disk filter installation.
9. General view of a filter-belt press installation.
10. General view of a solid-bowl scroll discharge centrifuging plant.
11. General view of a Rotoplug concentrator installation.
12. General view of Atritor-drier.

1. Sludge Conditioning

1.1 Introduction

Sludge conditioning is the physical or chemical treatment of sludge to facilitate dewatering. The success of mechanical dewatering has been due largely to the development of chemical conditioning, and some of the more recent dewatering processes depend on particular conditioning systems. Nearly all the installations in the UK use chemicals (e.g. iron salts, lime, aluminium salts, or organic polyelectrolytes) and, because of their increasing cost, it is important to use only the optimum dose. In the past, the degree of conditioning achieved was difficult to assess; however, the capillary suction time apparatus, which is described later, has now enabled operators to determine the optimum dose of chemical more precisely. In turn, proper conditioning results in greater reliability and consistency of the dewatering process.

Anaerobic digestion is sometimes regarded as a form of conditioning but, in fact, does not generally make the sludge any more amenable to dewatering, and is dealt with in *Sewage Sludge I*. However, the process of elutriation after digestion is very effective in reducing the amount of chemical required for conditioning. Thermal conditioning, such as in the heat-treatment process, was used at about 20 sewage-treatment works from about 1968 but few of these plants are in use today.

1.2 Methods of Assessment

Ideally, a laboratory test for assessing the effectiveness of a conditioning chemical should simulate the physical conditions which will occur in the full-scale dewatering process. However, such tests may be complex and time-consuming, and a simpler test is often adequate, at least as a method of preliminary screening. The tests described hereunder are in order of increasing complexity:

- (a) Visual observation by beaker test;
- (b) Gravity drainage test;

- (c) Capillary suction time (CST) test;
- (d) Standard shear test;
- (e) Buchner funnel test—for determination of specific resistance to filtration.

All the tests can be used either for assessing the effectiveness of a single conditioning chemical or for comparing the effectiveness of several different conditioners.

1.2.1 Visual observation by beaker test

The simplest method of assessing the effectiveness of a conditioner, and the approximate dose requirements, is to observe the size of the sludge flocs produced when various quantities of the conditioning chemical are mixed with samples of the sludge. An effective conditioner will, at an appropriate dosage, induce the formation of visible flocs which, in the case of a polyelectrolyte conditioner, might be as large as 10–20 mm across. The flocs might also be seen to separate readily from the water to leave a clear supernatant liquor which can be decanted from the sludge. This is an indication that the sludge has been ‘superfloculated’—a degree of conditioning which is necessary for some types of dewatering device, e.g. the filter belt press.

A typical test is conducted as follows:

A 25-ml burette (or graduated pipette) is filled with a solution of the chemical to be assessed. If this is a polyelectrolyte, the strength of the solution should be 0.1% active material or less. A volume of 100 ml of sludge is placed in each of several (typically six) 250-ml beakers. A small volume of the chemical (say 5 ml) is added to the sludge in the first beaker, and the sludge and chemical are then mixed by transferring the contents of this beaker into an empty beaker and back again several times. Alternatively, the contents can be mixed by a standard laboratory stirrer¹. Progressively larger volumes of the chemical are added to the sludge in the other beakers and followed by the same mixing procedure. The effect of the various doses of conditioner is then observed, the size of the flocs produced and also the extent to which separation of free water occurs being noted. An indication of the optimum dose is given when further additions of the chemical produce no improvement in flocculation.

The limitation of using only visual observations for assessment is that the results cannot easily be quantified and are open to differing interpretation by different operators. Furthermore, the size of the flocs formed gives no indication of their physical strength. Resistance to shear of sludge flocs is an important requirement for successful dewatering by some types of dewatering systems. The results of visual tests must therefore be interpreted cautiously but they often can give useful qualitative indications.

1.2.2 Gravity drainage tube test

This test measures the rate and extent to which a sludge will filter under gravity and it provides a quantitative assessment of the effectiveness of a conditioning chemical. It is appropriate to use a drainage tube for the test when sludge is to be dewatered on drying beds¹ and to use a flat-bottomed filter funnel where the sludge is to be dewatered by a filter-belt press².

Drainage tube. The drainage-tube apparatus (Fig. 1) can be constructed from plastic measuring cylinders (500–1000 ml capacity) of overall height at least 350 mm. The bottom end of one of the cylinders (which is to serve as the drainage tube) is cut off and fitted with a rubber bung, provided with an outlet tube (8 mm dia.) with tap. Another measuring cylinder serves as the filtrate collection vessel.

The drainage tube is fitted with two circular disks of woven wire at its base and is then filled to a depth of about 50 mm with sand (of the same type used in sludge drying beds).

To prepare the bed of sand, tap water is first passed upwards through the tube to expand the bed and grade the sand (coarse particles at the base and finest at the top of the bed). The flow of water is then stopped and the sand allowed to settle and consolidate, the side of the tube being tapped gently to level the upper surface of the bed. The water in the tube is allowed to drain away and this serves as a check that the porosity of the sand is adequate.

The test is conducted by filling the tube to a depth of about 300 mm with the sludge sample to be tested. During filling, care is taken to ensure that the surface of the drainage medium is not disturbed. This is best achieved by using a filling tube and splash plate which are withdrawn immediately the tube has been filled with sludge.

The tap is then opened and the volume of filtrate which collects is measured at appropriate intervals. When the flow of filtrate has ceased, the dry matter content of the filter cake can be determined directly or it can be estimated at any time beforehand from the volume of filtrate collected and the initial solids content of the sludge. The conditioning effect of a chemical is assessed by comparing the rate of filtration of sludges treated with varying concentrations of the chemical.

Filter funnel. In the gravity drainage tube, the depth of sludge applied is about 300 mm, whereas in the gravity drainage stage of a filter-belt press a depth of sludge of about 30 mm only is applied. A laboratory test which simulates these latter conditions can be conducted with a 90-mm Hartley

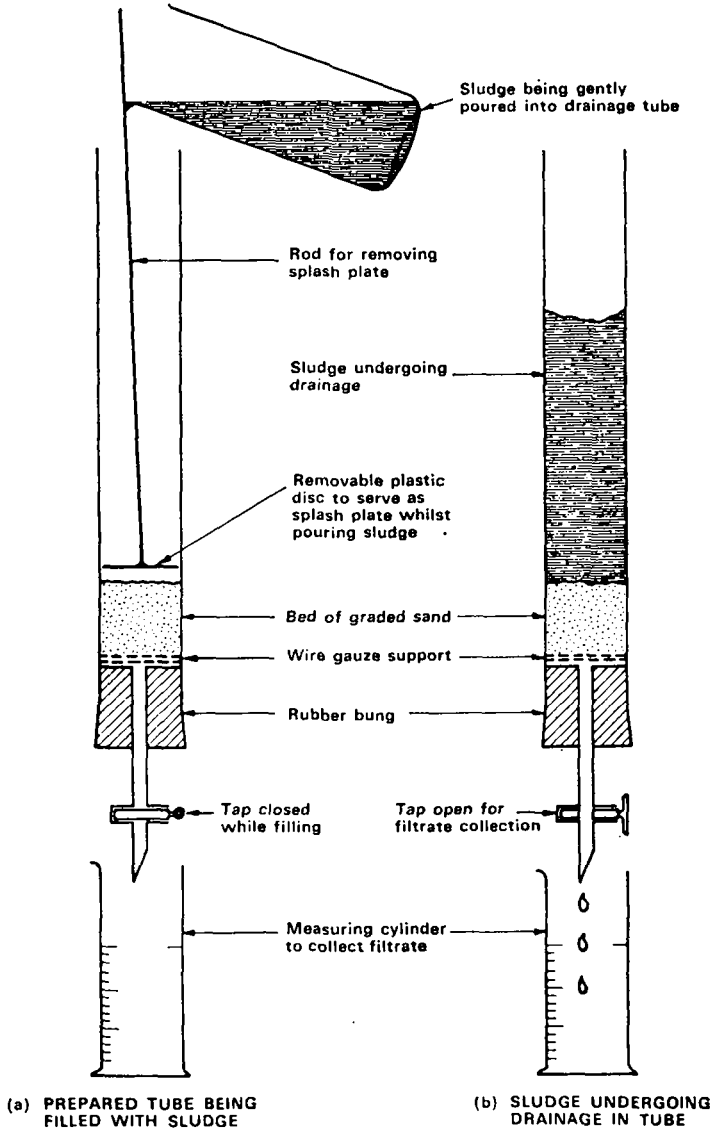

Fig. 1. Diagram of gravity drainage tube apparatus

filter funnel (Fig. 2). The perforated plate of the funnel is covered with (or replaced by) a filter cloth of similar type to that which is used on the full-scale press. In order to prevent lateral leakage of the filtrate through the filter cloth, the annulus of cloth beneath the flanges of the funnel is impregnated with paraffin wax. Filtrate is collected either in a measuring cylinder or in a vessel resting on a top-pan balance so that the weight (and hence the volume) of filtrate collected can be measured at intervals.

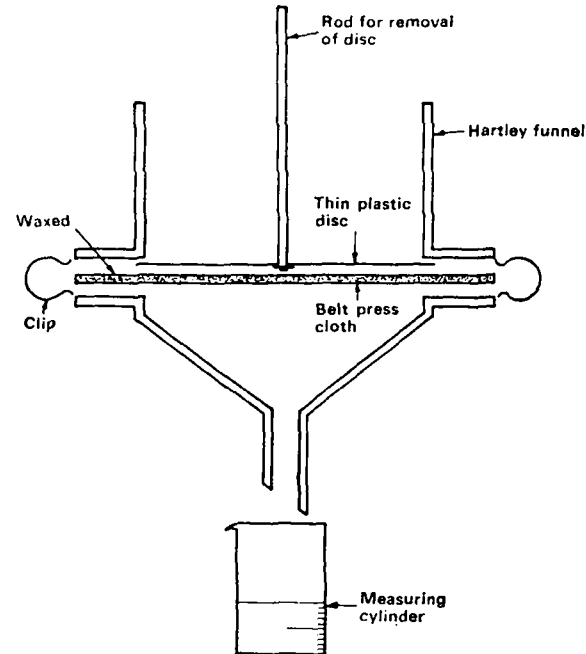

Fig. 2. Laboratory apparatus used for gravity drainage tests.

To carry out the test, a sample of the sludge of volume up to 300 ml is poured gently onto a splash-plate temporarily covering the filter cloth. When all of the sludge has been poured into the funnel, the splash-plate is rapidly removed and the rate at which filtration occurs is measured from the volume of filtrate collected at successive intervals of time. To achieve successful gravity drainage on the first stage of a filter belt press, it is usually necessary for the conditioning chemical to produce the condition of 'super-flocculation'. When this condition occurs, complete drainage will normally require a period of 30 s to 2 min. The test described is therefore completed within a short period.

1.2.3 Capillary suction time (CST) filtrability apparatus (Plate 1, Fig. 3).

The CST apparatus^{3,4} automatically measures the time required for a small volume of filtrate to be withdrawn from a sludge when subjected to the capillary suction pressure of dry filter paper. The CST apparatus comprises 4 items:

- (a) A metal cylindrical sludge reservoir of 18 mm or 10 mm dia.
- (b) A rectangular piece (90 × 70 mm) of dry Whatman No. 17 grade filter paper.
- (c) Two rectangular perspex blocks, the upper one of which has a central hole for locating the sludge reservoir. Embedded into the upper block are three electrical probes, two of which are positioned on a common radial distance from the centre of the block and the third at a greater radial distance from the centre. These probes rest on the filter paper and are used as conductivity sensors to start and stop a timing mechanism.
- (d) A timing mechanism which displays the time in seconds (the CST) taken for the filtrate interface to move radially through the filter paper from the inner (starting) probes to the outer (stopping) probe.

To use the apparatus, the piece of dry filter paper is placed between the two perspex blocks. The sludge reservoir is then eased into the central hole

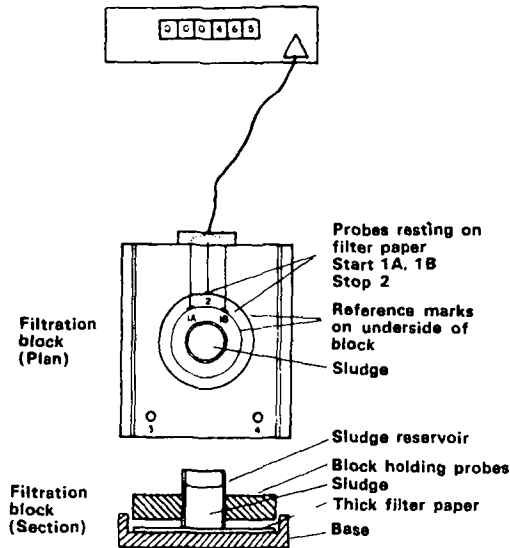

Fig. 3. Diagrammatic arrangement of CST apparatus.

of the upper block so that it rests evenly in the filter paper. A small volume of the sludge under test (typically about 3 ml) is poured into the reservoir; the actual volume of sludge is not important as the hydrostatic head of sludge is minimal compared with the suction pressure exerted by the capillaries within the paper. Immediately the sludge comes into contact with the surface of the paper, a flow of filtrate into the paper commences and forms an approximately circular interface of progressively increasing diameter. When the filtrate interface reaches the inner probes, the timing clock starts and when it reaches the outer probe the clock stops—the interval of time being the capillary suction time.

For fast filtering sludges the 10-mm reservoir is preferable, whereas for sludges with normal filtration rates the 18-mm reservoir should be employed. The CST of water alone is usually about 4 s for an 18-mm reservoir and about 8 s for a 10-mm reservoir.

The effectiveness of a conditioner is assessed by measuring the CST of separate samples of sludge to which have been added varying quantities of chemical. The lower the CST the more readily the sludge filters. When various chemicals are being compared as conditioners, the one which reduces the CST to the greatest extent will, in general, be the most effective (but not necessarily the most economical) conditioner for that particular sludge.

1.2.4 Standard shear test

In addition to performing CST determinations on samples of conditioned sludge, it is often desirable to assess the physical strength of the conditioned sludge flocs. This is achieved by subjecting the sludge to high-speed stirring for various periods and measuring the changes in CST brought about by the different degrees of imposed shear. A sludge with strong flocs will show relatively little change in CST after stirring whereas a sludge with weak flocs will show a significant increase in CST even after a short period of stirring.

The shear test has now become standardized and forms the basis of a European recommended method for assessing the conditionability of a sewage sludge⁵.

The test is carried out by adding various quantities of a solution of the conditioning chemical (made up to a standard 20-ml volume with water in each case) to 100 ml volumes of the sludge in a 250-ml beaker whilst stirring the sludge with a standard laboratory stirrer (Fig. 4)^{4,6} for 10 s. After stirring, the sludge is poured into another 250-ml beaker and then back again. The sludge is then poured immediately into the reservoir of a CST apparatus and

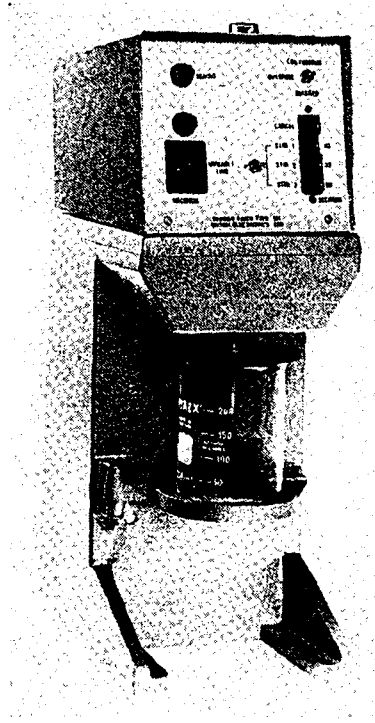

Fig. 4. WRC standard shear-test stirrer for evaluating strength of flocs.

the CST noted. The remainder of the sludge is then stirred for a further period of 10 s, poured between two beakers, and then into a CST reservoir. The procedure is then repeated twice using periods of stirring of 30 s and 60 s respectively.

A control test is carried out with the initial addition of 20 ml of water only to 100 ml of the sludge.

A typical set of results is shown in Table 1. It is seen that only with the highest dose of chemical (5.2 kg/tonne) was the sludge floc sufficiently strong to withstand the shearing force of the stirrer—there being no increase of CST after stirring for 10 s and 30 s. Indeed, after the initial 10 s stirring period the CST decreased from 15 to 12 s. This is indicative that there was an initial excess of unadsorbed polyelectrolyte.

It has been shown that the shear imposed on a sludge as it is pumped into a filter press is about the same as the shear produced by stirring for 40 s in

TABLE 1. EFFECT OF VARYING DOSAGES OF POLYELECTROLYTE ON FILTRABILITY OF A RAW SLUDGE**(Total solids 5.0% DS after addition of conditioner)**

Dose of polyelectrolyte		Total stirring period (s)				Specific resistance † to filtration (after stirring for 40 s) (10 ¹² m/kg)
		0	10	40	100	
Concentration (kg/tonne DS)	Cost* (£/tonne DS)	CST (s) (18 mm reservoir)				
0	0	214	226	229	235	200
0.33	1	45	60	82	104	40
0.65	2	22	34	54	70	20
1.3	4	17	25	34	57	10
2.6	8	8	12	18	21	3
5.2	16	15	12	12	15	1.5

*At 1981 prices

†Specific resistance values obtained from the calibration graph Fig. 5.

the standard laboratory stirrer⁴. Thus in Table 1, the CSTs of the sludge samples stirred for 40 s are the CSTs which are likely to have been obtained within a full-scale filter press if the same doses of chemical had been used when the sludge was dewatered on a full-scale filter-pressing plant. For a sludge containing 5% DS, a CST (18 mm) of 20 s is often regarded as the maximum acceptable if one filter pressing per day is to be achieved⁷. From Table 1, a dose of polyelectrolyte of about 2 kg/tonne would be required to achieve a CST of less than 20 s after a shear equivalent of 40 s stirring.

One of the filtration characteristics required of a sludge being dewatered by filter-belt press, is that it should drain under gravity rapidly to form a reasonably firm cake². An indication of this degree of filtrability being achieved is given when the CST (18 mm) of the sludge immediately after addition of a conditioning chemical is very low and approaching that of water only, i.e. less than 10 s. From Table 1, this would correspond to a dose of 2.6 kg/tonne.

Results of CST determinations may have considerable significance on their own. An adequately conditioned sludge of 5% DS has a CST of less than 20 s whereas an unconditioned sludge of the same solids content would probably have a CST of 200 s or more. However, for the prediction of performance of a filter press or vacuum filter⁸ the CST results would have more value if they were converted into the absolute filtration parameter—the specific resistance to filtration (see Appendix 1). This conversion is most

easily achieved by means of a calibration graph of the product of specific resistance and solids concentration against CST on a logarithmic scale. In order for the calibration curve to be linearized, the product of specific resistance and suspended solids concentration should be plotted against the CST of the sludge *minus* the CST of water⁹. An example of a calibration graph is given in Fig. 5. The advantage of quoting specific resistance values is that theoretically the results should be independent of sludge solids concentration, and this means that valid comparisons can be made between the filtrability of sludges with different solids concentration.

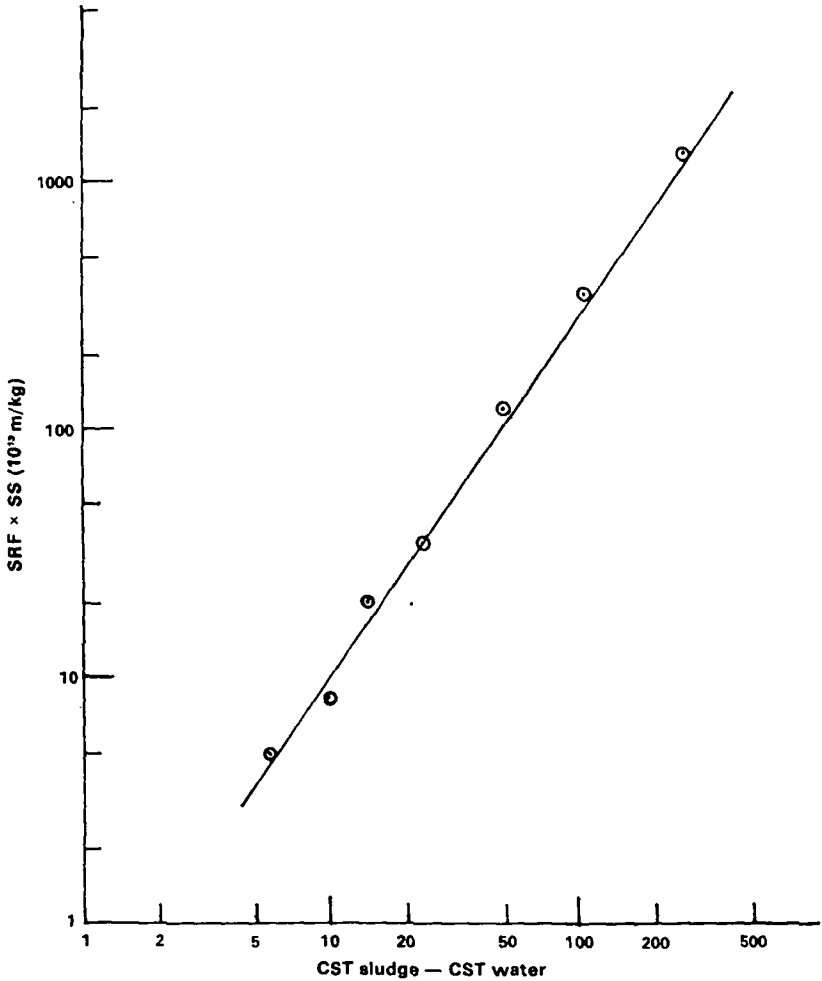

Fig. 5. Correlation between product of specific resistance to filtration (SRF) and sludge solids concentration (SS) against (CST sludge—CST water).

1.2.5 Buchner funnel apparatus for determination of specific resistance to filtration

A simple version of the apparatus (Fig. 6) can be constructed from standard laboratory equipment⁴. It consists of a 70 mm dia. Buchner funnel connected to an evacuated measuring cylinder or burette into which the filtrate flows. The required degree of vacuum (usually 49 kPa) is achieved by adjustment of the variable leak into the vacuum reservoir which is evacuated at a constant rate by a water-operated vacuum pump. A more complex technique for setting the degree of vacuum utilizes a mercury manostat⁴.

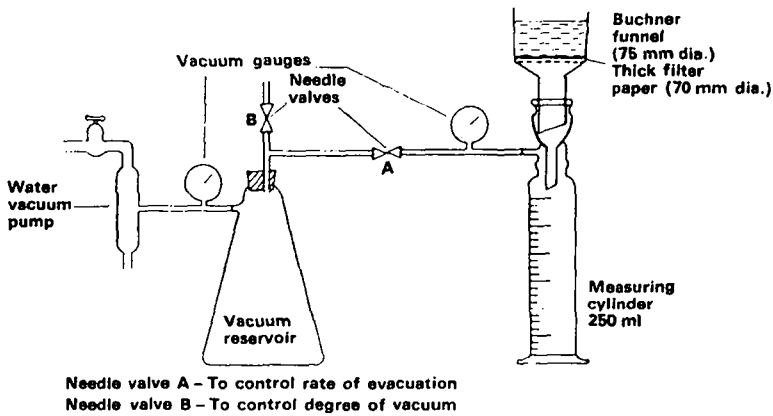

Fig. 6. Simplified apparatus for determining specific resistance to filtration

The degree of vacuum (49 kPa) is first set by adjustment of valve B with valve A closed. The filter medium (which may be a Whatman No. 17, or 3 layers of Whatman No. 1, 70 mm dia. filter paper) is placed in the funnel and wetted with a little water. With the funnel connected to the measuring cylinder, valve A is opened slightly to remove the surplus water and to ensure the filter medium fits closely to the bottom of the funnel. About 300 ml of the sludge are then transferred between beakers to ensure adequate mixing, and a subsample of 100 ml is taken for subsequent total dry solids determination. At least 100 ml of the remainder of the sludge sample are then poured into the Buchner funnel. With valve A already slightly open, gauge 1 should immediately indicate that a pressure difference is being applied to the sludge, and filtrate should be allowed to flow into the measuring cylinder. (When there is no indication of a change in pressure it is probably due to a leak in the system; this should be remedied.) Valve A is then gradually opened further so that the required degree of vacuum is reached within about 30 s. During

this period some adjustment of valve B may be necessary to maintain the required degree of vacuum, particularly if the rate of filtration is rapid.

The rate of filtration is then measured by recording the total volume of filtrate collected after various time intervals. The intervals of time do not necessarily have to be constant but may be progressively increased to compensate for the gradual decrease in the filtration rate. Typically between 5 and 10 volume and time measurements are adequate. Throughout the period of observations it is necessary to ensure that the pressure of filtration remains constant.

Finally, after valve A has been closed and the residual vacuum in the system released, a sample of filtrate is taken for the determination of total solids concentration. This figure will approximate to the dissolved solids concentration of the sludge, which on subtraction from the sludge total solids will approximately equal the sludge suspended-solids concentration.

On removing the Buchner funnel for cleansing, check that there is a surplus of sludge covering the filter cake. If there is none it is necessary for the determination to be repeated, but using an increased volume of sludge. This may necessitate the fitting of a cylindrical extension piece to the top of the Buchner funnel.

An example of a calculation to determine the specific resistance to filtration is given in Appendix 1.

1.3 Elutriation

1.3.1 Introduction

Elutriation has been defined¹⁰ as a conditioning process in which sludge is washed with either fresh water or plant effluent to reduce the alkalinity of the sludge, particularly by removing ammoniacal compounds. The process reduces the amount of chemical coagulant needed to condition the sludge for mechanical dewatering. Although elutriation is now used primarily for the reduction of alkalinity of anaerobically digested sludge, and not for the classification of solids, inevitably some fine suspended solids are removed and, if not controlled, these can impose an additional load on the treatment plant. At the Long Reach sewage-treatment works¹¹ (near Dartford) the removal of these fine suspended solids from the sludge is an important part of the process.

Elutriation was first used in the USA before 1940 and since then experimental work has been carried out in this country. A number of installations were built in the 1940s and 1950s, including that at Long Reach, but more recently plants have been built or extended at Andover, Chesterfield, Mansfield, St. Helens and Basildon and renewed interest is being shown in the process. A description of the process and the plant in use at the Long Reach sewage-treatment works is given in a working party report¹¹.

1.3.2 Mechanism

In the sludge digestion process, much of the complex nitrogenous material present in the raw sludge is degraded and simpler alkaline ammonium salts are formed. There is also an increase in the amount of fine suspended solid matter and a considerable increase in the bicarbonate alkalinity of the sludge which needs to be neutralized before some chemical conditioners become effective.

Elutriation is essentially a washing process and its efficiency depends on the degree of dilution. The digested sludge is mixed with three to five times its own volume of elutriant, usually plant effluent or primary sedimentation tank effluent, and the mixture is allowed to settle. The supernatant liquor, the elutriate, carries away the soluble degradation products of digestion to the works' inlet. The sludge retained in the tank is allowed to consolidate and is then passed forward to the next stage of conditioning and dewatering. If the consolidation stage is prolonged, digestion could continue and partially negate the advantages of elutriation.

1.3.3 Application

The elutriation process has nearly always been applied to digested sludge and is regarded as a conditioning process in itself to precede mechanical dewatering. Elutriation tanks often take the place of conventional secondary sludge digesters and the rapid cooling effect provided by dilution with the plant effluent is a considerable advantage to consolidation.

1.3.4 Design and operation

The object of the operation is to transfer soluble alkaline products from the digested sludge to the elutriate and to retain within the elutriation tank the maximum amount of solids for consolidation. At Long Reach sewage-treatment works, however, where vacuum filtration follows elutriation, it is also used for the classification of solids. Normally, elutriation is a continuous process and the sludge and wash water can be measured and controlled

automatically; the elutriation tank also serves as a consolidation tank for which purpose it is usually equipped with a picket fence thickener. At Mansfield¹², the hydraulic loading of the elutriation tank is $3 \text{ m}^3/\text{m}^2 \text{ d}$ and the solids loading $80 \text{ kg}/\text{m}^2 \text{ d}$: the performance has been shown to be satisfactory. The thickened sludge is stored in the central hopper prior to chemical conditioning and dewatering and the elutriate passes over the outlet weirs and is returned to the works' inlet. A diagrammatic representation of the process in use in the UK is shown in Fig. 7.

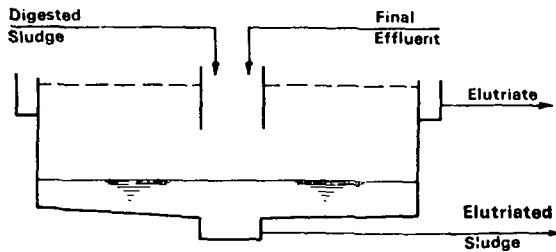

Fig. 7. Diagrammatic representation of elutriation process.

The mechanical equipment used is well established in sewage works practice and does not need extra attention. The effectiveness of the process is measured by the change in conditioner demand, and bench tests are also carried out to measure the bicarbonate alkalinity of the sludge before and after elutriation. In addition, the SS content and BOD of the elutriate are measured to assess the additional load on the plant.

1.3.5 Performance

The bicarbonate alkalinity of the sludge may be reduced from over $4500 \text{ mg}/\text{l}$ to $2000 \text{ mg}/\text{l}$ and after elutriation the conditioner demand of the digested sludge may be halved. Table 2 gives examples of typical analyses of elutriates.

TABLE 2. TYPICAL ANALYSIS OF ELUTRIATES
Results of analysis expressed as mg/l

	BOD	COD	SS	Amm.N.	Alkalinity
Chesterfield ¹⁹	300	—	300	—	—
Long Reach ¹⁴	950	2100	2000	150	—
Mansfield ¹²	430	1000	470	130	930

1.4 Chemical Conditioning

1.4.1 History

In the early days of sewage treatment, various chemicals were added to sewage to facilitate the separation of solids, and the same types of chemicals were used when the first sludge dewatering machines were introduced in the mid-nineteenth century. The most common chemical used was lime, as it had the added advantage of suppressing malodours and making the sludge more acceptable for land disposal. Following the introduction of the activated-sludge process, it was found that lime alone was not capable of satisfactorily conditioning the surplus sludge, either alone or in admixture with primary sludge. Other chemicals, e.g. iron or aluminium salts, were used in conjunction with the lime, which improved the performance of the dewatering plant. The chemical most commonly used was copperas, i.e. ferrous sulphate, which was sometimes used as a chlorinated solution. The use of lime and copperas has continued up to the present, although since the early 1950s aluminium chlorohydrate has also been employed or replaced the use of these owing to the greater ease of handling and the improved performance. With the introduction of polyelectrolytes around 1967, new sludge dewatering techniques have developed, e.g. centrifuges and belt presses, which depend upon the exceptional conditioning capabilities of these compounds.

1.4.2 Lime and copperas

Lime is nearly always used in conjunction with copperas, but if iron salts are present in the sewage, in sufficient concentration, lime can be used alone¹⁵. The main use of lime and copperas is for conditioning sludges to be dewatered in filter presses.

Tests will be required to determine optimum doses for individual sludges, but typically the concentrations of lime (Ca(OH)_2) and copperas ($\text{FeSO}_4 \cdot 7\text{H}_2\text{O}$) required for satisfactory conditioning are, respectively, 20% and 10% for raw sludges, and 30% and 40% for digested sludges, based on dry solids. For most effective conditioning it is usual to add copperas before the lime.

Lime has the advantage that it increases the pH value of the sludge and thus suppresses the emission of hydrogen sulphide and other malodours. However, as a result of the high pH value, ammonia is usually evolved and therefore adequate ventilation must be provided. The presence of lime in the cake may also increase its acceptability to farmers, particularly where lime would otherwise need to be purchased for soil conditioning; the high pH value of the cake also reduces the number of pathogenic bacteria. A disadvantage of adding lime and copperas is the significant increase in the weight

of solids for disposal. The presence of these inert chemicals also significantly reduces the calorific value of the cake, but this is only a disadvantage if the sludge is to be incinerated.

Lime is normally delivered in bulk and stored in a silo; if bags have to be used they must be kept dry. At larger works it may be more economical to use quicklime which can be slaked on site.

Copperas is delivered in a crystalline form and dissolved on site. Owing to the corrosive and highly acidic nature of the solution, the storage tanks must be of corrosion-resistant materials; stirring equipment should be made of stainless steel, and pipework, valves etc., must also be chemically resistant. Protective clothing must be worn by all operators handling copperas solutions.

1.4.3 Aluminium chlorohydrate

Aluminium chlorohydrate, which was introduced to the UK in the early 1950s, is supplied as an aqueous solution containing a maximum of 15% w/w Al_2O_3 . It is most commonly used as a conditioning agent for sludge to be dewatered in filter presses, rotary vacuum filters and on drying beds.

Aluminium chlorohydrate has the advantage that it requires diluting only prior to use and does not add significantly to the mass of the sludge cake. Actual coagulant demand depends upon the nature of the sludge and the method of dewatering.

Where it is necessary to control the emission of sulphides and other malodours into the atmosphere of the dewatering building, aluminium chlorohydrate is used in conjunction with 5–10% lime.

Aluminium chlorohydrate solution, as delivered, requires a 10–20 fold dilution before use. Care should be taken in handling as, being acidic, it can cause irritation to eyes, open cuts and mucous membranes. Suitable protective clothing should be worn.

The diluted aluminium chlorohydrate solution is added to the sludge either on a batch basis or 'in line'. The latter method, which is more recent, involves direct injection of a controlled dose into the pipeline feeding sludge to the dewatering machine. This technique eliminates the need for a separate sludge conditioning tank, and because of the improved mixing and reduced shear of the conditioned sludge, the chemical requirement is minimized.

1.4.4 Polyelectrolytes

Polyelectrolytes can be supplied in either liquid, granular or powder form. Liquid forms are the easiest to handle but are not suitable for all applications.

Where powdered or granular grades have to be used, they require dispersion in water before use. The resulting suspension must be allowed to 'solubilize' or 'mature' (sometimes referred to as 'ageing').

Polyelectrolytes were introduced to the UK in the mid 1960s and rapidly became identified as being suitable for use with centrifuges. They have also been used for conditioning sludge prior to dewatering in filter presses, but their main application is conditioning sludge in filter belt press plants. Typical dosage rates for raw sludge are 2–5 kg/tonne for centrifuges and 1–4 kg/tonne for belt presses, and therefore there is no significant increase in the mass of sludge solids for disposal. Polyelectrolytes can be used in conjunction with lime, which suppresses the evolution of hydrogen sulphide and other malodours. More recently hydrogen peroxide has been used to control sulphide emissions.

Polyelectrolytes, as supplied in the liquid form, usually contain 15% active ingredient and are diluted before use to 0.1–0.25% active material. Once diluted, the solution can be used immediately. However, it is not advisable to prepare a volume greatly in excess of demand as the conditioning capability deteriorates with storage. No special precautions need to be taken in handling liquid polymers, but care should be taken to avoid splashing into the eyes. The main hazard in handling is if any is spilled onto a floor: even small amounts can make the surface very slippery.

Some powdered or granular polyelectrolytes dissolve only with difficulty and normally it is necessary to use either an eductor or a special wet dispersal unit. An eductor (Fig. 8) consists of a water vacuum pump fitted with a funnel and connected to a high-pressure water supply. The polymer is placed in the funnel and is drawn into the vortex by the vacuum, causing it to be dispersed in the water. In the wet dispersal unit (Fig. 9) the polymer is carried in air

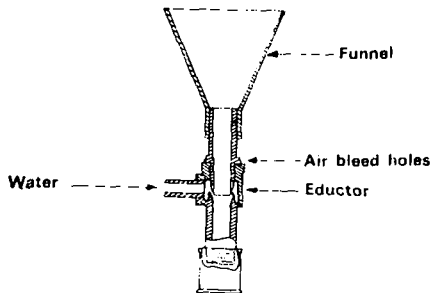

Fig. 8. General arrangement of eductor

SLUDGE CONDITIONING

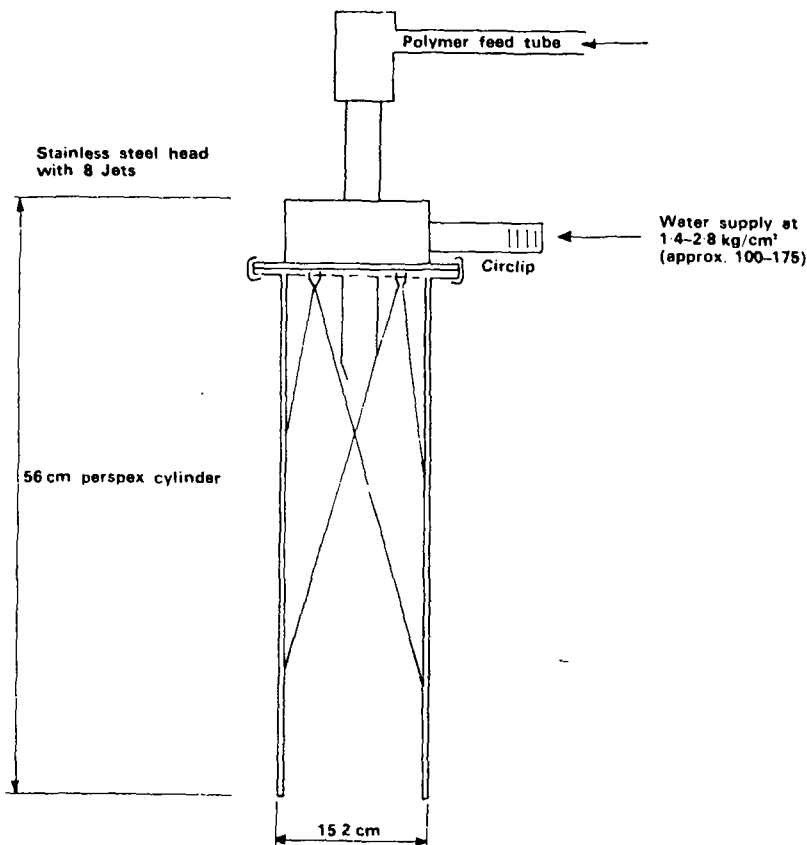

Fig. 9. General arrangement of jet wet disperser.

into a high-pressure water spray. As the polymer is already dispersed in the air flow, it is easier to disperse it into the water.

Powdered or granular polymers should never be added directly into the water tank as only gelatinous 'globs' will be formed. Powdered polymers, which should be stored in dry conditions, are commonly prepared as a 0.1-0.5% working solution. All mixtures need to be 'aged', typically for about 2 h, after preparation to ensure that the dispersion becomes a solution. However, their effectiveness deteriorates with prolonged storage. In hard-water areas, a 0.1% solution can begin to deteriorate within a few hours, whereas solutions of 0.5-1.0% are stable for several days. In hard-water areas it may be more appropriate to use softened water for the preparation of solutions.

When handling powdered polyelectrolytes, precautions need to be taken to prevent inhalation of the dust and irritation of the eyes. Extreme care must be taken to prevent spillages of the powder, because when it becomes wet a slippery gelatinous layer is formed which can be removed only by washing with copious volumes of water.

It has been found that the higher the shear imposed on the sludge flocs, the greater should be the molecular weight of the polymer. Thus a polymer which is used to assist dewatering on drying beds does not need to have a high molecular weight. Conversely, polymers which are used for conditioning a sludge to be centrifuged need to have high molecular weights to produce large tenacious flocs capable of withstanding high shearing forces and of inducing rapid solid-liquid separation.

Polyelectrolyte doses can be expressed as either:

- (i) Weight of active ingredient added per weight of sludge dry solids (kg/tonne DS) or per cent
- (ii) Volumetric (gm/m³ sludge)

The dose rate in (i) can be calculated from:

$$\text{Dose} = \frac{S_p \cdot Q_p}{S_f \cdot Q_f} \times 1000 \text{ (kg/tonne DS in feed)}$$

where S_p = Strength of polyelectrolyte solution
(kg active ingredient/kg)

Q_p = Dose rate of polyelectrolyte solution
(kg of solution/h)

S_f = Dry solids content of feed sludge
(kg/kg)

Q_f = Wet sludge feed rate (kg/h)

Owing to the wide range of price of polyelectrolytes, and their effectiveness, the economic dose concept is often used, i.e. the cost of polyelectrolyte per tonne of dry solids (£/tonne DS), for equal performance.

1.4.5. Factors affecting coagulant demand

1.4.5.1 Type of sludge. Owing to its fibrous nature, a primary sludge is far easier to condition than a digested or secondary sludge. Secondary sludges from high-rate processes are most difficult to condition.

1.4.5.2 Period of storage. A fresh raw sludge needs less coagulant than one that has been stored for several days. The older the sludge the higher the coagulant demand.

1.4.5.3 Mixing. The method of mixing coagulants into the sludge can greatly affect their performance and therefore the amount required. All mixing needs to be thorough but not violent as this will tend to break down, i.e. shear, the sludge flocs. When using lime and copperas, mixing tanks are usually provided into which the sludge and chemicals are introduced, and stirrers are incorporated to ensure a complete mix of both chemicals and sludge. Systems using polyelectrolytes which adsorb rapidly generally utilize the 'in-line' method of addition; this means that the chemical is injected into the sludge feed line, thus dispensing with conditioning tanks. With 'in-line' mixing, the best results are obtainable if the sludge feed is constant in both flow and consistency; this can be achieved using a stirred sludge-holding tank. A further advantage of 'in-line' dosing is that it virtually eliminates the period of storage of the sludge.

1.5 Thermal Conditioning

1.5.1 Introduction

It is generally acknowledged that the use of heat treatment, comparable to the present-day process, was first developed by W. K. Porteous, and installations using his design were commissioned at Halifax and Horsham in 1939¹⁶. Later, the process was used at a number of other sewage works in order to condition sludge, as a preliminary to dewatering. This method of sludge conditioning in the absence of air became known as the Porteous' or heat-treatment process¹⁰. Raw sludge was forced by a ram pump through a heat exchanger and the temperature raised to 160°C before being forced against stream pressure into a reaction vessel, where the temperature was maintained at 185°C for about 30 min. From the reaction vessel sludge was returned, countercurrent, through the heat exchanger to settlement tanks where the supernatant liquor was removed. It was a batch process and, at any time, one reactor was being filled, another being emptied and another in use¹⁷. Subsequently the process was developed as a continuous-flow system and this formed the basis of the 20 to 30 installations around the UK in the late 1960s and early 1970s¹⁸⁻²¹. The process of thermal conditioning in the presence of air (Wet-Air Oxidation) was first developed in the USA as the Zimpro Process and the first installation in the UK was at Guildford in 1972.

Thermal conditioning has a number of disadvantages which include the emission of strong odours and the production of a strong, highly-coloured

liquid which is difficult to treat in normal sewage-treatment processes and is only partly biodegradable. Despite its high effectiveness as a conditioning process, these disadvantages, together with the high cost of operation and maintenance, have caused the number of plants in use in the UK to decline sharply.

1.5.2 Types of plant and application

There are three types of thermal conditioning process operating at temperatures ranging up to 250°C with a correspondingly high pressure. The major difference between them is the amount of air introduced into the system which determines the amount of organic matter oxidized.

1.5.2.1 Heat treatment process. The process was developed from earlier patents in the 1930s as a batch process named after its developer, W. K. Porteous. The later generation of heat-treatment plants were designed to achieve continuous flow with a temperature of 190°C. No air is introduced to the system and no oxidation of the sludge occurs.

1.5.2.2 Zimpro process. This was developed in the USA in 1954, and the only plant in the UK was commissioned at Hockford near Guildford in 1972. It was described as a high oxidation process because it was expected that 65% of the organic matter would be oxidized. In order to achieve this degree of oxidation, sufficient air was introduced into the sludge before it entered the heat exchanger. The sludge in the reaction vessel was maintained at a temperature of 250°C for about 30 min. Under these conditions the process was exothermic and the product had a high ash content with a much reduced volume.

1.5.2.3 Thermal conditioning with air. In this variation of the Zimpro process, less air is introduced than for complete oxidation, only 15% of the organic matter is oxidized and the operating temperature is about 200°C. The process was installed at Thurrock in 1975 though it is no longer in use; and also at Crewe in 1976, where it remains operational.

1.5.3 Principle of process

The thermal conditioning process destroys the affinity between sludge particles and water, and facilitates their separation. In addition, the heat causes the cell walls to rupture, releasing the intracellular material, and there is a significant amount of solubilization of protein. The solid and liquid phases then separate rapidly on cooling. Thermal conditioning is generally acknowledged to be the most effective of all conditioning systems, and the

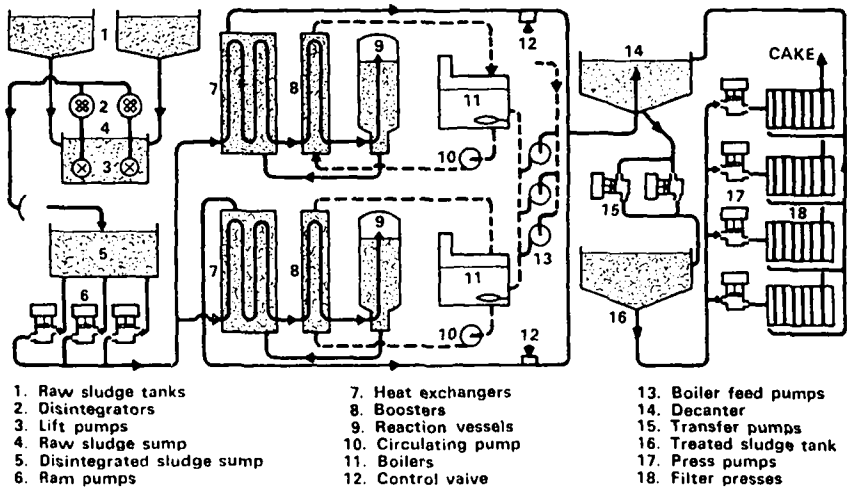

Fig. 10. Flow diagram of heat-treatment process.

volume of thickened sludge which is produced is much less than that produced using conventional chemical conditioning systems. The conditioned sludge is able to resist shear and compression during any subsequent dewatering process and, in addition, the pathogen counts are greatly reduced. Figure 10 illustrates the flow pattern of a heat-treatment installation.

1.5.4 Operation

1.5.4.1 Preliminary treatment. It is essential that the sludge is free from rags and grit. Although the preliminary sewage-treatment processes would include screening, it is advisable, even after disintegration, to provide fine screens; these are to protect the pumps, which form an integral part of the process, and also to minimize blockage within the heat exchanger and pipe-work.

1.5.4.2 Heating and recovery. The method of heating and of heat recovery is essentially similar in all installations, though there are variations in detail according to the degree of oxidation required²²⁻²⁵. The untreated sludge, which has previously been screened and thickened, is pumped into the pressure system and then, according to the level of oxidation required, a quantity of air is injected before the sludge enters the heat exchangers. No air is required for the normal heat-treatment process. The temperature of the sludge passing through the centre tube of the heat exchanger is raised by the

transfer of heat from the outer annulus, in which either water or conditioned sludge is circulated. The final stage of raising the temperature to that required for the reaction is achieved by using superheated water in the annulus, or by steam injection. When the required temperature has been reached, the sludge is held in the reaction vessel for about 30 min. The fully conditioned sludge is then returned to the heat exchanger to cool, leaving the system through a pressure control valve where the pressure is reduced to that of the atmosphere.

1.5.4.3 Continuous flow settlement. When fully conditioned, the sludge is a free-flowing dark brown liquid with black, readily-settleable sludge particles. The sludge is discharged through the pressure control valves at a temperature of about 60°C and enters a decanter where it cools and settles rapidly.

The supernatant liquor, which is usually returned to the sewage-works inlet, frequently has a BOD in excess of 8000 mg/l. At some sewage works, high-rate biological filters are installed to provide pretreatment of the liquor to minimize the effect on the treatment processes. A significant part of the load from the heat-treatment process is non-biodegradable and passes through the sewage works to the receiving watercourse.

1.5.4.4 Odour nuisance. Sludge should be cooled by heat exchange to the lowest practicable temperature because, during cooling in a tank, it emits a strong, offensive odour which can give rise to complaints. Problems can be minimized by directing all the gases from within the buildings and from under the covers of the settlement tanks, to a point of treatment which may incorporate, for example, a catalytic furnace.

1.5.5 Maintenance. A thermal conditioning plant comprises complex units having a number of critical operations and control circuits. Failure of any one of these can result in the closure of other sections. It is essential, therefore, that there is a high degree of preventative maintenance, and the lack of this at some installations has contributed to a general reputation of unreliability. The more common causes of failure have included wear of the pumps, erosion of the heat-exchange tubes, cavitation, blockage of the annular spaces, scale formation on the tubes and failure of the pressure control valves. It has been found that the heat exchanger must be cleaned frequently in order to minimize the risk of blockage or scale formation. On later installations, water replaced sludge in the outer annulus of the heat exchanger and this prevented the accumulation of debris and scale. At many installations a solution of an inhibited acid was periodically pumped through the heat

exchanger. More recently a "pig" has been devised which can be passed through the system, or a form of cathodic protection has been provided to reduce scale formation.

Grit, particularly in primary sludge, can cause considerable wear to pumps and valves in the system and also contribute to blockage and erosion of the pipework.

It has been the general experience that the operation and maintenance of the heat-treatment plant, usually in conjunction with other sludge treatment processes, requires a high level of supervision.

2. Sludge Dewatering

2.1 Introduction

Sludge dewatering may be defined as the removal of water from sludge to form a cake which generally contains more than 15% dry solids. It achieves a considerable reduction in the volume of sludge for disposal, and experience has shown that the cake is more easily handled when it contains more than 20% dry solids.

Sludge dewatering is only a part of the process of sludge treatment and disposal; it is usually preceded by thickening and conditioning, and may be followed by further treatment.

In the late 19th century, sludge was dewatered in simple lagoons, sometimes having underdrainage, until it was spadeable. It was then stacked nearby for further drying to take place before final disposal. Later, in order to reduce the labour requirement and to speed the operation, elaborate lifting machines were developed.

Sludge drying beds and filter presses operated satisfactorily with primary and co-settled primary and humus sludge, but the introduction of the activated-sludge process in the 1920s resulted in the production of greater quantities of sludge, which were much more difficult to dewater. During the late 1930s the vacuum filter was developed and then, 30 years later the filter belt press and, to a more limited extent, the centrifuge.

The success of mechanical dewatering, apart from design improvements, was largely due to the development of chemical conditioners. The most common chemical used until the early 1960s was lime in conjunction with iron salts. In 1953 aluminium chlorohydrate was introduced and in the late 1960s polyelectrolytes had a profound effect upon the development of alternative dewatering equipment.

During the 100 years or so of sludge dewatering, the process had developed with the advancement of technology. The filter press, formerly requiring

considerable physical effort, frequently in foul conditions, has become mechanized, alternative dewatering devices have been developed and the conditioning systems have evolved to sophisticated in-line dosing systems.

2.2 Drying Beds

2.2.1 Introduction

In the early years of this century, the use of drying beds was quite widespread as a means of dewatering sludge. However, with a changing situation, particularly in relation to regional and area disposal strategies, drying beds became less attractive and have been abandoned at many works in favour of the application of liquid sludge to land.

A sludge drying bed (Plate 2) is a shallow tank with a system under-drainage overlaid with filtering media. Liquid sludge is discharged onto the surface of the medium and dewatering occurs as a result of water entering the under-drainage system. Water is also removed from the surface by decantation and evaporation.

The layout and construction of sludge drying beds are variable, but are mainly influenced by the method of removal of cake, i.e. by hand or by machine. The drainage tile system is usually covered with a layer of pea gravel, 100 mm thick, and this is topped by a layer of sand, 25-mm thick, which is replenished when required. A single application of sludge is made to a depth of 300 mm and drainage liquor is carried from the drying beds by the under-drainage system for return to the works inlet.

2.2.2 Mechanism

When liquid sludge is applied to a drying bed, dewatering takes place partly by drainage, partly by decantation of supernatant liquor, and partly by evaporation. The proportions in which liquor is removed by each of these ways depends upon:

- (a) the character of the sludge;
- (b) its initial solids content;
- (c) the period of drying;
- (d) the porosity of the bed; and
- (e) weather conditions.

Table 3 gives the results of experiments which were carried out by the Water Pollution Research Laboratory^{26,27} when (a) raw sludge, (b) digested

TABLE 3. REMOVAL OF LIQUOR FROM SLUDGES APPLIED TO PILOT-SCALE DRYING BEDS
(per cent of total liquor)

Proportion of liquor removed by	Raw sludge (a)	Digested sludge drainage characteristics	
		Poor (b)	Good (c)
Drainage	48-52	28	72
Decantation	4- 9	22	2
Evaporation	43-44	50	27

sludge with good drainage characteristics were applied to pilot-scale drying beds.

When sludge is first applied, the rate of drainage is normally rapid. During the next two or three days the rate progressively decreases, partly because of solid matter which becomes compacted on the surface of the media, offering resistance to filtration. Following the removal of supernatant liquor by decantation, evaporation becomes important and during the initial stages of dewatering, the rate of evaporation is similar to that from a free water surface. Evaporation is affected by wind conditions, humidity and solar radiation.

Eventually in the dewatering process a stage is reached when the sludge starts to crack and as these cracks extend deeper into the layer of sludge the surface exposed to evaporation increases. When the cracks extend to the surface of the media, rain falling on the sludge drains through, so that dewatering is no longer affected to any great extent by rainfall. This is normally the earliest stage at which the sludge is liftable.

2.2.3 Preliminary treatment of sludge

At some works no preliminary treatment is given but in many cases the sludge is screened or disintegrated, digested or chemically conditioned.

Aluminium chlorohydrate or polyelectrolytes are often used to relieve overloading of beds or to improve the drainage characteristics. Since aluminium chlorohydrate was first introduced, full-scale experiments have been carried out on a number of sewage works to determine the optimum dose. This varied between 0.5 and 3.0% Al_2O_3 on dry solids for mixed sludges. The most effective dose of chemical conditioner at a particular works will be found by experiment (see section 1.4.3).

2.2.4 Design

2.2.4.1 Area of beds. The surface area of drying beds required is related to the population served, or to the population equivalent¹⁰. Factors to be considered include: (a) the volume and dry solids content of the sludge; (b) the filtrability, and (c) the average rainfall of the area.

For many years the required area was assumed¹¹ to be 8 persons/m² for primary domestic sludge, 5 persons/m² for raw mixed sludge and 6 persons/m² for digested mixed sludge; however this was found to be insufficient, and later work^{28,29} showed that an area representing 2-3 persons/m² was necessary for digested sludge. Another method of calculating the area required is to multiply the estimated annual number of applications to the drying beds by the optimum loading, expressed as kgDS/m². Then the annual dry solids production is divided by the loading per annum, per square metre. Allowance should be made for any reduction of solid matter where sludge digestion is used.

2.2.4.2 Inlets. Sludge is applied to a drying bed at one or more points from a channel with hand stops, or a pipeline with valves. The discharge point is above maximum sludge level and erosion of the surface media is prevented by providing a concrete slab onto which the sludge can fall. Inlets in the form of spaced aluminium alloy weirs or siphonic outlets on the lifting machine are commonly used to minimize erosion of the surface.

2.2.4.3 Media. In the early days the medium was ungraded but it was soon realized that, to prevent solids escaping to the under-drains, there had to be an upper layer of fine material such as sand or ash, supported by one or more layers of material of greater size, all being supported by the drainage tiles (Fig. 11).

Since the medium tends to compact and lose its porosity, attempts have been made to provide a drying bed surface of a more permanent porous

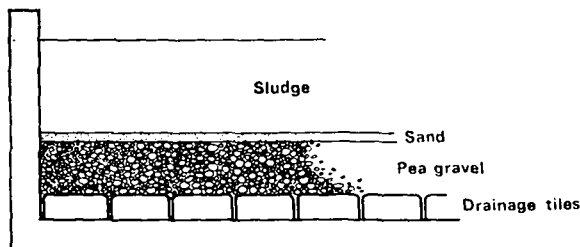

Fig. 11. General arrangement of sludge drying bed.

nature. Concrete has been tried at Bournemouth³⁰, porous concrete at several works^{31,32} and experiments have been carried out using wedgewire³³ as the drainage medium.

The purpose of the upper layer of fine material is to act as a support for the first sludge to be deposited which then itself becomes the filtration medium, allowing liquor to pass through. The lower layers of medium are so graded that they permit liquor passing through the fine upper layer to percolate freely through them, and are of such a thickness as to protect the underdrains from damage. Compaction of the medium and damage to the underdrains are most likely to be caused by wheeled vehicles turning on a bed or tracked machines slewing. This should be avoided and concrete strips should be provided for the vehicle to manoeuvre. Where wheelbarrows are used, planks are often used to prevent unnecessary trampling on the surface. This does not occur in beds operated with a mechanical sludge lifter, but the upper layer of ash or sand is picked up with the sludge and must be replenished periodically.

The fine upper layer is usually sand, fine ash or pea shingle. The supporting material must be durable, e.g., gravel, clinker, broken stone or perforated clayware tiles.

2.2.4.4 Underdrains. Underdrains must be provided for the discharge of liquor from the drying bed and the system is often arranged in a herring-bone pattern or alternatively as a false floor of perforated tiles.

2.2.4.5 Floor. Where the subsoil is impervious, an earth floor may be used but this should preferably be sealed with bitumen. Otherwise, the floor should be made of concrete, the thickness depending largely on the method of removing the dried sludge, with a slope of not less than 1 in 60 towards the main drain or outlet chamber.

2.2.4.6 Walls. Walls should not extend to such a height above sludge level that they reduce the evaporation effect of wind and shield the sun, thus retarding drying and delaying removal of the dried sludge.

2.2.4.7 Covers. The dewatering of sludge in open beds is greatly affected by the weather and the lifting of dried sludge is usually confined to the summer months. To overcome this, covered beds were tried at Kew³⁴ and Reigate³⁵, but they were found to have little beneficial effect.

2.2.4.8 Provision for removal of dried sludge. Removal of dried sludge involves lifting, followed by conveyance to a storage area or loading into a skip or vehicle. Lifting usually starts in March and may continue into the following winter.

On small works, the sludge is lifted into a wheelbarrow, using a fork or shovel, and conveyed to an adjoining tip. On larger works, light railway tracks are often used, the sludge being lifted and loaded by hand into side-tipping wagons which are pushed by hand or drawn by an engine to the storage area. A gap is left in the wall of the bed for portable track to be laid, the gap being sealed with planks fitting into slots when the bed is to be refilled.

Sometimes the beds are long and narrow with a road running alongside so that sludge can be loaded onto a vehicle; or the bed has a ramp at each end so that vehicles can enter and leave without turning, two concrete strips being provided for the wheels to run on. Another arrangement is for the vehicle to enter the bed and be loaded direct using an elevating conveyor, or a mechanical shovel. Most drying beds which have been built recently are equipped with mechanical lifting machines which can re-sand, level, cut and lift the sludge from the surface.

2.2.4.9 Withdrawal of separated liquor. When liquid sludge is applied to a drying bed, a proportion of the liquor is removed by drainage, but later it is possible to remove surface water by decantation. Drying beds may be provided with weir penstocks or wooden slats 25–55 mm wide, fitted into slots, which can be removed one at a time or parted to permit liquor to escape between them. Alternatively, at small works, telescopic valves or removable pipe collars may be used.

2.2.5 Operation

2.2.5.1 Preparation of bed surface. Before fresh sludge is applied, the bed surface must be raked to remove particles of sludge or mixtures of sludge and fine medium. This is especially important before a bed is re-sanded. When compaction of the medium has taken place it is sometimes necessary to fork over the bed. The bed surface must be level, otherwise the thickness of the sludge will vary and, since the thicker portions will take longer to dry, lifting will be delayed.

2.2.5.2 Application of sludge. A bed should be filled in a single operation and the sludge lifted before any further application. A second application or

“topping-up” disproportionately extends the drying period beyond that required for two successive applications to the same drying bed.

2.2.5.3 Lifting dried sludge. With mechanical lifting equipment (Plate 3), coulters are often provided to cut drainage lines through the drying sludge to encourage draining. Sludge may be lifted as soon as it has cracked and formed discrete lumps, its solids content then varying from 20% to 30% depending upon the drainability of the sludge. The extent to which sludge is dewatered before lifting depends on the type of equipment used for lifting and handling the dried material and on the method of disposal.

2.2.5.4 Odour problems. Nuisance may be caused by the offensive odour from raw sludge being dewatered on drying beds. They should be situated as far as possible from houses. Where smell is causing a nuisance, masking agents sprayed into the atmosphere have often been used.

2.2.6 Maintenance

2.2.6.1 Replenishment of top dressing. Since the fine upper layer of medium adheres to the dried sludge when it is lifted, it must be replenished at intervals. The number of fillings before this becomes necessary varies widely, with some manually-cleaned beds needing replenishment almost every time they are used whilst, with mechanically lifted beds, there may be 15 fillings before re-sanding. Before replenishment, the surface must be levelled.

2.2.6.2 Lifting machines (Plate 3). These incorporate motors, gears, conveyors and chains which present no special problems, and the manufacturers' maintenance schedules should be followed.

2.2.7 Performance

2.2.7.1 Factors affecting performance. Factors affecting the performance of drying beds include:

- (a) the nature of the sludge;
- (b) its initial dry solids content;
- (c) the depth of application;
- (d) the condition of the drainage medium; and
- (e) the weather conditions.

(a) *Nature of sludge.* Raw sludges, and especially those containing a high amount of grease, tend to dry only slowly by evaporation above a dry solids content of about 30%, but digested sludges normally crack more

readily forming a highly fragmented cake which, in suitable weather, will dry to a DS content as high as 70%. A sludge which drains readily leaves a cake of relatively uniform dry solids content but one which drains slowly leaves a cake which is wet and sticky in the lower layers and a hardened surface crust.

- (b) *Initial dry solids content of sludge.* It is preferable to consolidate or thicken the sludge as much as possible before application in order to reduce the proportion of liquor which has to be removed by drainage; but the DS content must not be so high that the sludge will not flow to all parts of the bed or be of an uneven thickness when dry.
- (c) *Depth of application.* The depth to which sludge is applied varies between 150 mm and 350 mm. With mechanically-lifted beds the depth of application is often 200 mm. If the application is too shallow, the thickness of the sludge layer when dry will be small and more applications will be required to deal with a given volume of sludge. The number of applications normally varies from 3 to 5 per annum but more can be achieved using thinner applications on mechanically-lifted beds.
- (d) *Condition of drainage medium.* Drainage of liquor from the sludge is affected by the condition and grading of the medium and the effectiveness of the drainage system. If drainage is hindered, a greater proportion of the liquor has to be removed by decantation and evaporation.
- (e) *Weather conditions.* Rainfall has a considerable effect on dewatering, especially before cracking. Evaporation is reduced in cloudy or humid conditions but wind has a beneficial effect. If sludge on a drying bed freezes, it drains readily after thawing. Alternatively frozen sludge may be removed manually when it still has a low solids content. Drying conditions are good during only 6–7 months of the year and, therefore, most sludge produced in the full year has to be dried within this period.

2.2.7.2 Loading. The loading of a drying bed is assessed in terms of the weight of DS applied per unit area per annum. When dewatering digested sludge to 40% DS content, the Water Pollution Research Laboratory^{28,29} found that the optimum load per application was about 11 kg dry solids/m².

2.2.7.3 Separated liquor. The liquor from a sludge-drying bed consists partly of drainage and partly of supernatant water, and is usually returned to the sewage works' inlet for full treatment.

2.3 Filter Press

2.3.1 Introduction

Filter presses were in use prior to 1880 and, following development¹⁶, their popularity increased with the use of chemical precipitation for the treatment of sewage. However, with the development of the biological filter, and more particularly the activated-sludge process, problems were encountered with the filter pressing of biological sludges. By the mid-1930s, filter pressing was mainly confined to the Yorkshire woollen towns (e.g. Bradford, Halifax, Huddersfield and Morley), where grease was extracted for sale.

During the late-1950s, however, there was renewed interest in filter pressing as a result of design improvements, and the development of new chemical conditioners.

2.3.2. Design

2.3.2.1 Types of filter press. A filter press consists of a series of chambers formed between recessed plates; in some cases flush plates with distance pieces between them are used. An appropriate filter cloth is fitted over the surfaces of each plate. The plates are closed together and held by sufficient force, applied either hydraulically or by screws, to withstand the applied filtration pressure. The seal between plates is obtained by the pressure on the filter cloth between the rims (gaskets) of adjacent plates.

Sludge, after conditioning to improve its filtrability, is pumped into chambers through feed holes in the plates. As a result of the pressure which develops within the chambers, filtration of the sludge occurs, the filtrate passing through the filter cloths and out of the press via ports, the sludge solids being retained within the chambers as a cake. Pumping of sludge into the chambers continues until they become filled with cake and the flow of filtrate virtually ceases. The pressing is then complete, pumping is stopped and the press is opened to release the sludge cake from each chamber. After the cake has been removed, the press can be closed and another cycle of operation commenced. Presses are usually fitted with canopies and/or curtains to prevent sludge which may occasionally blow out from between the plates from fouling the walls and ceiling.

Plates can be suspended either by a side-bar or from an overhead beam.

- (i) *Side-bar press* (Plate 4). The compressive force which is required to hold the press plates together is transmitted between the two end plates by

side-bars in tension. These bars also serve to support the intermediate press plates which have lugs resting on the side-bars. Since the movement of each plate necessitates overcoming sliding friction between the lugs and side-bars, manual operation is usually confined to small installations, and mechanized gear for opening the individual chambers is normally incorporated. The press is closed and locked by a follower plate driven from one fixed end of the press.

- (ii) *Overhead-beam press* (Plate 5). In an overhead-beam press, the intermediate press plates hang from an overhead beam by means of rollers with tracking assemblies to ensure alignment. Side bars are still required to carry the press closing forces, but are not used to support the plates. In this type of press large plates may be manipulated manually.

There is a type of overhead-beam press where closure of the press, which is usually by means of one or more hydraulic rams, is possible from either end of the press. In this case, the final connexion of the sludge feed pipe-work to the press is via a length of flexible hose.

2.3.2.2 Buildings. It is essential for presses to be installed at first-floor level so that cake discharge from them can fall into a suitable collection system at ground level.

It is important that detailed consideration is given to the arrangement and weight of the plant and equipment and the sizing of the buildings housing pressing installations. Adequate space should be allowed around each unit to facilitate operation, cleaning, maintenance, as well as to minimize potential hazards. Forced ventilation is desirable.

2.3.2.3 Sludge storage and conditioning tanks. In order to achieve consistency of the sludge to be processed during each pressing cycle, sludge storage tanks are required with some method of agitation and sufficient capacity for at least a full pressing cycle. If the tanks are to be used to store sludge, agitation must not be violent, otherwise floc breakdown and deterioration of the filtrability of the conditioned sludge will occur.

2.3.2.4 Press feed pumps and ancillary equipment. Positive-displacement pumps are required to achieve the high pressures which are required in filter pressing; they also have less shearing effect than rotodynamic pumps on the conditioned sludge flocs. The Willett ram pump, which is an hydraulically-operated variable-flow pump designed to operate at pressures up to 2000 kPa, was introduced in 1950, and this type of pump has been used on many

of the more modern pressing installations. Variable-flow pumps, automatically controlled according to the pressure in the system, obviate the need for pressure buffer vessels.

At the Coleshill plant³⁶ the press feed system provides for low and high pressures. To charge the presses during the initial stages Mono pumps are used; at 320 kPa, hydraulically-operated ram pumps, which automatically adjust to pressure, come into operation up to a maximum pressure of 690 kPa.

At Sheffield³⁷, diaphragm-type pumps operate on low pressure/high speed to a pressure of about 550 kPa and change to a high pressure/low speed, up to a maximum pressure of 690 kPa, the changeover being controlled by pressure switches.

High-pressure jetting pumps for cloth washing and/or plate cleaning are required; cloth-washing machines may also be used.

Filtrate should not drain into the cake collection area. Suitable pumps must be provided for delivery of the collected filtrate to the works' inlet, and the pumps must be capable of dealing with the maximum flow of filtrate produced during the initial stages of the filtrate cycle.

2.3.2.5 Plates and drainage. Plates are square or rectangular and drainage surfaces may be in the form of truncated pyramids or cones, flat cylinders, domes or diamonds. Cast-iron plates have normally been used, but on more recent installations considerable use has been made of steel-insert rubber-moulded plates. These have the advantages of less weight, increased strength and chemical resistance, greater ease of cleaning and manual operation, and less physical damage to filter cloths, as compared to the cast-iron plate.

Bosses, which virtually touch on adjacent plates when the press is closed up, are cast as part of the centre web of the plate to counteract out-of-balance pressure between chambers; these reduce the amount of flexing which would otherwise occur and possibly result in plate breakage.

The sludge feed hole is normally at (or above) the centre of the plate. Some plates are available with more than one feed hole; this gives a better distribution of solids over the complete filtration area and reduces the occurrence of uneven pressure conditions within the press. If the feed holes become blocked (i.e. 'coring' takes place), a distorting pressure is created and plates may develop hair-line cracks and eventually break. An early symptom of this 'coring' is the production of cakes of varying concentrations of dry solids or half-empty chambers.

Recently there has been an increased interest in the membrane filter plate (Figs. 12(a) and 12(b)). The chamber size is varied by a flexible rubber membrane on either or both sides of the chamber. Normal filtration is first carried out and, later in the cycle, the cake is compressed by the application of pressure from behind the membrane. The use of membrane plates³⁸ can reduce the pressing cycle period and provides for production of cakes of various thickness. Membrane plates are normally operated so that, when about 80% of the filtrate has been removed (usually about half the pressing cycle period), sludge feeding is stopped and the membrane is inflated from behind using compressed air. This compresses the cake and rapidly squeezes out additional filtrate. It has been reported that this compression also assists with cake release from the cloth³⁸.

The filtrate may be collected in open or enclosed systems; if open, the filtrate discharges from peripheral ports, and is collected either in trays

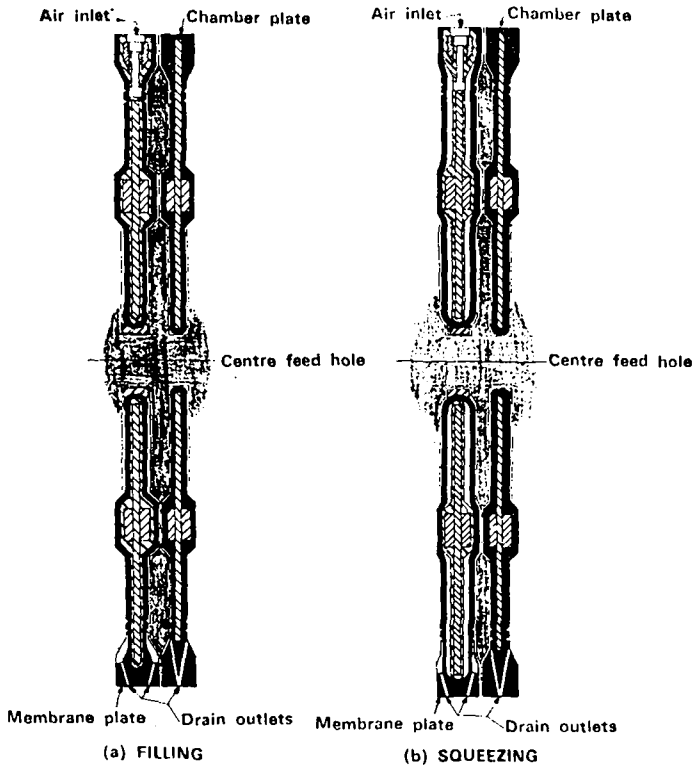

Fig. 12. Cross-sectional view of membrane plate.

below the press or in channels alongside. In the enclosed system drainage is discharged through ports contained within the press plates or through a collection manifold. Drainage collection trays below the press are either telescoped to one end of the press, or hinged along the sides so that they can be opened downwards to allow cake discharge.

2.3.2.6 Mechanization. Systems for the mechanical movement of plates, automatic closing and opening of presses have been developed. However, a complete system for automatic operation and discharge of cake for the filter pressing of sewage sludges is not yet available because of the high capital cost which would not be offset by savings in labour costs.

Several methods of mechanized-plate movement are available for both side-bar and overhead-beam presses. On the side-bar type of press there is usually a mechanism on each side of the press which consists of triggers (pawls) attached to an endless chain, or attached to reciprocating slide-bars. The triggers engage with horizontal pins attached to the plate handles. The mechanisms are driven by conventional motors and gearboxes, sometimes incorporating a slipping clutch device. A traversing pneumatically-operated design of plate movement gear is also available for side-bar presses.

On overhead-beam presses the mechanism travels parallel and close to the support beam and uses endless chains or ropes which have triggers or an escapement mechanism attached (normally a single mechanism suffices for this type of plate), the mechanism being driven by motors and gearboxes or initiated by compressed air.

Safety devices to prevent an operator's hand being trapped between plates are incorporated on mechanized presses. Earlier installations utilized photo-cell units but, more recently, infra-red light systems have been introduced, to stop operation automatically when the beam is interrupted.

2.3.2.7 Filter cloths. The efficiency of filter pressing is dependent upon selection of a suitable filter cloth. This acts as a filtering medium during the initial stage of the formation of the cake layer; subsequently the cake becomes its own filter medium, the cloth just acting to contain the cake.

Filter cloths should comply with the following requirements:

- (a) the fabric must be capable of retaining the particles present in the feed sludge without the cloth becoming 'blinded', and must allow a clean discharge of cake;

- (b) the physical properties of the fabric should minimize wear, shrinkage and creasing;
- (c) they must have adequate porosity to permit the maximum rate of filtration; and
- (d) the fabric must resist chemical and fungal attack.

Liquor drains through the cloth in two directions. Where the cloth bridges the drainage channels on the press plate the flow is directly through the cloth. In areas where the cloth touches the projections on the plate surface, the filtrate flows laterally through the cloth in order to get to the drainage channels. The amount of lateral flow occurring in practice depends on the surface design of the plate.

- (i) *Cloth design.* Cloths are manufactured as single (throw-over) cloths or double (barrel-neck) cloths. The former, which can be used only on side-bar presses, fit over the top edge of a press plate and hang down both sides, with suitably aligned holes for the sludge feed ports. They are held in position at the feed hole in the plate by a union screwed from each side of the plate with flanges fitting over the cloth.

Barrel-neck cloths consist of two single cloths joined by a cylinder of the cloth material, which fits inside the sludge feed hole of the plate. Such a cloth is fitted to the plate by pushing one side through the feed hole and securing the cloths on each side of the plate by fixing with a rod and clips along the top edge of the plate.

Correct fitting of the cloths is important so that tearing, creasing and excessive wear are avoided. Often eyelets are provided in cloths down the vertical edges on each side of the plate in order to fit ties, which assist in keeping the cloth in position. Alternatively they may be stapled down the edges. In sizing cloths, adequate allowance should be made for shrinkage, depending on the type of material used.

- (ii) *Cloth materials.* Until about 1950, prior to large-scale production of synthetic fibres, natural fibres which were used included cotton, wool, jute and flax. Cotton was used in alkaline conditions but the cloth blinded easily, and wool was used in acidic conditions. Both have poor resistance to microbial attack.

Materials in present use include polyesters (terylene), polypropylene (PP), polyvinylidene (PVD), polyvinyl chloride (PVC), polyethylene and polyamides (nylon). The majority of these are woven in the form of a mono-filament, multi-filament, continuous filament or staple fibres.



Plate 1. Apparatus to determine capillary suction time

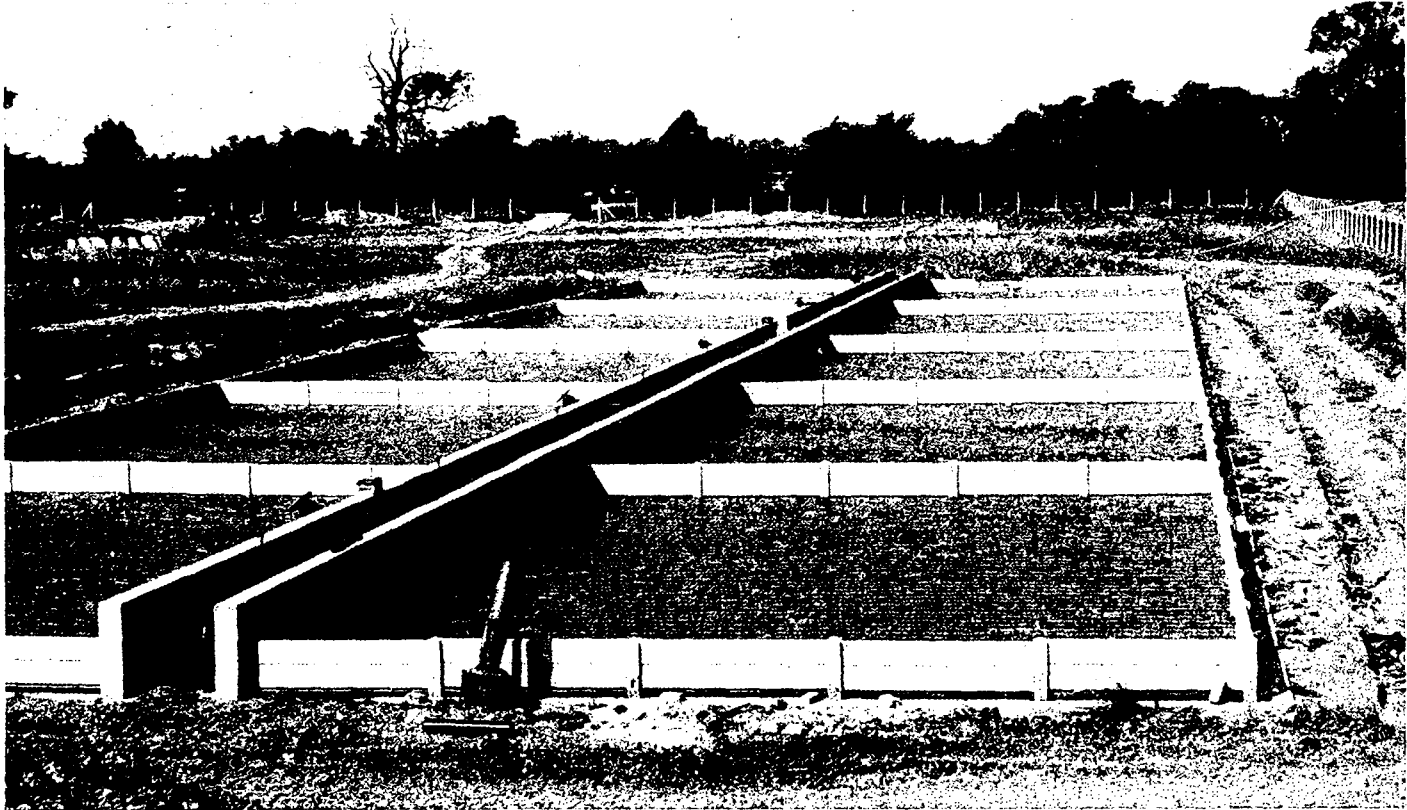

Plate 2. General view of sludge drying beds

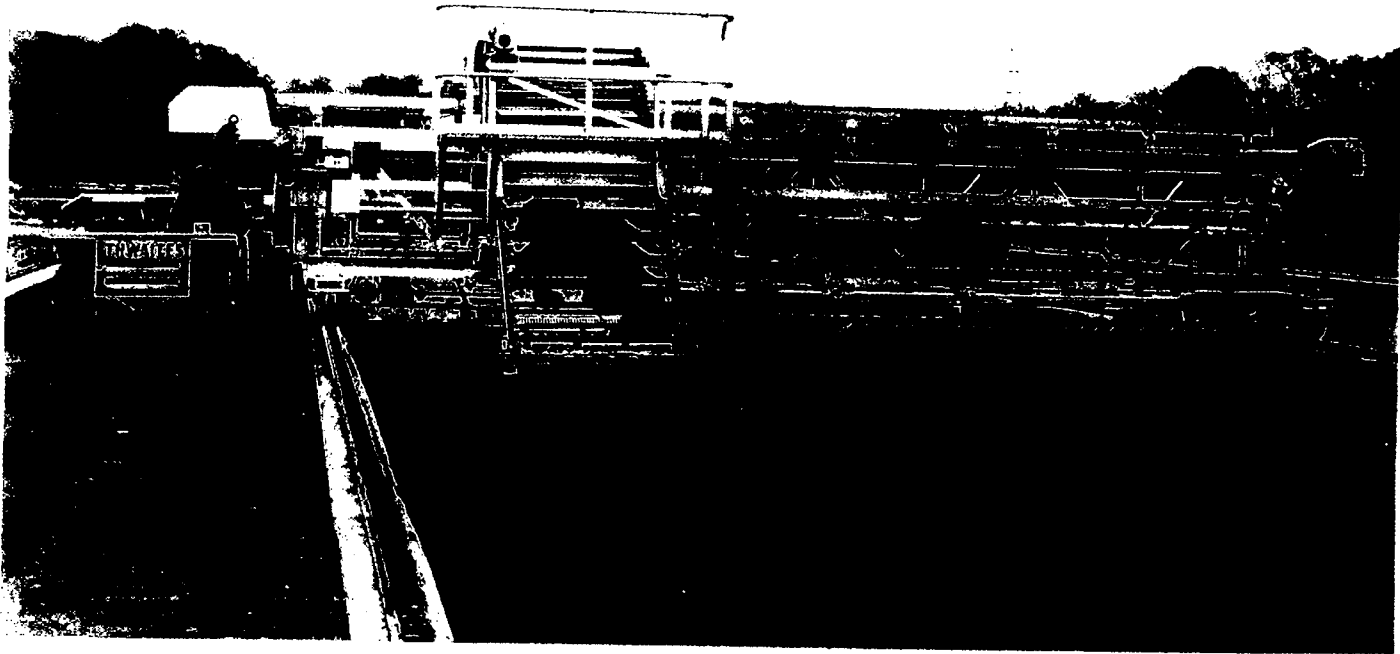

Plate 3. Mechanical lifting equipment on sludge drying beds (at Galashiels)

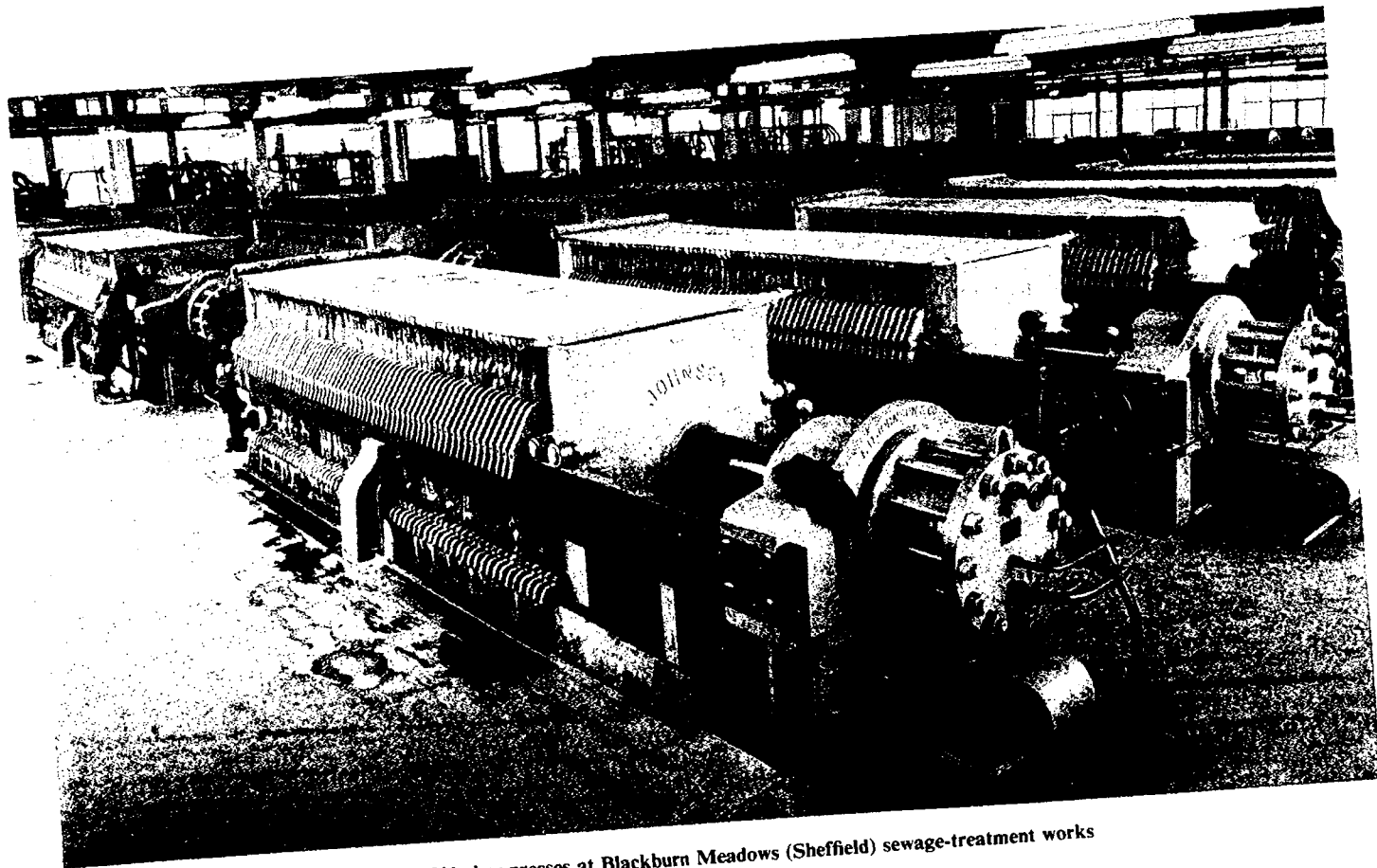

Plate 4. Side-bar presses at Blackburn Meadows (Sheffield) sewage-treatment works

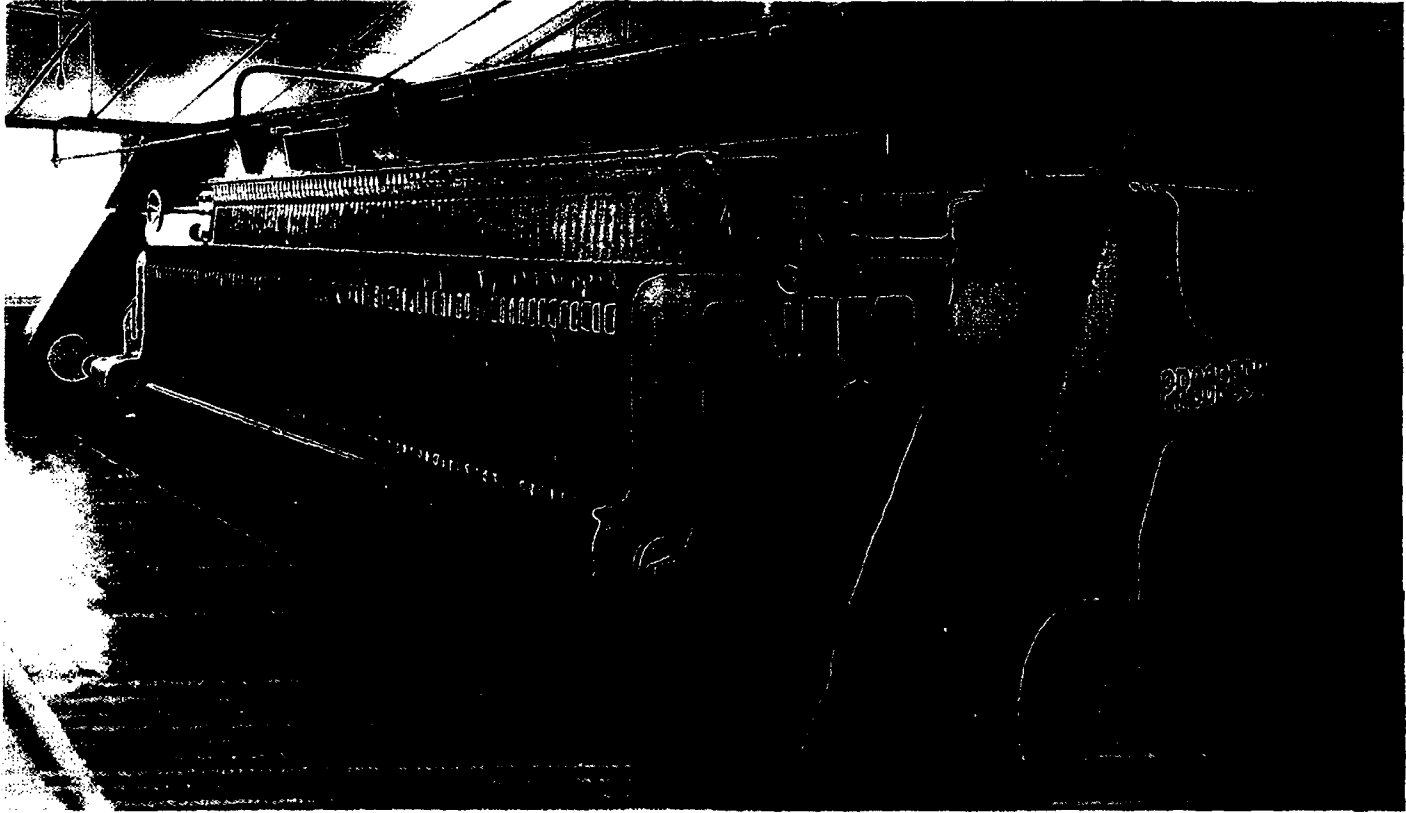

Plate 5. Overhead-beam press at Walsall sewage-treatment works

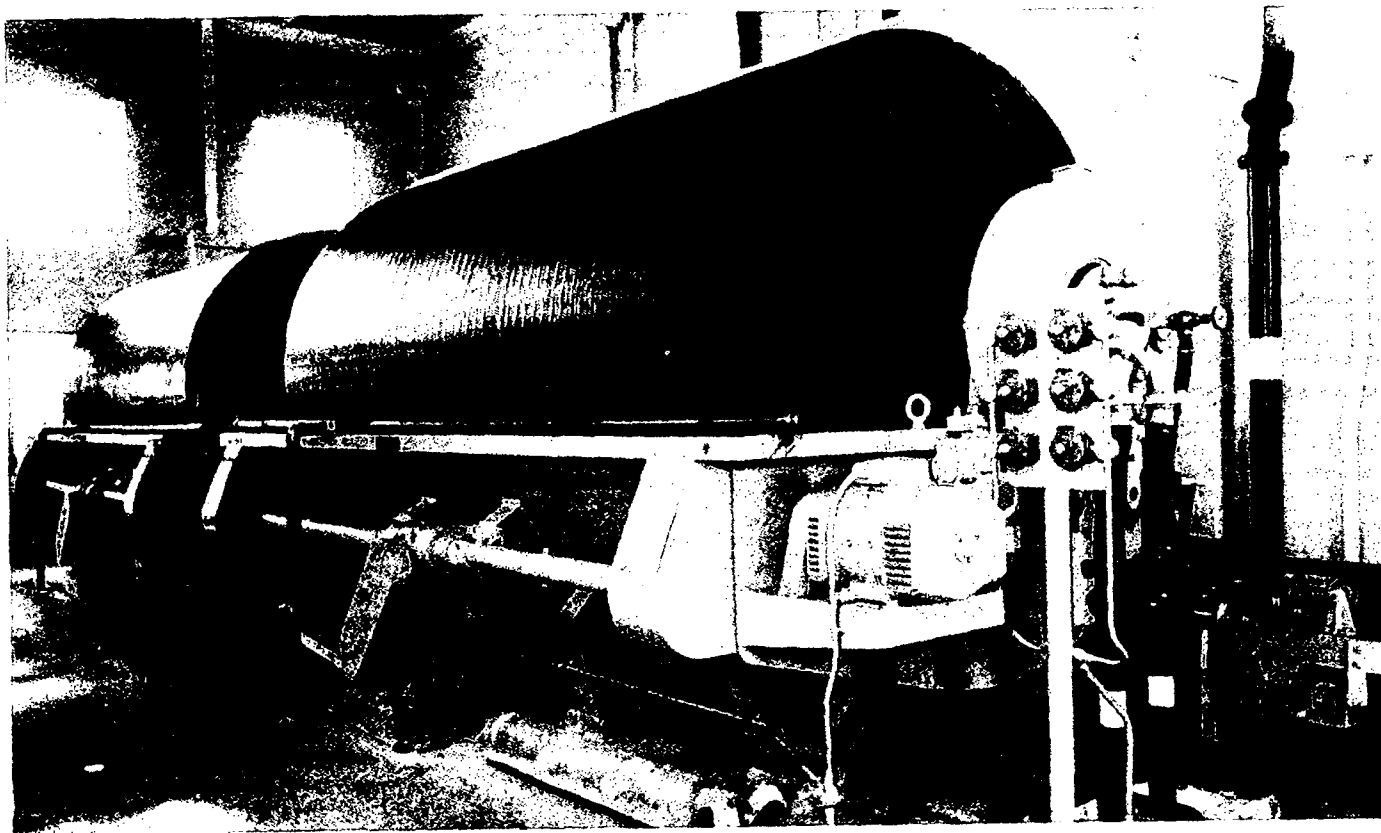

Plate 6. Vacuum filters at Parr (St. Helens) sewage-treatment works



Plate 7. View of a coil filter installation

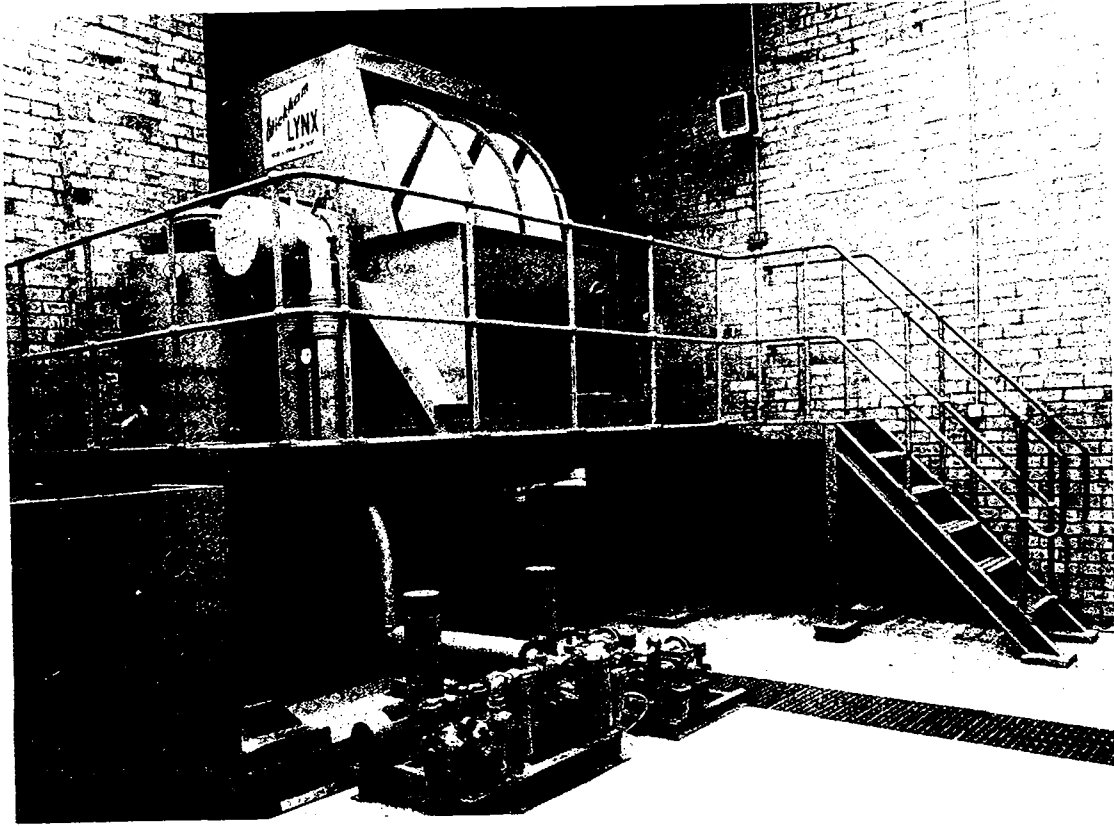

Plate 8. General view of a vacuum disk filter installation

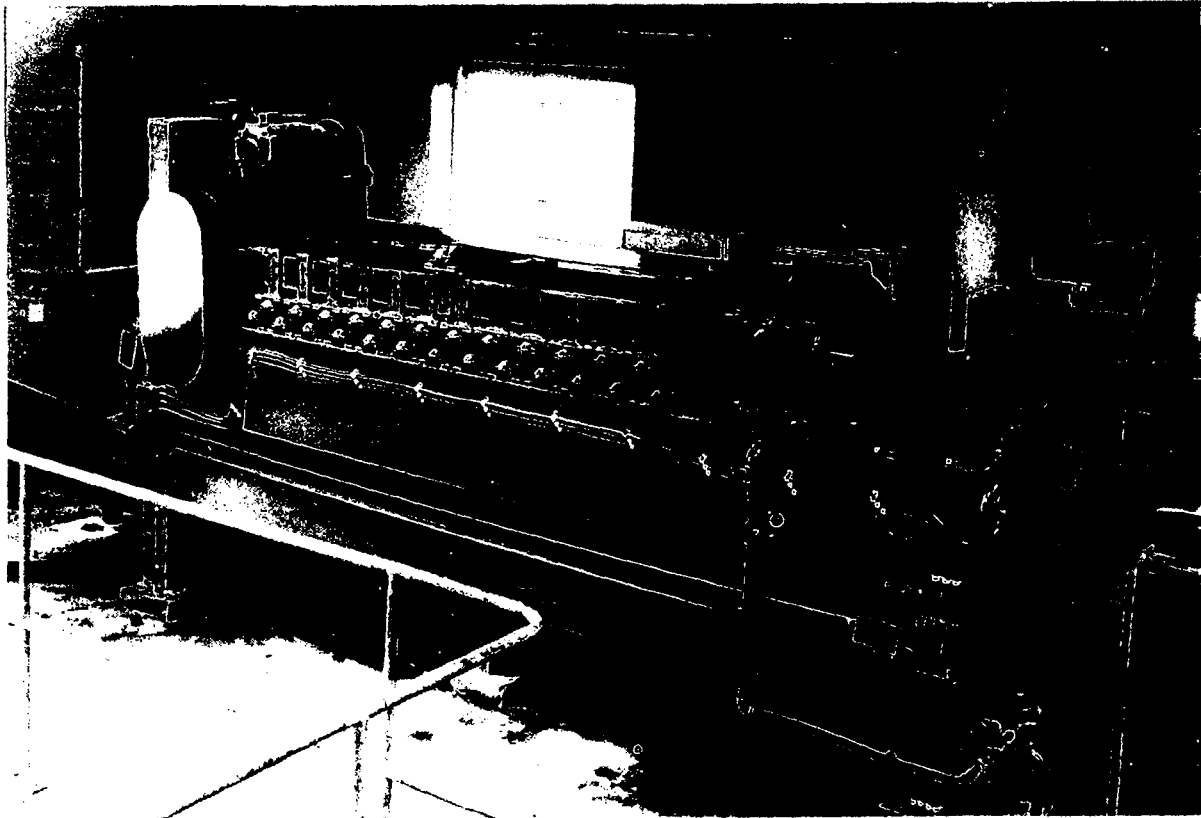

Plate 9. General view of a filter-belt press installation

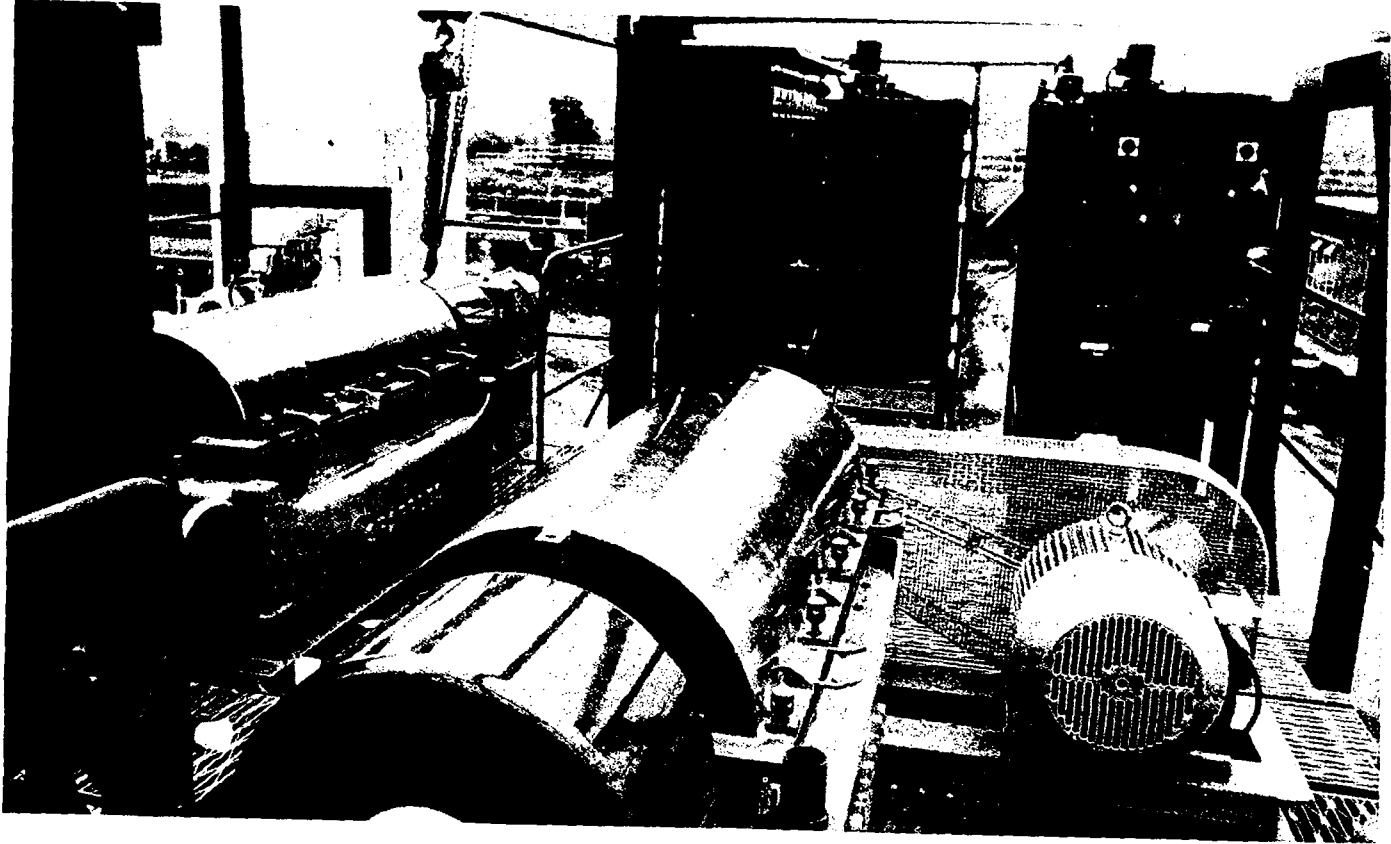

Plate 10. General view of a solid bowl scroll discharge centrifuging plant

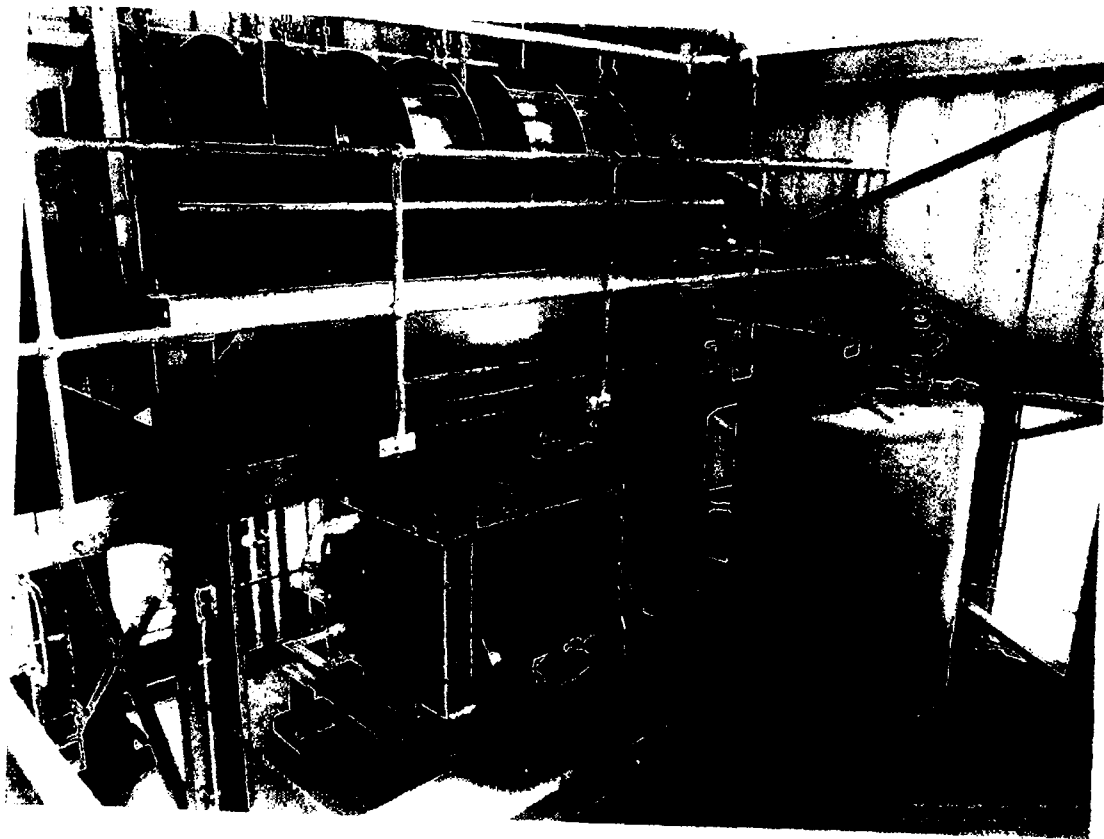

Plate 11. General view of a Rotoplug concentrator installation

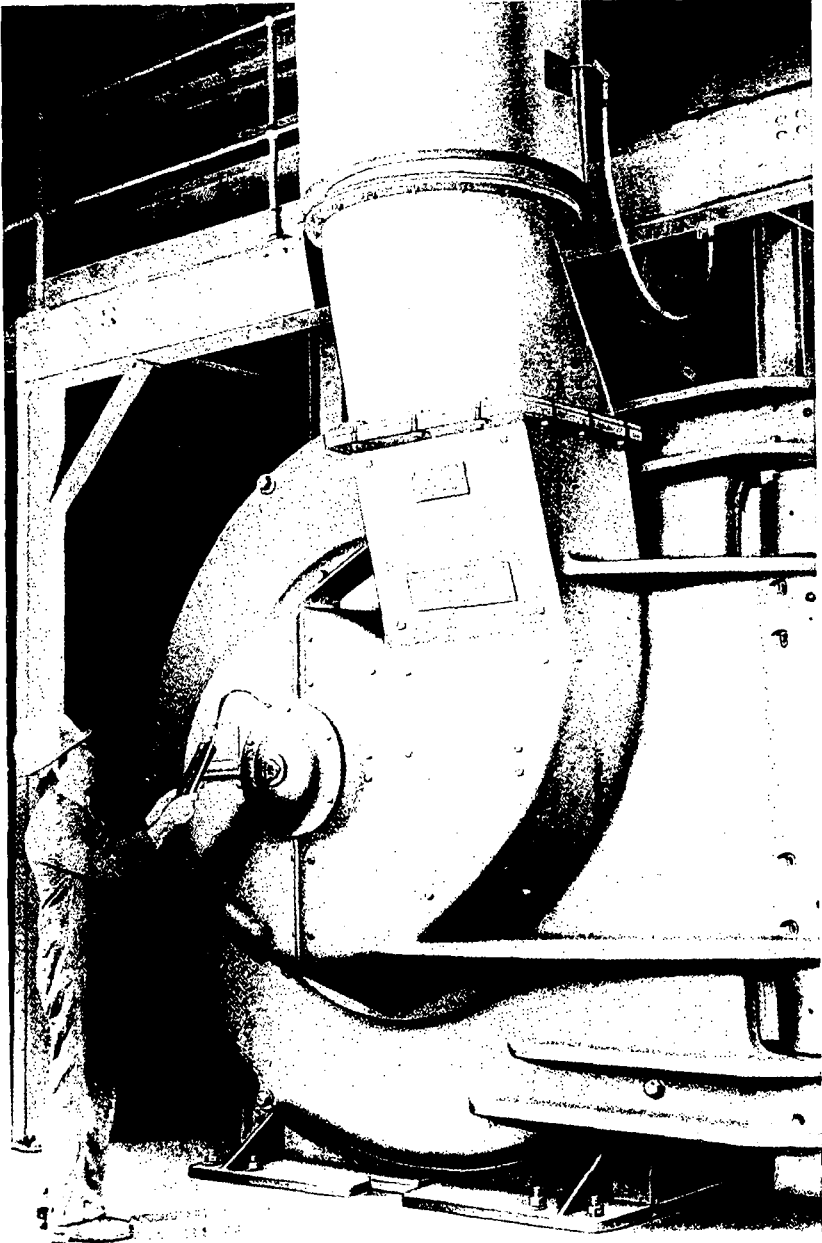

Plate 12. General view of atritor drier

- (iii) *Fibres*. Synthetic fibres are normally manufactured in three forms:
- (a) *Continuous multi-filament*: Several fibres of unlimited length are twisted together tightly to produce a smooth yarn, which may be woven into a fabric.
 - (b) *Mono-filament*: Consists of unlimited lengths of extruded fibre usually of coarse diameter (1.5 mm) woven into fabric. Such cloths are very smooth, strong and have a high mechanical resistance. They cannot be made into a close-woven fabric and therefore may not retain fine solids particles.
 - (c) *Staple fibre*: An extruded continuous fibre is cut into short lengths, which must be carded and spun into a yarn prior to fabric weaving. Despite having lower tensile strength than continuous filaments they are very resistant to mechanical damage and abrasion.
- (iv) *Weave properties*. Three types of weave are normally used in cloth manufacture: plain, twill and broken twill.
- (a) *Plain*: The weft thread is passed over and under successive warp threads, which give a fairly rigid cloth of small bulk. The surface is even and smooth which encourages good cake release. Solid particles can readily enter the weave spaces, leading to blocking.
 - (b) *Twill*: The most frequently used weave is that in which the weft thread passes over and under two warp threads and is termed a 2/2 twill. The next weft thread uses a different two-warp thread which gives a surface weave diagonally channelled. Such cloths are very flexible, have a high bulk weight to volume ratio and good resilience and mechanical strength. It is more difficult for particles of solids to enter the weave spaces as these are partially hidden and hence less prone to blockages. Cake release is not as good compared with plain weave.
 - (c) *Broken twill*: Such cloths usually have quite smooth surfaces, giving good cake release, and are flexible. They are more susceptible to blinding than twill weave, but less susceptible than plain weave. More recently needle fabrics have been introduced, which comprise an interlocked mass of synthetic fibres with no interweave spaces, giving the appearance of a woollen felt. They usually allow high flow rates and have good solids particles retention, but cake release properties are usually inferior.

- (v) *Choice of cloth.* The best assessment of cloths is carried out on the operational installation. However, this is not always possible and alternative methods of testing are available. A laboratory-scale filter press can be used in which different cloths can be fitted to a number of plates and assessed under the same conditions during a number of pressing cycles, but this will not usually indicate the life expectancy of cloths. Liquid permeability tests can be carried out and a useful test is described by White and Baskerville³⁹. Whatever tests are carried out, ultimately the choice of cloth must depend on an acceptable filtration performance in full-scale plant operation. The resistance to filtration of the filter cloth is generally considered to be relatively small when compared with the resistance of the cake formed. However, if the cloth becomes blinded, performance will be affected considerably. The spaces in the weave should be a maximum when considered in relation to the size of the sludge particles to be retained.

An open-weave, mono-filament cloth has low resistance to lateral flow and is therefore of particular advantage where plates are dirty and/or the cloth is touching a relatively high proportion of plate drainage surface. Tight-weave multi-filament cloths are more suitable for activated and digested sludge (fine solids).

2.3.2.8 Cake handling and disposal. Satisfactory provision must be made for the collection and disposal of press cake; this may include storage hoppers and conveyors. Tension wires or bars are sometimes incorporated beneath the press in order to break up the cake, and mechanical breakers can be installed for reducing cake size. The cake is usually collected in a suitable truck or hopper positioned beneath the press.

2.3.3 Application

Filter pressing produces a drier cake than that from other mechanical dewatering devices; therefore the volume of sludge cake is smaller and handling costs are minimized. The filtrate normally contains a relatively small concentration of SS, although this can vary with the type of sludge, conditioner and cloth.

The process is usually applied to raw sludges, but has been used to a limited extent for digested sludges^{40,41} and heat-treated sludges. Pressing trials on different types of sludge have been reported by Brade and Sambidge⁴², who found that for raw mixed sludge containing 50% activated sludge the chemical requirements were high and cake quality was variable, with wetter centres and a degree of filter cloth binding. Improved results were

obtained on such sludge using 'in-line' conditioning. Pressure filtration of this sludge following digestion was unacceptable, but excellent results were obtained following elutriation of the digested sludge 3:1 with final effluent, obtaining cakes of about 40% DS using either aluminium chlorohydrate or lime/copperas as conditioning agents and a 4–6 h pressing period.

2.3.4 Operation

The operational cycle of a filter press consists of three main phases:

- (a) Filling and pressure build-up (0.2–1.5 h);
- (b) Filtration under maximum pressure (2–12 h);
- (c) Cake discharge (0.1–0.5 h).

The duration of phases (a) and (b) depends upon the feed pump rate and pressure, type of sludge, DS content and filtrability, the type and condition of the filter cloths, and the design and cleanliness of the press plates. The duration of phase (c) depends on the number of plates, the cake quality type, and condition of the filter cloths, and the design and method of movement of plates. Phase (b) is usually the one that takes the longest period and in a pressing cycle of, say, 6 h duration, could occupy 80% of the total cycle period. Hence attention to the factors influencing stage (b) offers most benefit in reducing the pressing cycle period and improving overall efficiency. Advantages are claimed for the membrane-type plate in the reduction of duration of this phase by the application of a 'squeeze' pressure.

2.3.4.1 Sludge conditioning and mixing (see also Section 1.4). Various chemicals are used of which lime and iron salts, aluminium chlorohydrate and organic polymers are the most common. Webb⁴³ has described extensively work in connexion with the conditioning of sludge with lime. Conditioning equipment consisting of a series of baffled compartments with stirrers has been described by Ashman and Roberts⁴⁴, and similar equipment has been utilized in investigational work at the Water Research Centre^{45,46}.

The Coleshill pressing plant³⁶ incorporates chemical addition and mixing in open channels down which the sludge flows, mixing occurring as a result of turbulence.

Recently, several filter press plants have been modified for the use of poly-electrolytes which are added 'in line'. The system, which is used in conjunction with a piston-type sludge pump, allows for a controlled dose of polyelectrolyte to be added to the feed sludge before pumping, thus utilizing the pump as a mixing chamber.

In operation, polyelectrolyte is pumped continuously and, when the sludge pump is making its suction stroke, it is diverted into the sludge line via a solenoid valve. At the end of the suction stroke, this valve is closed and the polyelectrolyte is then diverted back to the storage tank. Thus the sludge pump acts as a control mechanism for the dosing of the polyelectrolyte.

2.3.4.2 Rate of feed and pressure. The rate of feed to the press and the rate of pressure increase in the press can have considerable effect on the cake structure and consequently on the efficiency of the process. Too rapid an application of pressure may affect the uniformity and compaction of the cake (and hence its quality), increase cloth blinding and cake adhesion to the cloths, and produce a filtrate of inferior quality.

Ideally, sludge should be fed to a press in such a manner as to give a relatively steady build-up of pressure, and it is preferable to utilize a variable-speed pump. It has been considered to be an advantage to install separate pumps to each press and provide interconnecting pipework such that several pumps may be operated to feed each press to a predetermined pressure, followed by completion of the pressing cycle using a single pump to each press.

Work at the WPRL^{47,48} demonstrated that, with pressures up to 2000 kPa, the solids content of the cake increased substantially as the pressure increased, but above this value there was only a gradual increase up to about 60% DS, which was the maximum that could be achieved using pressure filtration. Hence the main effect of increase in pressure is an improvement in the concentration of dry solids. It is usual to apply a maximum pressure of about 690 kPa in the pressure filtration of sewage sludges, although an increased pressure may be applied for part of the cycle by use of membrane-type plates³⁸ in which the volume of the chamber is varied.

2.3.4.3 Pressing period. In practice it is usual to continue the pressing period until the rate of filtrate discharge has reduced to the point where continuation of the pressure application achieves little further practical benefit.

Edmondson and Lumb⁴⁹ carried out pilot-scale experimental work concerning cake thickness during the pressure filtration of various types of sewage sludge, and found that the pressing period required was approximately proportional to the square of the cake thickness.

During 1970, the WPRL using a filter press with 400-mm square plates and PVC monofilament filter cloths, investigated the effect of the period

during which maximum pressure was attained^{47,48}. Using sludge of constant specific resistance, tests showed that the pressing period decreased as the feed sludge dry solids concentration increased, the pressing period reducing from 18.0 h to 5.7 h with an increase in feed sludge dry solids content from 3% to 6% DS.

2.3.4.4 Maintenance of plates and cloths. During investigations into the effect on performance of clean cloths and drainage surfaces^{45,50}, it was reported that with a dirty cloth the resistance to filtration increased by 100 times, but was negligible compared with the resistance of the cake. However, with blocked drainage channels on the plate the filtrate had to flow laterally through the cloth instead of through the channels, and this amplified the effect of a dirty cloth.

Factors affecting cloth blinding are:

- (a) The quantity of fine solids particles in the sludge and the capability of the chemical conditioner to coagulate them;
- (b) The efficiency of the drainage surface on the plate;
- (c) The aperture size, type of filament and weave of cloth;
- (d) The effect of the feed system to the press on the conditioned sludge flocs.

Press cloths will ultimately become partially blinded and it is prudent to have a planned schedule of cloth washing and repair, and plate cleaning. Cloths may either be washed *in situ* by high-pressure jetting, which also serves the purpose of cleaning the press plates; alternatively the cloths should be removed and laundered in industrial washing machines. All filter cloths should be changed simultaneously so that the cake quality within a particular press is constant from chamber to chamber. The frequency of cloth washing varies considerably between different installations; it may be as high as every 10 pressing cycles but it is normally much less frequent, and can be as low as every 200 cycles.

If the effect of lateral flow of filtrate is minimized by ensuring clean plate drainage surfaces, the frequency of cloth washing can be reduced. The frequency can also be affected by the type of cloth, in that an open weave may allow passage of finer particles and build-up on the drainage surface of the plate.

When lime is used, deposits of scale will occur on plate surfaces. This can be removed by high-pressure jetting supplemented occasionally by treatment with a 2-4% solution of inhibited hydrochloric acid.

The filtrate discharge ports must be kept free to allow the maximum filtrate to discharge. The seating of cloths should be checked before closing the press to ensure that there are no folds or creases. The use of torn filter cloths, which may result in sludge solids getting behind the cloth and fouling the plate drainage surface, should be avoided, and care should be taken not to damage the cloths with scrapers.

2.3.5 Performance

Typical performance figures are given in Table 4.

TABLE 4. TYPICAL PERFORMANCE FIGURES OF FILTER-PRESSING PLANTS

		Cycle period (h)	Feed sludge (% DS)	Cake (% DS)	Cake thickness (mm)
Primary/mixed sludge	} 10–30% lime and 5–15% copperas or 1–2% Al_2O_3 or polymers	3–8	4–8	30–40	25–38
Digested sludge		4–12	3–6	30–40	25–38
Thermally conditioned sludge		1.5–4	10–15	35–55	38

Performance may be assessed as throughput of dry solids per unit time, per unit filtration area, or per volume of press capacity.

2.4 Rotary-Drum Vacuum Filter

2.4.1 Introduction

The first vacuum filter, which was designed and patented in 1872 by two brothers, William and James Hart, was similar in many ways to the conventional rotary-drum vacuum filters in use today. Vacuum filtration, however, failed to attract attention for sludge dewatering in the UK until the early 1920s when difficulty was being experienced with dewatering surplus activated sludge by other methods. Experiments were then carried out at Manchester and Sheffield to determine whether chemical conditioning was a satisfactory aid to dewatering.

When the coil vacuum filter was introduced in 1960 a considerable amount of experimental work was carried out using a portable full-scale unit and, as a result, a large number of such units were installed at works throughout the

UK. Particulars of a few of each type of rotary vacuum filter are given in Table 5 (p. 64).

2.4.2 Principle of operation

A rotary-drum vacuum filter consists of a cylindrical drum covered with a filtration medium and rotating partly immersed in a bath of sludge. When liquid sludge is in contact with one face of a filtration medium and a vacuum is applied to the other, liquor is drawn through the medium and a layer of thicker sludge is retained on the outer surface. Application of the vacuum is continued after the medium has been removed from contact with the liquid sludge, dewatering of the layer of sludge adhering to the medium continues, and a cake forms.

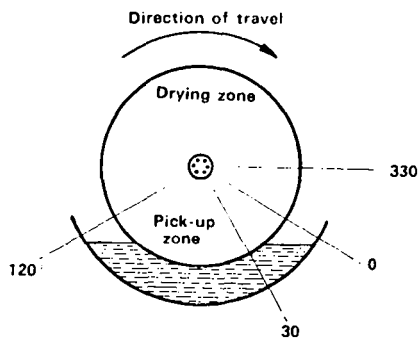

Fig. 13. Diagrammatic representation of sequence of operation of rotary drum vacuum filter

The filter drum is immersed from 0° to 120° in the liquid sludge bath and the section from 30° to 330° is evacuated (Fig. 13). Liquid passes through the filtration medium into the segment of the drum, and solids in suspension are retained on the medium to form the filter cake. The cake increases in thickness as the evacuated section of the drum passes through the liquid sludge in the bath. In the drying zone, air passes with the filtrate through the cake and the filtration medium into the segment drainage system. The air which is carried through increases the velocity of the liquid flow and displaces water from the inter-granular spaces so that the cake gradually dries. Sometimes at about 330° , air pressure may replace the vacuum to loosen the cake before discharge from the drum.

2.4.3 Application

Rotary-drum vacuum filters have been used to dewater all types of sewage sludge and, in common with other mechanical methods of dewatering,

chemicals are usually required for conditioning the sludge. If a digested sludge is being dewatered, elutriation may be used to reduce the alkalinity and the amount of "fines", and thereby minimize the use of chemical conditioners. An important limitation of vacuum filters is that the maximum pressure differential across the filter is equal to 1 atmosphere and, compared with filter presses, the dry solids content of the cake is low. Maintenance costs may be relatively higher and, because there are so many operating variables, an experienced operator is needed to obtain optimum performance. If the cloth is sound, the filtrate from a cloth filter may be relatively free from suspended solids compared with that from a coil filter. The volume of wash water from a coil filter is greater than that from a cloth-covered filter.

2.4.4 Types of rotary-drum vacuum filter

Vacuum filters for dewatering sewage sludge use two types of filtration medium: (a) cloth and (b) stainless-steel coils. Although there are different manufacturers and differences in the details of construction, the principles of design and operation are the same.

2.4.4.1 Cloth-covered filter (Plate 6). A cloth-covered filter consists of a cylindrical drum slowly rotating about a horizontal axis. The drum is made up of segments or compartments of equal size, and is covered by the filter cloth supported on slats. Inside each segment is a plastic drainage grid which ensures maximum distribution of vacuum and allows free drainage. The cloth is held in position by a continuous helical-bound wire, the windings of which are up to 75 mm apart. At each end of the drum, the windings are much closer together in order to form a seal. Copper, phosphor bronze or high-tensile steel wire may be used depending upon the type of conditioning agent.

(a) *Cloths*. In the past, many types of cloth have been used, especially woollen, but in later years there has been a preference for synthetic fibre/wool cloths, sometimes impregnated with anti-rot biocides. Cloths have to be changed because of wear, tear or blinding and it has been found^{53,60} that the operating period of a wool cloth is 1500–2000 h whilst that of a synthetic fibre/wool cloth is 2000–3000 h.

At the West Kent installation⁵¹, the use of a backing cloth of man-made fibre which has a mesh size of about 5 mm has been found necessary, as this enables liquor to be drawn through the whole surface of the filter medium. In the absence of a backing cloth, liquor is drawn mainly through the areas of cloth immediately overlying the perforations in the drum, thus reducing the effective filter area and causing the cloth to blind more rapidly.

- (b) *Sludge bath.* The sludge bath is a semi-cylindrical tank which extends the full width of the filter drum, and the sludge solids are maintained in suspension by an agitator. The sludge level and therefore the depth of immersion of the drum is adjustable.
- (c) *Cake discharge.* As the sludge cake leaves the unit it is guided by a doctor blade which is set tangentially to the drum and may be adjustable or spring-loaded. In some cases, with use, the blade wears and the sharpened edge could remove the nap from the cloth, adversely affecting pick-up, shortening cloth life and damaging the cloth-retaining wires. With a wet cake it may act more as a scraper than a deflector, and a portion of the sludge could be smeared onto the medium and blind the cloth.

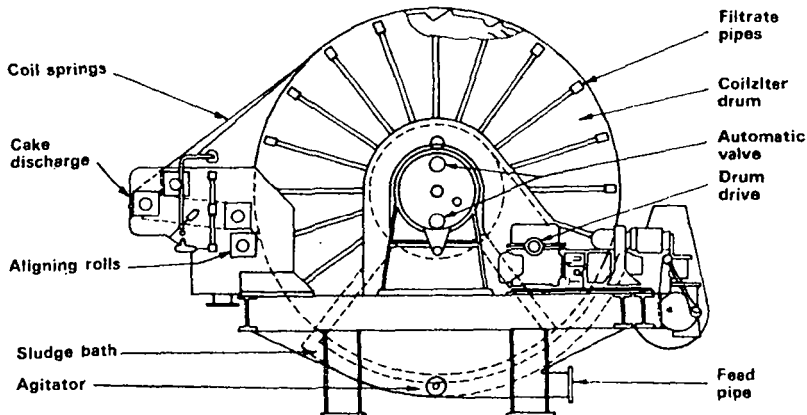

Fig. 14. Diagrammatic arrangement of coil-spring vacuum filter.

2.4.4.2 Coil filter (Fig. 14), (Plate 7). With this type of machine the filtration medium consists of two layers of stainless-steel coiled springs with flexible plastic inserts, and the lower layer rests in circumferential grooves on the drum surface. The cake formation and drying phases are the same as those with the cloth-covered filter, but when the two layers of coiled springs which support the cake are nearing the discharge point they leave the drum and separate. Each layer passes over a separate discharge roller, with the cake being lifted off the lower layer by the upper layer and then removed from the upper layer by a tine bar. After passing over the discharge rollers the coiled springs are cleaned with sprays of water and then are re-aligned by passing over grooved rollers, rejoining the drum to repeat the cycle.

2.4.5 Ancillary equipment

- (a) *Automatic valve.* During the revolution of the drum each independent segment is connected in turn, at the appropriate time, to the vacuum pump, to atmosphere, and, with some cloth-covered filters, to a source of compressed air. Each segment is connected to the vacuum and air through the body of the automatic valve which is cored so that the connections to the pipes are located around the valve periphery. The valve body acts as a pipe manifold for the passage of air and filtrate from each segment to this common point. A bridging wear plate is attached to the valve cover plate which is circular and has radial slots corresponding to the phases of the drum cycle, thereby controlling the passage of air and filtrate through the valve to the pipe to the vacuum receiver.
- (b) *Vacuum receiver.* The mixture of filtrate and air passes through the automatic valve to a vacuum receiver where the filtrate separates from the air, and is withdrawn from the bottom by a centrifugal pump. An automatic float device isolates the receiver in case of over-filling.
- (c) *Vacuum pump.* The pressure differential across the cake and filtration medium varies from 0.40 to 0.60 bar according to the thickness of the cake and the differential in the lower sections of the filter as it rotates may be 0.13 to 0.16 bar higher than in the upper sections. The vacuum pump which creates this pressure differential may be either a reciprocating or a centrifugal pump. When a reciprocating vacuum pump is used there must be a moisture separator between the pump and the vacuum receiver. A centrifugal vacuum pump requires seal water, which is often works' final effluent, and the pump must be equipped with an automatic cut-out to stop the pump if the supply of seal water fails.
- (d) *Wash-water pumps.* High-pressure pumps provide wash water, which could be final effluent, for cloth or coil washing.

2.4.6 Conditioning of sludge (see also Section 1).

Several chemical conditioning agents have been used in vacuum filtration. Lime, usually mixed with iron salts, has had widespread use on coil filters because it is relatively inexpensive. Lime and iron salts are now, however, used less than they were because of the formation of scale which can cause uneven wear on coils and reduces the efficiency of the vacuum system. Aluminium chlorohydrate and polyelectrolytes are in common use because of their effectiveness with a wide range of sludges and because they are more convenient to handle.

The optimum dose of conditioner is found by gradually increasing the rate of addition until a minimum CST is found corresponding to satisfactory performance. If insufficient chemical is added, the solids content of the cake will be low, bare patches may appear on the filtration medium and some blinding may occur; on the other hand excess conditioner could cause the cake to crack and the filtrate to foam.

Addition and mixing of the conditioned sludge must be thorough but gentle because excessive agitation causes the flocs to shear. The importance of the method used for adding and mixing the coagulant was demonstrated on the rotary drum filter at St. Helens⁴⁴ where aluminium chlorohydrate was used for conditioning an elutriated digested mixture of primary and surplus activated sludges.

2.4.7 Operation

2.4.7.1 Start-up. Normal start-up sequence is as follows: (a) wash-water pump (coil filter only); (b) sludge and conditioner pumps; (c) vacuum pump, after bath has filled with sludge; (d) filtrate pump; (e) filter drum; (f) agitator in sludge bath; and (g) cake conveyor.

Chemical feed pumps may be interlocked in the sequence to operate in conjunction with the sludge pump. It is usual to start the filter at minimum speed, increasing it after 2 or 3 revolutions.

2.4.7.2 Routine operation. The routine tasks consist of preparing the conditioning agent, making minor adjustments to maintain the required standard of performance and periodically washing the filtration medium.

During the initial commissioning period of the plant, the operating parameters are established and these must be a compromise between high yield, high solids content, good solids recovery and low conditioner costs. More detailed studies of the theory and practice of operation have been published elsewhere^{84,4,61}.

2.4.7.3 Factors affecting operation. The principal factors affecting the operation of vacuum filters are:

- (a) nature of the feed sludge;
- (b) solids content of the feed sludge;
- (c) addition of chemical conditioner;
- (d) condition of the filtration medium;

- (e) operation of agitator in the sludge bath;
 - (f) drum immersion; and
 - (g) peripheral speed of the drum.
- (a) *Nature of feed sludge.* Primary sludge contains fibrous material which increases the mechanical strength of the cake and enables a thicker and drier cake to be produced. Secondary sludges, digested sludges and stale sludges have a higher chemical conditioner requirement, the solids content of the resultant cake is lower and the yield is reduced. For example, dewatering a digested mixture of primary and activated sludge⁵⁴ conditioned with 5.7% aluminium chlorohydrate (as Al_2O_3), the yield averaged 1.96 kg dry solids/m² h, but when there was no activated sludge present only 1.5% Al_2O_3 was required to give a yield of 7.32 kg/m² h.
- The storage of sludge has a noticeable effect on its filtrability and tends to increase the amount of chemical required for conditioning.
- (b) *Solids content of feed sludge.* When the feed sludge contains more than 7% DS and the solids loading is high, the layer of sludge on the drum is thicker so that the effect of the vacuum is reduced and a wetter cake is formed. This can be a factor contributing towards drop-off, and when this occurs the cake falling back into the sludge bath increases the solids content of the wet sludge.
- (c) *Addition of chemical conditioner.* Before filtration the sludge must be conditioned by adding a chemical coagulant at a dosage rate depending upon the type of sludge and its solids content. The chemical conditioner is normally added to the sludge at a point immediately before it enters the sludge bath.
- (d) *Condition of filtration medium.* Sludge and chemical particles may adversely affect the filtration medium by blinding the cloths or twisting and opening the coils. The efficiency will then be reduced, and routine cleaning must be carried out. Blinding of the outer surface of the cloth may be controlled by the frequency of washing and occasional acid baths, whereas blinding of the inner surface is caused by a scale behind the cloth, which is more difficult to remove.
- (e) *Operation of agitator in sludge bath.* The agitator is suspended in the sludge and is driven gently to and fro at the required rate which prevents settlement of the solid matter from the sludge and assists in producing a feed sludge of uniform consistency. Excessive agitation could cause the flocs to shear.

- (f) *Drum immersion.* The depth of immersion is adjustable within a pre-determined range and changes the period during which pick-up is occurring; the longer this period the shorter will be the cake drying phase. Consequently the effect of increasing the depth of immersion is to increase the thickness of the cake and therefore the yield, but to produce a wetter cake. The fraction of the drum surface (F) immersed in the sludge is calculated⁶¹ from the expression:

$$F = \frac{\text{Cos}^{-1}(h/R)}{180}$$

where h = distance between centre of drum and surface of sludge in the sludge bath, and R = radius of the drum, i.e. the result obtained by dividing the angle, the cosine of which is (h/R) , by 180 degrees.

- (g) *Peripheral speed of drum.* The rotational speed of the drum can be varied, and for any particular installation it is necessary for the optimum to be determined. Increasing the speed reduces the period of a complete cycle, and usually the yield is increased but with a thinner cake; also there may be a tendency for the thin layer to pass below the doctor blade.

2.4.7.4 Control tests. In order to optimize performance, the effectiveness of the conditioning agent has to be measured, and this is usually carried out using the CST apparatus. The performance may be monitored by a conveyor belt weigher, or more simply by using a rectangular tray such as a biscuit tin or similar device to collect the discharge from a known surface area in a certain period of time. Samples of the sludge feed, the cake discharge and the filtrate should be taken regularly and the solids content determined.

2.4.8 Maintenance.

Maintenance involves washing, descaling or renovating the filtration medium and servicing the mechanical and electrical equipment.

In order to reduce the tendency to blinding and thereby reduce the yield, the cloth on a rotary-drum cloth-covered filter needs to be washed regularly. The trough containing the sludge is drained to the sludge sump and the cloth is sprayed for about an hour with jets of water or effluent whilst the drum is rotating. At some works the cloths are rotated through a bath of detergent or, in hard-water areas, inhibited acid at intervals of 1500 h.

Coil filters are equipped with fixed sprays and the coils are washed as they travel from the discharge to the aligning rollers. If the cake is too wet, sludge

is left on the rollers and a poor-quality wash-water is produced. Where lime and copperas are used as conditioners, the coils can become seriously scaled. Descaling may be necessary six times per year in severe cases, and is carried out with proprietary brands of inhibited acid. High-pressure lances are helpful for routine cleaning.

The discharge of wash-water from the filter should be controlled because it could impose a heavy load on the sewage-treatment processes.

2.4.9 Performance

The performance of a rotary vacuum filter (Table 5) is measured in terms of the cake yield in kg DS/m² h, and the SS content of the mixtures of filtrate and wash-water. These can be used in conjunction with the chemical dose to calculate the solids recovery. The proportion of solids recovered depends upon the type of conditioner, the DS content of the feed sludge and the filtration medium. It is usually within the range 85–99.5% and is lower with a coil filter than with a cloth-covered filter. The cake thickness is usually within

TABLE 5. PERFORMANCE OF ROTARY-DRUM VACUUM FILTERS

Works	Sludge	Conditioner (% on dry solids)	Dry solids content (%)		Nominal area (m ²)	Yield (kg DS/m ² h)	Reference
			Feed sludge	Cake			
Cloth-covered filters							
St. Helens	PAD	Al ₂ O ₃ (1.7%)	4	22	32.6	5	44, 53
West Kent	PD	Al ₂ O ₃ (0.5%)	8–10	29–33	29.4	17–25	51
Oxford	PD	Al ₂ O ₃ (1.5%)			27.9	7	52, 62
Coil filters							
Worthing	P	Aquafloc	6	27	35.0	14	54
Worthing	P	Lime (10%) FeSO ₄ (10%)	6	27	35.0	9	55
Jersey	DP	Lime (27%) Al ₂ O ₃	5	19	18.6	18	56
Eccles	PH	Lime & FeSO ₄	5	19	40.0	7–16	57
Morpeth	PH	Lime (18.5%) FeSO ₄ (10.0%)	7	25	23.2	17	58
Esher	PH	Deerborn 4007 (1.4%)	6	21	46.6	19	59

Sludges: P—primary; A—activated; H—humus; D—digested.

the range 3.5–10.0 mm; when it is too thin, the yield is reduced and air may break through, whilst with a thick cake the moisture content may be higher and the yield low. The theoretical yield of feed sludge after conditioning may be calculated from the formula given in Appendix 3.

2.4.9.1 Drop-off. Drop-off is the condition when a portion of the cake taken up on the drum slips back into the sludge bath as it emerges. It can be caused by one or more of the operating variables discussed in Section 2.4.7.3. Increasing the mechanical strength of the cake by using, for example, lime, reduces the tendency to drop-off. Increasing the immersion affects drop-off because this reduces the acuteness of the angle between the surface of the sludge and the filtering medium. Excessive drop-off may result in a loss of vacuum and reduced performance.

2.4.9.2 Filtrate. Filtrate is the liquor drawn through the filtration medium during the pick-up and dewatering phases of the operational cycle. Its suspended solids (SS) content is highest when the filtration medium is first immersed and before the cake has formed, the cake subsequently acting as an additional filter. Worn cloths or damaged coils can increase the SS content of the filtrate.

Increasing the DS content of the feed sludge, improving the conditioning or increasing the immersion of the filter drum, may reduce the SS content of the filtrate. By increasing the speed of the drum or reducing the cake thickness, the SS content of the filtrate may increase.

The filtration medium of a coil filter is more open than that of a conventional filter and a greater proportion of the finer particles in the sludge passes into the filtrate. Table 6 gives some examples of analyses of filtrates from coil filters.

TABLE 6. TYPICAL ANALYSIS OF FILTRATES FROM FILTERS

Works	Sludge	Suspended solids (mg/l)	BOD (mg l)	Reference
Jersey	PD	3130	335	56
Morpeth	PH	400–900	1000–2000	58
Worthing	P(a)	3000	415	54
Worthing	P(b)	2850	515	55

Sludges: P – primary; H – humus; D – digested

(a) Conditioned with lime and ferrous sulphate.

(b) Conditioned with Floccotan (Aqualloc).

Filtrate is usually returned to the inlet of the works to mix with the incoming sewage and, if the rate of return is not too great, it normally has no significant effect on the treatment processes.

2.5 Vacuum Disk Filter

2.5.1 Introduction

The introduction of the vacuum disk filter in 1968 was significant, since the one-disk unit made continuous sludge dewatering available at small sewage-treatment works for the first time. Previously, rural authorities had adopted sludge drying beds as the principal method of sludge dewatering. The advantage of the machine was that it could be mounted on a lorry or trailer for conveyance from one site to another within the rural district, and thus avoid overloading any one small works with excessive volumes of filtrate. Furthermore, it could be operated by semi-skilled labour.

Following the introduction of the mobile one-disk unit, static three- and six-disk units have been installed. Latterly, these machines have proved successful in the dewatering of aerobic digested sludges produced from contact stabilization plants. Plate 8 shows a typical three-disk installation.

2.5.2 Design

The units are supplied complete with sludge-well stirrer, sludge macerator and pumps, dosing pumps and mixer, compressors, vacuum pumps and conveyors. All are duplicated except the stirrer, mixer and conveyor.

The disk unit comprises one, three or six hollow disks, 1.8 m in diameter, mounted on a hollow shaft. The disks are segmented and rotate in a bath of conditioned sludge. When a particular segment is immersed in the sludge, a partial vacuum is applied to the inside of the disk and this causes the solids to adhere to the cloth, forming a cake on each face of the segment. As the segment emerges from the sludge, the vacuum is increased and maintained for half a revolution, causing further dewatering of the cake. A pulse of compressed air is then applied to the inside of the cloth, releasing the cake into a hopper and onto a conveyor belt for discharge. Following the pulse of air, the segment returns to the sludge bath as a vacuum is re-applied.

The filtrate passes through the cloth along the vacuum lines to the filtrate tank before being discharged to the head of the works.

2.5.3 Operation

The sludge to be processed is stored in a well, equipped with a means of maintaining the sludge in a homogeneous state, and this ensures that the minimum of adjustment has to be made during the operating day.

Sludge is pumped from the well via a macerator. The conditioning agent is added, using a dosing pump at either the macerator or the mixer. The most commonly used conditioning agent is a special grade of aluminium chlorohydrate.

The conditioned sludge enters the bath in which the level of sludge is controlled by float switches. Once the sludge operating level has been reached in the bath, the automatic starting system on the panel activates first the compressor and vacuum pump and then the disks and conveyor.

The first few revolutions of the disk produce a low cake yield, mainly as a result of vacuum losses caused by incomplete coverage of the cloths. Once coverage is complete the plant stabilizes and then normally requires little attention from the operator apart from a few visual checks of the machine, sludge cake and filtrate.

2.5.4. Plant variables

2.5.4.1 Conditioning. The optimum dosage rate, determined using the CST apparatus, is found by increasing the rate of dosage until the CST reaches a minimum.

Insufficient conditioning agent results in the production of a wet cake which does not release sufficiently from the cloths, causing blinding. If the level of conditioning agent is too high, the filtrate may foam. Generally a finer grade of aluminium chlorohydrate (ACH) is used, although some trials have been carried out using a polyelectrolyte.

2.5.4.2 Position of chemical injection points. Two chemical injection points are provided, one at the macerator and the other at the mixer. The optimum point must be decided on each individual sludge, but is usually at the mixer, since those flocs formed by the injection at the macerator can shear before reaching the trough on the machine.

2.5.4.3 Speed of mixer. Floc shear can occur if the speed of rotation is too high. This causes the production of a wetter cake which does not adhere easily to the disk.

2.5.4.4 Speed of disk rotation. At high disk rotation speeds, the sludge fails to 'blow-off' properly, owing to the fact that the cake has not drained sufficiently. Prolonged operation at high speeds can cause blinding of the filter cloths.

2.5.4.5 Type of cloth. The original machines were designed to operate using a 480-g staple filament nylon cloth for the dewatering of mixed primary and secondary sludges. Later a felt-type cloth was used for the processing of aerobically digested sludges produced by contact-stabilization plants. However, it has been shown⁶³ at the Adderbury sewage-treatment plant of the Thames Water Authority that plant performance is not affected when processing aerobically digested sludge using the staple filament nylon cloth. After operation for about 1000 h, the cloths need to be replaced, and this condition is identified by poor cake 'blow-off'. Cloths can be washed *in situ* by filling the sludge trough with a mixture of detergent and water, preferably hot, but this is only a temporary expedient. Cloth replacement is a simple operation, as each segment bag can easily be removed and refitted.

2.5.5 Performance

Table 7 gives typical performance figures for mixed raw sludge, using ACH as a conditioner.

TABLE 7. TYPICAL RESULTS FROM A VACUUM DISK FILTER USING RAW SLUDGE

% DS in feed sludge	Dosage* (kg/tonne)	% DS cake
2.9	179	15.0
3.9	83	17.7
4.6	69	15.3
5.3	65	17.4

* expressed as Al₂O₃

2.6 Filter Belt Press or Band Filter

2.6.1 Introduction

In 1873 Milburn and Jackson⁶⁴ patented a filter belt press and one unit was installed at Coventry⁶⁵ in 1874. It was basically similar to the machines in use today, except that it used belts of hinged metal plates, the lower belt being covered with felt or cloth. In 1921-22, a filter belt press was used experi-

mentally at Manchester⁶⁶ for dewatering activated sludge. In 1924, Wood⁶⁷ patented a machine for dewatering pulverized coal which used coconut matting for the belts.

During the following forty years, several patents were taken out for filter belt presses, notably by Morgan⁶⁸, who used an absorbent material for the cloths, with the expectation that this would assist the dewatering, and by Goodman⁶⁹ and Schover⁷⁰, whilst other machines were developed for dewatering screenings⁷¹.

In 1966, Klein⁷² patented a belt press which is seen as the forerunner of the current machines. The first machine to be installed in the UK was at Lenham in 1972⁷³ using polyelectrolyte as a conditioning agent. The original Klein machine was simple in concept and this design has now been further developed by many manufacturers to produce machines having greater throughputs, more flexibility on the type of sludge to be dewatered and a capacity to produce drier sludge cakes. The multi-roller machines show some resemblance to paper-making machines to which they owe their origins.

2.6.2 Mechanism

Liquid sludge, which has previously been conditioned by the addition of a polyelectrolyte, is discharged onto a moving, open-mesh, endless belt, which acts as a drainage medium. The dewatering occurs in three basic zones (Figs. 15 and 16).

- (a) *Free draining.* That which occurs immediately the conditioned sludge is discharged onto the filter belt and before any pressure is applied to the

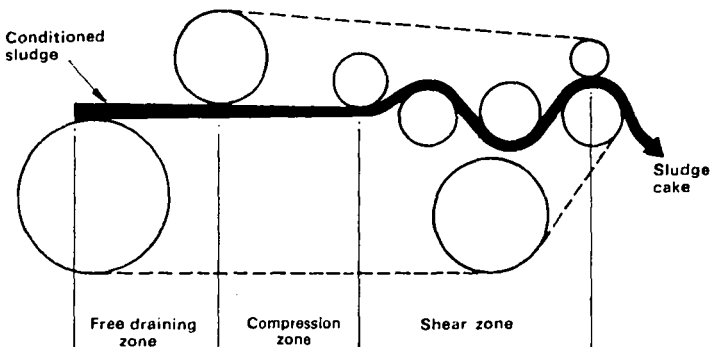

Fig. 15. Schematic layout of filter-belt press.

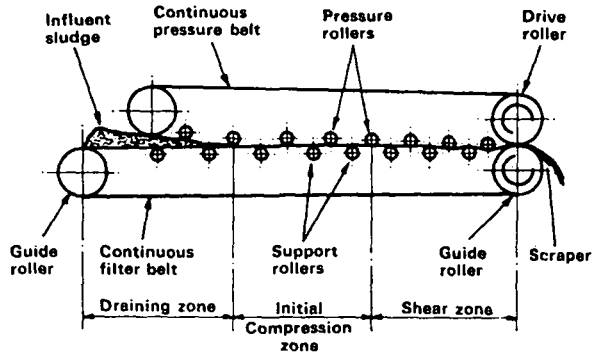

Fig. 16. Simplified arrangement of layout of filter-belt press.

sludge layer. The released water drains rapidly, and vacuum can be applied to assist drainage.

- (b) *Initial compression.* That which occurs when a low pressure is applied to the sludge, either by a convergence of a press belt onto a filter belt or by a separate belt. This accelerates the removal of the remaining free-draining water and compresses the sludge layer so that, being more cohesive, higher pressures can be applied without the sludge being squeezed out of the machine.
- (c) *Final compression and shear.* That which occurs when the sludge is subjected to increased pressure and a shearing effect. This opens new channels in the sludge 'sandwich', enabling more water to be released.

The filtrate from all three sections is collected under the machine, together with the belt washings, and returned to the sewage-works inlet.

2.6.3 Application

Filter belt presses can be used to dewater the sludge produced by a sewage-treatment works of any size: the larger machines have belts up to 2.5 m in width and can process sludge at rates in excess of 13 m³/h. As with other forms of dewatering equipment, filter belt presses operate most efficiently when processing primary sludges, but are also effective in dewatering mixed sludges or even secondary sludges alone. The throughput and DS content of the cake decrease as the proportion of secondary sludges increases.

The machines are slow-running and are therefore fairly quiet in operation. The progress of the sludge through the first section is usually visible which

allows the operator to make minor running adjustments. Since the sludge is exposed, any odours present in the sludge can escape into the building which houses the machine. Sulphide odour problems have been overcome by dosing the feed sludge with hydrogen peroxide or lime. The presence of excessive amounts of hydrogen sulphide can, in addition to being a health hazard, cause severe corrosion of metal components, particularly those made from copper or brass.

2.6.4 Design

A filter belt press (Plate 9) (Fig. 16) consists of two endless belts: an upper press belt and a lower filter belt, which converge to produce pressure on the sludge layer formed on the filter belt. At the discharge end of the machine, a doctor blade lifts the sludge cake from the belt. The belt is then washed with high-pressure water or effluent sprays before returning to the sludge application point. Filtrate can also be used for belt washing.

The operation is monitored by a cake-sensing device which stops the machine if the discharge of cake from the doctor blade is interrupted, on the basis that if no cake is being produced, then either the belt drive or one of the feed pumps has either stopped or become blocked.

2.6.4.1 Belts. Belts can range in width from 0.5 m to 2.5 m. Filter belts can be manufactured from stainless steel or polyester mesh, whereas press belts are usually made from nylon-reinforced rubber. A more recent innovation is to use filter fabric for both belts as this doubles the drainage surface and also tends to hold the sludge 'sandwich' more firmly. Generally, two endless belts are used in each machine, although an additional short length of belt may be used to form the initial compression zone.

Each belt is kept running at right angles to the rollers by a steering roller which is controlled by hydraulic rams. These react to signals transmitted from limit switches located at each side of the belt which sense when a belt is moving off track.

2.6.4.2 Draining zone. Since the sludge fed to the belt has been conditioned with a polyelectrolyte, it consists of large conglomerate flocs and separated water, which drains rapidly through the belt. Some machines apply a low vacuum at this stage to improve the free drainage, with the claim that this can reduce the polyelectrolyte dose rate. Other machines incorporate a sieve-drum mechanism between the mixer and the belts to remove most of the free-draining liquid, and thus act as an alternative to the draining zone. This enables sludge containing up to 12% DS to be fed onto the belt.

2.6.4.3 Initial compression zone. In this zone the sludge layer is subjected to a low pressure, formed by the convergence of two belts, which evens out the layer to ensure complete coverage of the belt so that a parallel 'sandwich' enters the final stage. The low pressure also squeezes out more of the easily separated liquid contained in the sludge.

2.6.4.4 Final compression and shear zone. As belt presses are incapable of sustaining pressures as high as those produced in filter presses, the liquid retained in the sludge is removed by applying a combination of pressure and shear. This is achieved by passing the sludge 'sandwich' around a series of rollers, which has the effect of producing high instantaneous pressures (thereby shearing the outer layers of the sludge) and opening up new channels. It has been noted that the shearing effect is more pronounced if the diameter of the rollers is progressively reduced through the machine, which also progressively increases the pressure achieved.

2.6.4.5 Types of machine. Since the early machines did not have a true high-pressure or shear zone, the sludge path was not distorted to any great extent. Later machines introduced more rollers to increase the shear and pressure. Other techniques for increasing both shear and pressure have been tried, including vertical belts, spring-loaded rollers and caterpillar tracks. However, the most commonly used machines fall into three main categories which are represented in Figs. 16, 17 and 18.

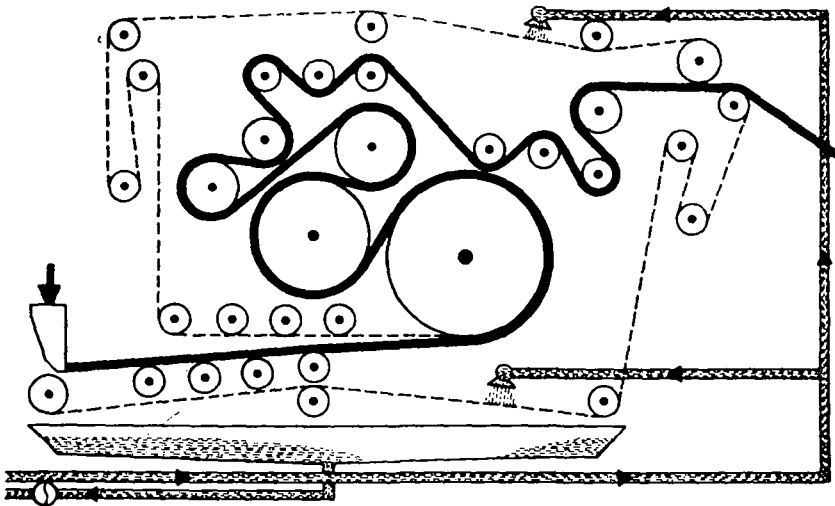

Fig. 17. Multistage/incremental pressure increase type filter-belt press.

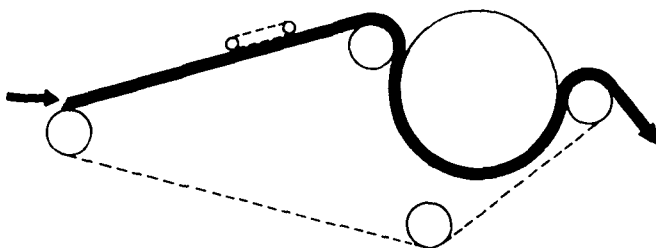

Fig. 18. Drum type filter-belt press.

2.6.5 Operation

2.6.5.1 Start-up. The start-up sequence is often operated from a single button, the sequence being controlled by timers in the control panel. The usual sequence is (a) sludge conveyors; (b) filter belt drive; (c) filter belt wash-water pump; (d) polyelectrolyte pump; (e) sludge pump/macerator; and (f) sludge mixer.

When closing down the plant, the feed pumps, mixer and conveyor are shut off, but the belt and belt-washing system continue to operate for a period to ensure that the belt is shut down in a clean condition. If sludge is allowed to dry on the belt fabric, the filtering characteristics of the belt could be changed.

2.6.5.2 Routine operation. If the feed-sludge solids content is consistent, then after setting-up, the machine may be left unattended for long periods. Timers are often fitted which enable the machine to run unattended after the operator has left the site. When the timer operates, it shuts down all motors except the belt drive and belt-wash units so that the machine is clean, ready for the next operation.

In order to avoid problems caused by rags, plastics and other debris, it is essential that the sludge is either screened or macerated before being pumped to the machine. When raw sludge is being processed, the addition of hydrogen peroxide or lime may be useful in suppressing obnoxious sulphide odours.

It should be noted⁷⁴ that hydrogen sulphide is extremely toxic, therefore all sludge dewatering buildings need to be well ventilated.

Optimum operating conditions are normally established during commissioning and, therefore, only minor adjustments need to be made to compensate for variations in sludge quality. The operator can observe the effect of any adjustments and then rapidly re-establish optimum conditions.

2.6.5.3 Operational variables.

- (a) *Nature of feed sludge.* Different sludges vary in their amenability to dewatering, and typical results are given in Table 8.

TABLE 8. RESULTS OBTAINED FROM FILTER BELT PRESSES WITH DIFFERENT TYPES OF SLUDGE

Type of sludge	Conventional press	Multistage press
	(% DS in cake)	(% DS in cake)
Mixed raw/humus	15-25	25-35
Anaerobically digested	18-25	25-35
Activated	12-15	16-22
Aerobically digested	15-18	18-20

High levels of grease in the feed sludge can cause blinding of the belts, particularly if the pressure of the wash-water decreases.

- (b) *Solids content of feed sludge.* Thickening of sludge before it is fed into the machine may enable the polyelectrolyte dose rate to be reduced and an increase in solids throughput achieved, which on a large installation could show a capital cost benefit as fewer machines would be required.

If the thickening process is prolonged, any benefits accruing will be counteracted by the increased age of the sludge together with additional problems caused by septicity.

- (c) *Age of sludge.* The freshness of the sludge is an important factor when dewatering raw sludges. A fresh sludge is more amenable to dewatering than an older sludge which will require more polyelectrolyte to achieve the same degree of flocculation. An older sludge is also more likely to produce odour problems during the dewatering process.

If insufficient polyelectrolyte is used and large conglomerate flocs are not formed, complete free drainage does not occur and the sludge may be squeezed out of the sides of the belt in successive stages. Conversely, the excessive use of polyelectrolytes may result in blinding of the filter cloths. The value of laboratory tests to evaluate the effectiveness of a polyelectrolyte in a filter belt press, and thus the performance of that press, has been discussed by Baskerville, Bruce and Day².

- (e) *Mixer speed.* With machines that incorporate a drum mixer, which is similar in action to a concrete mixer, the rotational speed of the drum can affect performance. If the speed is too slow, insufficient mixing of the polyelectrolyte and the sludge results in a poorly conditioned sludge; conversely, at high rotational speeds, the sludge flocs can be sheared before they are discharged onto the belt.
- (f) *Rate of sludge input.* In order to utilize the machine fully, the rate of sludge feed to the belt must ensure that the full width of the belt is completely covered with sludge. If too much sludge is applied to the belt, sludge may be squeezed out from the sides of the belts and into the filtrate receiver.
- (g) *Belt speed.* The throughput of sludge is generally related to the speed of the belt. At high belt speeds, generally a wetter cake is produced but at a higher solids throughput rate. For lower belt speeds the cake is drier but the solids throughput is lower. Thus any setting of the belt speed is a compromise, depending upon the sludge disposal requirements.
- (h) *Free-draining zone period.* Ideally, all free-draining liquid should have drained from the sludge before it enters the initial pressure zone. If the free-draining period is too short, the sludge entering the high-pressure zone is too wet and may be squeezed out from the sides of the machine. The free-draining period can be increased either by reducing the belt speed or raising the rollers of this section to prevent the belts converging too soon.
- (i) *Belt washing.* Inadequate belt washing will result in blinding and a deterioration in performance, as filtrate can no longer pass through the belt. Washwater may be drawn either from a mains water supply, a recycled final effluent or the drainings from the sieve drum arrangement used in some machines. In all cases the washwater is applied within the machine at high pressure so that the solids are washed down into the filtrate collection tray. It should be noted that this high-pressure spraying of washwater can produce an aerosol effect which may be offensive to operators, depending upon the source of washwater.

2.6.5.4 Control tests. Generally the only control tests required are for the solids content of the feed sludge, the sludge cake and the filtrate. With many machines, a separate sample of filtrate is difficult to obtain, and in this case a sample is taken of the combined filtrate and washwater. However, this would

affect the mass balance calculation for solids recovery as the volume of belt washings is significant: this is generally known and is a constant during operation.

2.6.6 Maintenance

As the speed of the moving parts is low, maintenance is generally not a problem. Replacement of belts can be difficult, depending upon the complexity of the machine, and could be expensive, but would not appear to be a frequent operation unless large particles are allowed to be discharged onto the belt where they can cause damage.

Grit in the sludge will reduce the life of both the macerator and pumps serving the machine, in addition to the belt itself.

TABLE 9. RESULTS OF EXPERIMENTAL TRIALS ON FILTER BELT PRESSES²⁷

Type of sludge	DS content (%)		SS in filtrate/ beltwash unit (mg/l)
	Feed	Cake	
Raw primary/humus	3.2-11.2	17.6-32.6	270-3780
Raw primary/act.	2.4-4.6	16.8-20.7	280-1650
Cold digested	7.7-6.3	21.1-29.1	1500-3500
Heated digested	1.9-4.1	17.9-25.7	100-450
Surplus activated	1.4-2.3	12.6-15.9	210-300

TABLE 10. RESULTS OF EXPERIMENTAL TRIALS ON A MULTISTAGE FILTER BELT PRESS²⁸

Type of sludge	DS content (%)		SS in filtrate/ beltwash unit (mg/l)
	Feed	Cake	
Raw primary humus	2.6-7.5	22.6-39.4	196-1640
Raw primary/act.	4.0-5.7	23.2-35.5	525-3000
Heated digested	4.1-5.9	26.0-37.9	187-814
Surplus activated	1.0-2.8	16.6-22.1	260-730
'Carousel'	2.1-2.7	18.6-28.2	—
High-rate filter	1.5-1.6	14.7-16.5	208-272

2.6.7 Performance

There are few published results showing the operation of belt presses; however, manufacturers and plant operators^{63,75,76,77} have been helpful in providing operational data (Tables 9 and 10).

2.7 Centrifuge

2.7.1 Introduction

Centrifuges have been used for sludge dewatering since 1855, when one or more perforated basket centrifuges were installed at Leicester. Between 1868 and 1872 further machines were commissioned at Leamington and Hastings by the Native Guano Company; however, none of these were successful and they were soon superseded by other dewatering methods.

Following the introduction of the activated-sludge process, centrifuges were tried at Manchester and other places for thickening of surplus sludge, but as only inorganic chemicals were available for conditioning the sludge it was not possible to obtain either a satisfactory cake or a good-quality centrate. More recently, centrifuges have been successfully used for this function (see: Sewage Sludge I).

In the 1930s, the solid-bowl conveyor sludge centrifuge was developed in the USA and this achieved a higher level of success with sewage sludges.

It was not until the late 1960s, when polyelectrolytes were introduced as conditioning agents, that centrifuges became a viable method of sludge dewatering, as the use of polyelectrolyte enabled a centrifuge to produce both a good solids recovery and a dry cake.

More recently, centrifuges have been sold in 'palletized' form, each pallet comprising a complete assembly which only requires the services to be connected.

2.7.2 Mechanism

A centrifuge is a mechanical device which employs centrifugal forces within a process stream, thereby enhancing the settling rates of particles. It consists of a rotating bowl into which the sludge and polyelectrolyte are injected, and the rotating action of the bowl causes the solids to separate out on its periphery. In the solid-bowl centrifuge the internal scroll assists the discharge of the solids.

A centrifuge performs two functions: clarification and sludge thickening. The traditional theory of scale-up, i.e. the Sigma concept⁷⁸, relates to the clarification function and is discussed in Appendix 4. More recently, Vesilind⁷⁹ proposed the Beta theory which considers the sludge-thickening function of the centrifuge (Appendix 4).

2.7.3 Application

Compared to batch sludge-dewatering machines, centrifuges require a much smaller building to dewater the same volume of sludge; therefore the civil engineering requirement is considerably lower. Also, once the main input parameters have been fixed, they require minimal adjustment; thus the manpower requirement is lower than for a batch machine which requires considerable attention.

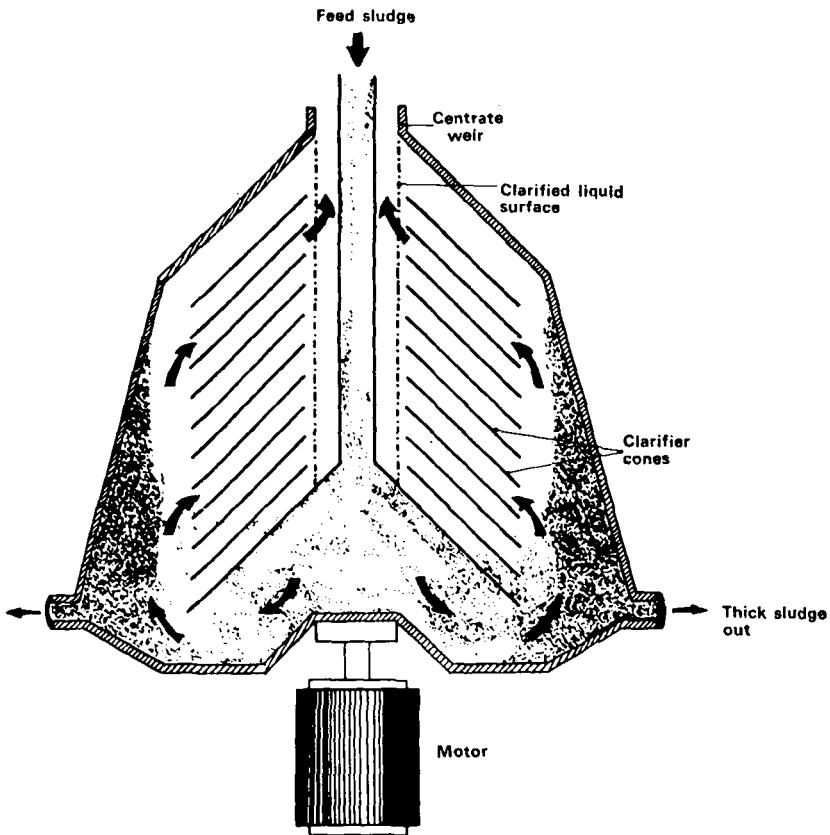

Fig. 19. Diagrammatic representation of nozzle-bowl centrifuge.

The cake produced by a centrifuge operating on raw sludge normally contains 18–25% DS; however, drier cakes can be obtained but the chemical costs may be prohibitive.

2.7.4 Nozzle-bowl centrifuge (Fig. 19)

This is a continuously operated machine and is mainly used in sewage treatment for thickening activated sludges, when they achieve a thickening to over 5% DS without the use of conditioning agents.

The sludge is injected into the rotating conical bowl, and the solids, after being collected on the bowl wall, are discharged through the nozzle ports. The separate liquid passes through conical disks which act in a manner similar to inclined plates to increase the effective settling area and thus improve the settling performance.

These machines cannot be used to dewater thicker sludges since the high concentration of SS in the centrate would cause blockages in the disk paths; however, they can be used for improving the quality of centrates from other centrifuges.

2.7.5 Solid-bowl scroll discharge centrifuge (Plate 10)

This is the centrifuge most commonly used for dewatering sewage sludges, and interest in these machines as a method of sludge dewatering came to prominence only after the introduction of polyelectrolytes.

Sludge is injected, along with the polyelectrolyte, into the centre of a horizontally rotating bowl; the tapered section provides a 'beach' for the extracted solids to dewater further before discharge from the machine. A

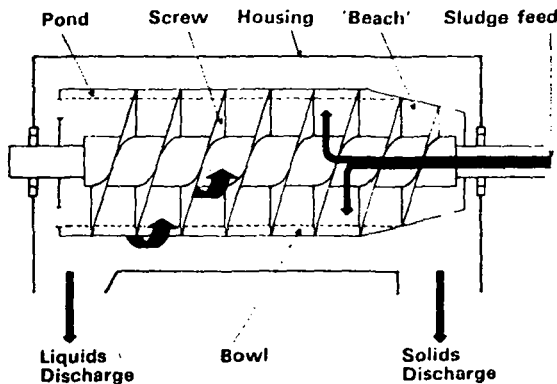

Fig. 20. Diagrammatic representation of solid-bowl scroll centrifuge.

scroll conveyor, mounted inside the bowl and rotating at a speed slightly different to that of the bowl, conveys the solids towards and onto the beach and finally out of the discharge ports.

Fig. 20 shows a cross-sectional view of a typical scroll conveyor centrifuge and identifies the two principal zones of the process: the liquid zone where the separation occurs and the drying zone where the flocs are conveyed up onto the beach for further dewatering before discharge from the machine.

Units of this type can normally achieve a 20–25% DS content in the cake, depending upon the type of sludge processed.

2.7.5.1 Design

(a) *Dimensions.* The relationship between length and diameter is important, the optimum ratio being in the range 2.5–4.0 : 1. The higher the ratio the greater the clarification.

The effect of increasing the bowl length is to increase the settling area and thus the retention period without affecting the centrifugal forces. This does not apply when the bowl diameter is increased in an attempt to increase retention period, which would have the effect of increasing the volume of the pond. However, as the bowl diameter increases the rate of speed decrease is greater than the rate of diameter increase, therefore the larger diameter bowl machines operate at lower centrifugal forces. As a general rule an increase in the bowl length increases the clarification capacity and hence the centrate quality. An increase in bowl diameter can increase both the scrolling and clarification capacity and hence the centrate and cake quality.

(b) *Pond depth.* This is the operating depth of liquid within the bowl of the centrifuge, and is controlled by the adjustment of weir plates on the centrate overflow ports, which can easily be carried out when the machine is stationary. If the pond depth is reduced, more of the beach is exposed and a drier cake is produced. Increasing the pond depth increases the retention period in the pond and produces a clearer centrate. However, this is usually at the expense of cake dryness as a shorter beach draining period is available. With a deeper pond, the effect of the scroll is reduced as, using a shallow pond, the scroll tends to redisperse some of the finer settled solids. Fig. 21 (p. 85) shows the effect of pond depth on recovery and cake solids, for a typical sludge⁸⁰.

- (c) *Bowl speed.* The greater the speed of rotation of the bowl, the greater the 'G' or centrifugal forces within the bowl, leading to improved settling of solids and improved drying on the beach. Fig. 21 shows the variation of cake dryness with speed of bowl.

Bowl speeds used in practice are a compromise to produce the optimum combination of clarification, throughput, cake dryness, chemical and maintenance costs. It has been found that for sewage sludges the optimum range for 'G' forces is 750–2000. This 'G' force (F) produced by a centrifuge can be calculated from the bowl diameter and its speed of rotation:

$$F = \frac{6.5 N^2 D}{10^7}$$

where N = bowl speed (rev/min)

D = bowl diameter

F = centrifugal force as a factor of the terrestrial gravitational force = 'G' force.

The derivation of this formula is discussed in Appendix 5.

The higher the value of F, the drier the cake and the greater the liquid clarification. To avoid shearing the sludge flocs the 'G' force should not exceed 10 000. On-site adjustments of bowl speed are made by changing the belt-drive pulleys until the optimum is found.

- (d) *Beach angle.* The beach is the tapered section of the bowl and provides a dry area above the liquid level where drainage can occur.

The solids that separate out in the peripheral section of the bowl are scrolled up the beach against the flow of water draining down the beach and the centrifugal force. Therefore, if the rate of scrolling is too high or the angle of the beach is too steep, the counter-current of water will wash these solids back into the liquid zone (slippage).

Albertson and Guidi⁸¹ produced a theory showing the effect of beach angle in 'conveyability' of the solids (see Appendix 5).

The angle of the beach is predetermined by the manufacturer of the bowl and this is not a plant variable in the sense that it can be adjusted on site.

If conveyability of the solids proves to be a problem, either:

- (a) the bowl speed would need to be reduced;
- (b) the pond depth increased;
- (c) the scroll surface finish improved; or
- (d) the differential bowl speed reduced.

2.7.5.2 Scroll

- (a) *Design and construction.* The scroll fits the internal contours of the bowl with a clearance of about 1 mm and rotates at a different speed to that of the bowl itself. The difference of a few revolutions per minute is sufficient to scroll the solids out of the liquid phase onto the beach and out of the machine.

Although the individual design of a scroll is a central element of centrifuge design and manufacture, there is little information published on this aspect. The scrolls used for sewage sludge tend to have a wide pitch to prevent bridging of the solids, even though a smaller pitch would tend to reduce the degree of spiral travel and decrease the risk of slippage. Slippage can also be reduced by holes in the flights at their junction with the scroll, which facilitate a counterflow of liquids. The scroll is generally manufactured by welding semi-circular flights onto the central drum shaft. The edges and leading faces of these flights are hardened or tipped with stellite or a nickel carbide to prevent erosion due to the abrasive action of the sludge. The life of these tips varies from 6000 h to 12 000 h. Before installation the scrolls are balanced both dynamically and statically to reduce noise and prolong the life of the machines.

- (b) *Drive.* There are two main types of differential gearbox currently in general use for driving the scroll at a speed slightly different to that of the bowl:
- (i) *Planetary type* — these are preferred for larger machines as they are better at transmitting high loads, and are favoured for high-density sludges. The gearbox contains 'sun and planet' gear trains.
 - (ii) *Epicyclic type* — these are generally more favoured by European manufacturers and consist of an eccentric notching device which, when connected to the auxiliary drive, allows the speed of rotation of the scroll to vary by the small difference in rev/min.

One UK manufacturer uses an epicyclic planetary gearbox, with an efficiency of 95%, and 'cycles' the torque around a closed loop so that torque developed in the conveyor shaft is offset by torque developed in the bowl hub.

Whatever the type of gearbox used, a torque overload device is fitted to protect the gearbox, should the scroll jam. Some manufacturers offer torque monitoring and alarm devices.

- (c) *Speed.* The scroll rotates at a speed different to that of the bowl; usually at a slightly slower speed when using planetary gearboxes and at a higher speed when using epicyclic gearboxes. The difference in the speed is in the range 5-80 rev/min, infinitely variable. This is controlled by an auxiliary pulley on the main gearbox, operated either by a drive from the main motor or from a separate smaller motor. Some units incorporate an 'eddy-current' brake (not to be confused with a motor) which allows infinitely variable speed control of the gearbox pinion shaft.

The difference in the scroll speed is important to the production of a satisfactory centrate and sludge cake. If the difference is too low the retention period on the beach is increased and a drier cake is produced, which can ultimately cause the ports to block up with solids. A lower speed difference has the benefit of reducing turbulence, which increases solids recovery levels, and also the lower speed difference reduces the wear on the scroll. Conversely, a higher speed difference generally produces a wetter cake, although with certain types of sludges, the increased speed can wash out the fines and produce a drier cake albeit at the expense of lower recovery of solids.

It is important that the capacity of scrolling solids out of the centrifuge must be equal to or greater than the rate of solids input.

2.7.5.3 Sludge feed zone. In this zone the sludge enters the machine and is accelerated up to the rotational speed of the bowl. It is important that this operation is carried out efficiently without the solids separating from the liquid as blockages can occur. One type of centrifuge employs an inner screw to assist the acceleration of the solids.

2.7.5.4 Flocc zone. At this point flocculant is injected into the sludge. Injection must be at a point to enable a sufficient period of reaction for the sludge flocs to form and then ensure that they are not subjected to forces likely to cause substantial shear, which would result in a wet cake. Different

polyelectrolytes have a different reaction period. Anionic polyelectrolytes have a slower reaction period and are generally dosed upstream of the machine, whereas cationic polyelectrolytes with their faster reaction period are usually added within the machine. For most sludges, cationics are preferable as they produce flocs more resistant to shear, also because most particles suspended in water carry a negative charge.

2.7.6 Operation

2.7.6.1 Start-up. Normally, the start-up sequence of centrifuges is automated and controlled by a series of timers and interlocks in the control panel. The usual starting sequence is as follows: (a) lubricating oil pumps (if fitted); (b) bearing-seal water pump (if fitted); (c) cake conveyors (if fitted); (d) centrifuge; (e) chemical pump; (f) sludge pump/mutator. The chemical and sludge pumps will not start until the centrifuge has reached full speed.

The sequence is reversed when shutting down the machine. It is essential that at the end of each run the centrifuge is flushed out with clean water and that this is carried out whilst the centrifuge is still running. Most installations fit a flush tank for this purpose.

2.7.6.2 Routine operation. A centrifuge installation is relatively simple to operate and is well within the capabilities of a semi-skilled operator, who can be trained for the tasks, provided that the sludge feed solids concentration does not significantly vary. The level of feedback of information dictates the degree of supervision required.

In order to avoid problems caused by the centrate discharge ports becoming blocked with rags and plastics, it is essential that the sludge is well screened or macerated before being pumped into the centrifuge.

As the process variables are established by the machine manufacturers during their process commissioning, normally only minor adjustments need to be made daily to the input rate settings. One of the most easily used guides for the efficiency of operation, apart from cake quality, is the quality of the centrate. At optimum levels, the centrate should be white or pale grey. If the centrate foams, the polymer dose rate needs reducing, either by increasing the sludge flow or decreasing the polyelectrolyte flow. The operation can be automated using the solids content of the centrate as a parameter.

2.7.6.3 Operational variables

- (a) *Nature of feed sludge.* Different sludge types vary in their amenability to dewatering by centrifuge, and Table 11 shows typical results obtained from various sludges.

TABLE 11. RESULTS OBTAINED ON CENTRIFUGING VARIOUS SLUDGES

Type of sludge	Feed solids (%)	% Recovery
Raw	4.4-9.2	94-99
Raw + humus	2.5-6.2	94-99
Raw + activated	2.3-7.1	95-99
Digested	3.5-4.1	85-99

With raw sludges, the higher the content of fibrous matter in the sludge, the easier the sludge is to dewater. This was found to be the case when centrifuge trials were carried out at Banbury⁸², where the sludge contained a large proportion of fibrous matter owing to the presence of high levels of cattle-market effluent. High levels of grease in the feed sludge can cause operating problems as the grease tends to build up in the outlet ports and eventually block them.

- (b) *Solids content of feed sludge.* Thickening of sludge before dewatering may enable the polyelectrolyte dose rate to be reduced and the throughput of solids to be increased. Therefore there may be a cost benefit to be obtained from feeding a thicker sludge to a centrifuge, as the polyelectrolyte requirements could be considerably reduced.

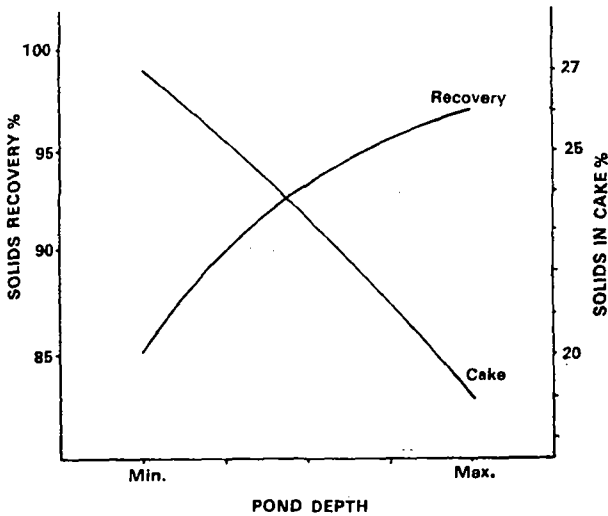

Fig. 21. Effect of pond depth on recovery.

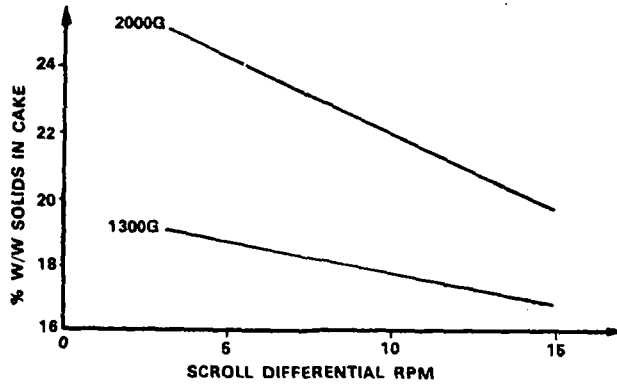

Fig. 22. Variation on dryness of cake with speed of bowl for a typical sludge.

If sludge can be thickened, there could be a reduction in the capital requirements, as either a smaller machine or fewer machines may be required. Fig. 23 shows the effect of sludge feed solids on solids recovery for a typical sludge⁸⁰.

- (c) *Sludge age.* When dewatering raw sludges, either alone or in admixture with secondary sludges, the age of the sludge is important, as a fresher sludge is more amenable to centrifugation. To obtain a similar performance with an older sludge, a higher polyelectrolyte dose would be required.

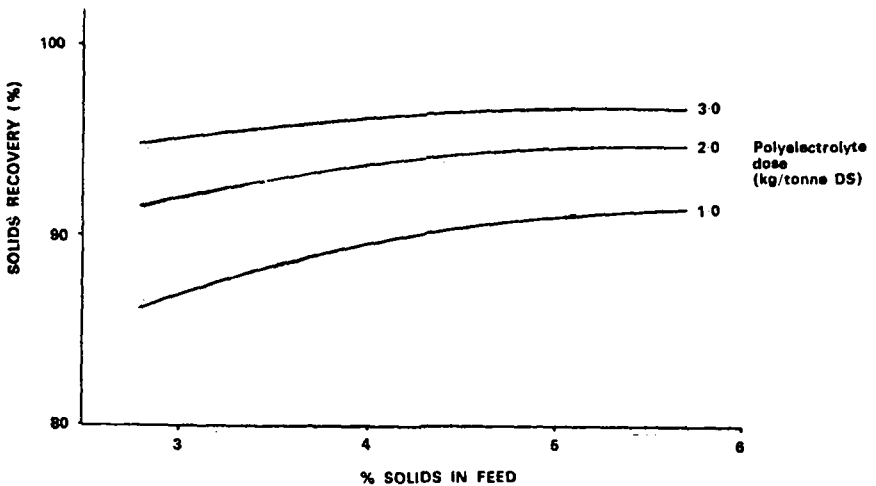

Fig. 23. Effect of sludge feed solids on solids recovery.

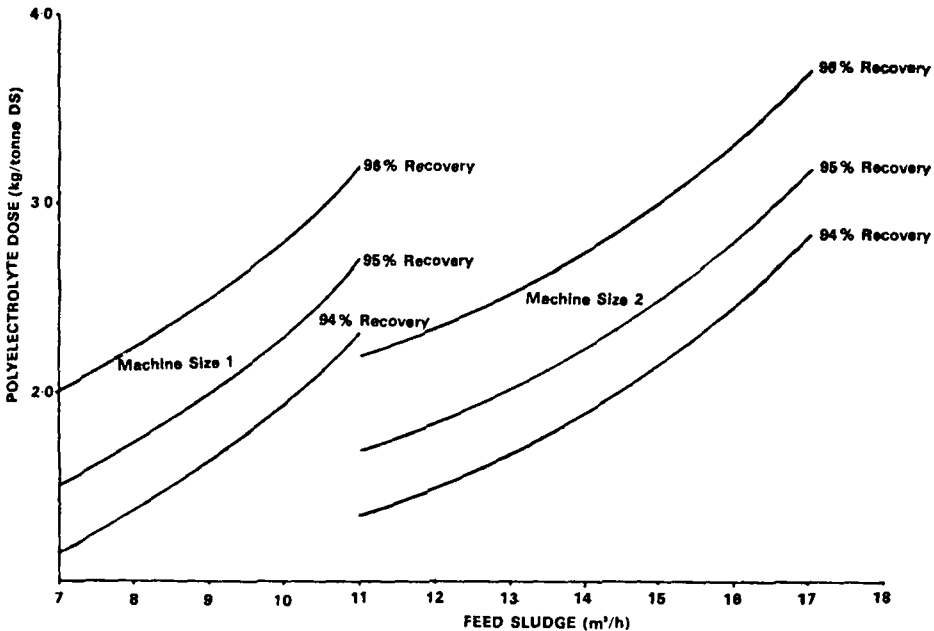

Fig. 24. Typical polyelectrolyte dosage rates.

- (d) *Polyelectrolyte addition.* For operating purposes, polyelectrolyte is generally used as a 0.10–0.15% solution. Generally, powdered polyelectrolytes are mixed using an eductor (Fig. 8), which rapidly disperses the powder. Polyelectrolytes prepared in this way need 'ageing' for 30–60 min before use to ensure that all the polymer is dissolved.

The effect of polyelectrolyte dose rate on recovery (Fig. 24) was demonstrated by the trials carried out at Lockerbie by the Scottish Development Department⁸⁰, where the peak recovery was achieved at the dose rate of 2–3 kg/tonne DS using Zetag 92.

- (e) *Pond depth, bowl speed and scroll speed differential.* These have already been discussed in Section 2.7.5.
- (f) *Rate of sludge input.* The rate of sludge feed affects the retention period in the centrifuge and hence both the quality of the centrate and the cake dryness. At a high feed rate, the solids recovery is reduced because fines are washed out of the sludge and into the centrate, but a drier cake is sometimes produced. The nature of the sludge feed is

critical and should be at a constant rate; therefore ram pumps are not desired for feeding, and other positive displacement pumps have to be used.

Fig. 24 shows the variation of dose rate with feed rates at constant recoveries for one given centrifuge. The curves also demonstrate the importance of selecting a machine with adequate capacity and the flexibility of centrifuges for accepting higher loadings.

2.7.6.4 Control tests. Generally, the only control tests required are for the solids content of the sludge input, the sludge cake and the centrate. Knowing these, the performance of the centrifuge can be calculated by determining the rate of recovery of solids:

$$R = \frac{(S_f - S_e)}{S_f} \times 100$$

where R = % solids recovery

S_f = % dry solids in feed sludge

S_e = % dry solids in centrate

A full derivation of this expression is given in Appendix 5. However, where a machine is being fed with sludge containing high solids and where high polymer dose rates are being used, the above formula can be inexact owing to the difference between feed and centrate rates.

2.7.7 Maintenance

The speed of rotation of a centrifuge is much faster than that of most other types of machinery used in sewage treatment. However, as centrifuges have been designed to operate at these higher speeds, the level of maintenance is normally no more expensive than for other rotating machines.

The life of a scroll varies between 6000 h and 12 000 h, depending upon the concentration of grit in the sludge. It is advisable to check the condition of the scroll every 3000 h as, if there is excessive wear on the scroll, it will need re-hard-surfacing followed by dynamic balancing.

The concentration of grit in the sludge will also affect the life of the sludge macerator, if fitted, which feeds the centrifuges.

Maintenance of ancillary moving parts is a fairly simple operation and may be carried out by in-house maintenance staff. In larger, better-equipped workshops, it may even be possible to resurface the edges of scrolls.

2.7.8. Performance

There are few published results showing the operation of centrifuges on raw sludge and fewer comparable results for digested sludges. The most impressive figures for raw sludge are those of the trials carried out at Banbury⁶³ when five different manufacturers' machines were tested simultaneously. Some published results^{83,84} are summarized in Table 12.

TABLE 12. EXPERIMENTAL RESULTS USING SURPLUS ACTIVATED SLUDGE^{83,84} AND DIGESTED SLUDGE⁶³

	Surplus activated			Digested		
	Average	Range		Average	Range	
		Min.	Max.		Min.	Max.
Feed sludge flow (m ³ /h)	6.4	4.0	8.5	7.6	6.7	8.9
Feed sludge (%)	0.92	0.70	1.0	4.07	3.6	6.0
Polyelectrolyte dose (kg/tonne)	4.5	2.4	8.5	2.1	1.5	2.7
Cake sludge DS (%)	7.9	4.2	9.9	22.1	20.1	27.8
Centrate SS (mg/l)	1003	610	1800	1068	200	5700
Solids recovery (%)	89.1	76.3	94.0	98.6	96.8	99.5

2.8 Rotoplug Concentrator

2.8.1 Introduction

The Rotoplug concentrator (Plate 11) is a machine which was originally designed to dewater sewage sludge in two stages without the aid of chemical conditioners. Most of the development work was carried out after 1958 and there were a number of units installed during the early 1960s⁸⁵⁻⁸⁸. Although many small-scale experiments were carried out with sludge from many parts of the UK the process was never widely adopted, mainly because of the low amount of solid matter which was retained in the cake. The machine was later modified to enable it to operate in conjunction with chemical conditioners but, by the late 1970s, few of the water authorities were operating the process.

2.8.2 Operation

Sludge is introduced into rotating cells, and the liquid together with fine SS drains through a nylon mesh fabric which has about 25 apertures/mm².

The cells are usually 360 mm wide, 920 mm dia., and can rotate at a variable speed, often less than 3 rev/min. The rotating action of the cells causes the sludge retained within to form a cylindrical plug approximately 150 mm in diameter, which is dewatered partly by its own weight and partly by the rolling action. As the rolling plug consolidates and grows in size, the end portion overflows the annular side and is cut away continuously, dropping into the second dewatering stage, compression.

The compression filter consists of a drainage wheel, which has a stainless-steel wedge-wire screen in the form of a wave at the periphery. Two pressure rollers of basically square cross-section match the wave formation of the drainage wheel. The thickened sludge from the rotating cells falls onto the drainage wheel and the rollers squeeze out surplus liquid. This then passes through the wheel and is returned to the inlet works. The dewatered cake is removed from the wheel by a doctor blade and can be tipped. A four-plug unit is shown in Fig. 25.

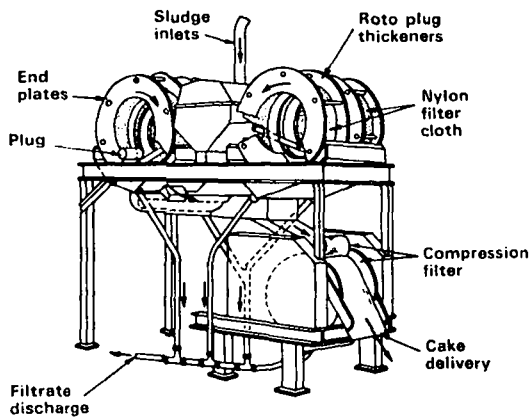

Fig. 25. Diagrammatic arrangement of a 4-plug sludge concentrator.

One of the suggested advantages of the unit was that it would operate with sludge which had not been chemically conditioned. However, the sludge cake was not always satisfactory and various units in the UK were modified to accept pulped paper which increased the bulk of the sludge and resulted in a greater degree of retention of solid matter in the cake. Some machines were modified ("the Flocomiser") to operate with chemical conditioners.

2.8.3 Performance

Before the introduction to the process of chemical conditioners, fine suspended solid matter passed through the fine nylon mesh of the rotating

cell so that the retention of solid matter was often as low as 50% and the filtrate often contained 20 000 mg/l SS. The final cake contained only 12–18% DS. The “fines” in the filtrate resulted in a progressive build-up of solid matter in the works, causing a further restriction in the efficiency of the machines. At most works the filtrate was not returned direct to the works’ inlet but through an intermediate settlement stage to reduce the amount of solid matter which was then returned to the primary sedimentation tanks. Following the modification to allow use of chemical conditioners, the retention of suspended solids increased to about 85% and the filtrate was returned direct to the work’s inlet. The quality of the cake improved and contained 16–20% DS which would dry further when tipped, although the consistency was often similar to blancmange.

It was found generally that the unit would deal fairly satisfactorily with raw primary sludge but that increasing the amount of secondary sludge progressively reduced the performance of the plant in terms of the amount of solid retained in the cake and the dryness of the cake.

3. Thermal Drying

3.1 Introduction

When sewage sludge is dewatered, either by mechanical methods such as a filter press or on a drying bed, the moisture content of the product can be in the range 50–80%. Thermal drying, using either a rotary-kiln drier or an Atritor-drier, is a method of further dewatering sludge cake by heating in order to obtain a granular product containing 85–90% DS. The low moisture content of the product allows it to be stored for a long period without deterioration, though the high cost of the process means that it is used only when the sludge is to be sold. A rotary-kiln drier was in use at Halifax until 1980 and an Atritor-drier is still operating satisfactorily at Dewsbury⁸⁹. Thermal driers were in use during the 1960s at Cheltenham, Bolton and Huyton, and before then the process had been used at Mogden, West Kent and West Herts sewage-treatment works.

When wet sludge is dried in hot air, there is evaporation from the surface, and moisture also migrates from the inside to the surface of the sludge. It is important that a balance is maintained between the evaporation from the surface and the migration of moisture to the surface, because when the evaporation rate is too high, thermal degradation occurs and odour problems are likely.

3.2 Rotary-kiln drier

The process is well established in the chemical and agricultural industries but had only rarely been used for drying sewage sludge. A typical rotary-kiln drier (Fig. 26) comprises:

- (a) a cylindrical steel kiln, typically 8 m long and 2 m in diameter, supported by bearings and mounted either horizontally or at a slight incline. A series of flights on the inside surface of the cylinder promotes a cascading motion as the sludge passes along the kiln;
- (b) an electric drive motor to rotate the kiln continuously;

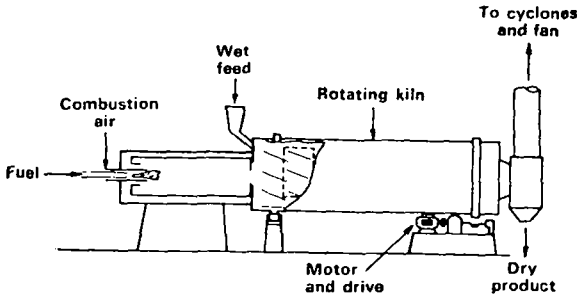

Fig. 26. Arrangement of rotary-kiln drier.

- (c) a combustion chamber to produce a continuous flow of hot air;
- (d) a cyclone and a scrubbing system to remove moisture and dust particles from the air which flows from the kiln, before it is vented to the atmosphere.
- (e) a fan to induce the flow of air through the kiln, cyclone and pipework.

3.2.1 Principal of operation

At Halifax, the dewatered cake from the filter presses was broken down in a contra-rotating breaker, and then carried in screw conveyors to the storage silo. The wet feed was introduced with the hot air obtained from the furnace into the top of the kiln and movement down the rotating steel drum was assisted by the cascading motion induced by the series of flights on the inner surface. The flights also constantly changed the surface, interrupted the flow of solid material and promoted turbulence in the air flow. Some of the dried sludge was recycled in proportions which allowed control of the heat requirement, and also a degree of uniformity of particle size which assisted the drying process. The temperature of the air at the entrance to the kiln varied between 300°C and 800°C and at the outlet it was about 100°C. At the bottom of the kiln the dried granular product fell into a receiving hopper, and the moisture-laden air passed to the cyclone and scrubber system and thence to atmosphere through a stack.

3.3 Atritor-drier

The Atritor (Fig. 27) (Plate 12) evolved from a machine used about 50 years ago for drying and pulverizing coal before direct feed to boilers. Basically the plant comprises:

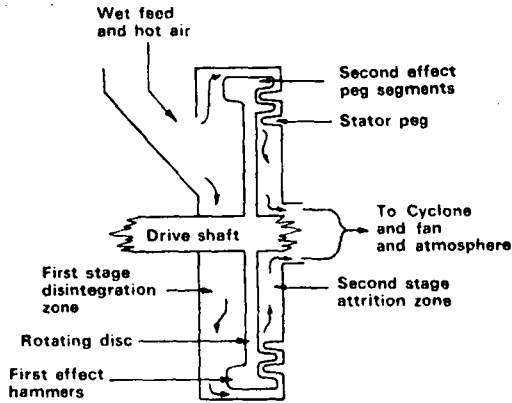

Fig. 27. Simplified diagram of Atritor drier.

- (a) An Atritor-drier-pulverizer in which sludge cake is disintegrated by rotating first-effect hammers, and then, in a second stage, pulverized by attrition between rotating second-effect peg segments and static pegs on the casing in a highly turbulent, hot-air flow. The large machine at Dewsbury⁸⁹ has an external diameter across the rotor of about 3 m, the rotor operates at 850 rev/min and the throughput of sludge cake is over 8 tonnes/h.
- (b) An electric drive motor.
- (c) A combustion chamber to produce a continuous flow of hot air.
- (d) A fan to induce the flow of air through the Atritor, cyclone and pipework.
- (e) A cyclone and scrubbing system to remove moisture and dust particles from the air which flows from the kiln, before it is vented to the atmosphere.

3.3.1 Principal of operation

The Atritor, as used in sludge treatment, is a self-contained two-stage pulverizer where disintegration forms the first stage and attrition the second stage. In the first compartment the sludge is disintegrated by the action of a number of peg segments on the rotating disk. As the sludge particles are reduced in size, they are carried by the hot air around the periphery of the rotating disk into the second compartment, the attrition zone. Here the particles are carried repeatedly in towards the centre and out again towards the periphery. This intense turbulence is created by a series of moving peg segments, mounted around the periphery of the rotating disk, which set up

eddies and vortices so that the particles rub together. Static pegs fixed to the casing prevent the gyration of the dust cloud and the rotor. As the particle size is reduced, the sludge is drawn out of the zone of turbulence towards the central drive shaft into ducts and thence to the cyclone collector. Hot air from a furnace is drawn through with the sludge, and as there is only a small amount of sludge in the attritor relative to the volume, and this is all in circulation, there is a very rapid transfer of heat. In the cyclone, the dried material is separated from the partially saturated transferred air.

The large-scale installation at Dewsbury⁸⁹, where press cake containing 60% DS is dried to a product containing about 85% DS, obtains hot air from a furnace which uses gas from a digester. Controls within the process automatically adjust the amount of hot air from the furnace between "high and low fire" according to the moisture content of the feed sludge. The outlet temperature is about 75°C and the range at the inlet is 320–550°C. Occasional checks are necessary to ensure a continuous supply of sludge and the removal of the dry product. Periodically, it is also necessary to remove any debris which may have accumulated. Maintenance is principally the periodic renewal of wearing plates and peg segments.

3.4 Nature of final product

The structure of the final product from a rotary kiln drier depends upon (a) the nature, (b) the size of the particles, and (c) the moisture content of the feed sludge. Normally, the dry product is granular and the size is determined by the size of the particles of the feed sludge, but it is important that there is sufficient moisture to encourage adhesion to the sludge surface for granules to form. Thus a relatively dry sludge feed may not form granules because the surface is not tacky enough for adhesion.

The Attritor-drier produces a stable, consistently fine-grained product, regardless of the condition of the feed sludge. The moisture content of the product should be 10–15% to prevent composting and fungal growth when the product is to be stored in bags. Material which is too dry can cause an excessive quantity of dust and this could lead to risks of fire and explosion as well as handling difficulties. In practice, operating adjustments are made to ensure that the final product is suitable for the purpose for which it is intended.

Appendix 1

Determination of Specific Resistance to Filtration

The relation between time (θ) and the volume of filtrate (V), after the initial time and flow of filtrate have been subtracted (see example) should be such that on plotting $\frac{\theta}{V}$ against V on linear graph paper a straight line can be drawn through the points. (If a straight-line relationship cannot be obtained, despite trying a number of different zero positions of θ and V , an average specific resistance cannot be calculated.) The slope of this line (b) is then directly proportional to the average specific resistance (r) according to the equation:

$$r = \frac{2A^2Pb}{\eta c}$$

where **A** is the filtration area

P is the filtration pressure

η is the viscosity of the filtrate (assumed to be the same as that of water)

c is the mass of dry suspended solids per unit volume of liquid in the sludge being filtered

b is the slope of the plot of $\frac{\theta}{V}$ against V .

If **A** is expressed in units of cm^2

P „ „ „ „ „ kPa

b „ „ „ „ „ s/ml^2

η „ „ „ „ „ poise

c „ „ „ „ „ g/ml

then the value of r may be calculated in units of m/kg (i.e. SI units) by using the following equation:

$$r = \frac{2A^2 \times P \times b}{\eta \times c} \times 10^5 \text{ m/kg}$$

A set of experimental data is given below. In this example the time (θ) and volume (V) data start when pressure was first applied. These values have been recalculated by discounting the volume of filtrate collected during the first 60 s. Thus from each time θ , 60 s is subtracted to give $\theta_n = \theta - 60$. Similarly, 13 ml (i.e. the volume of filtrate in the first 60 s) is subtracted from the corresponding filtrate volume V to give $V_n = V - 13$. From the tabulated

values of V_n and θ_n , the ratios $\frac{\theta_n}{V_n}$ are calculated. The ratios are plotted against the corresponding values of V_n , as shown in Fig. A.

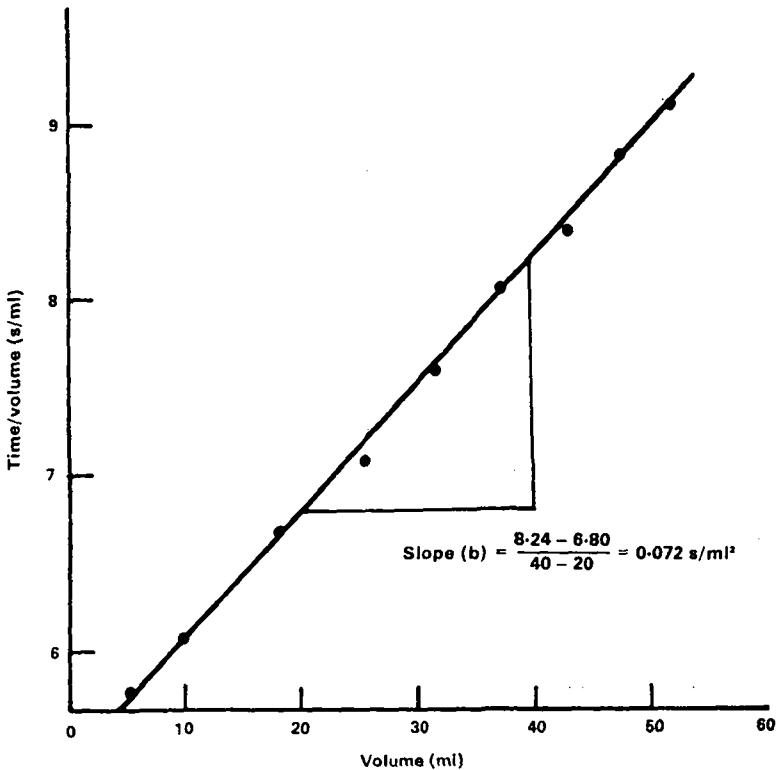

Fig. A. Plot of Buchner-funnel filtration data to obtain specific resistance to filtration

NUMERICAL EXAMPLE

Filtration Data

Experimental data		Derived data		
Time (s)	Filtrate (ml)	Time (s)	Filtrate (ml)	Ratio
θ	V	θ_n	V_n	θ_n/V_n
0	0			
30	7.2			
60	13.0	0	0	
90	18.2	30	5.2	6.77
120	22.9	60	9.9	6.06
180	31.0	120	18.0	6.67
240	38.4	180	25.4	7.09
300	44.6	240	31.6	7.59
360	50.3	300	37.3	8.04
420	56.1	360	43.1	8.35
480	60.7	420	47.7	8.81

Other Data

Total solids content of sludge = 3.56%

Total solids content of filtrate = 0.35%

∴ Suspended solids (by difference) = 3.21%

$$\therefore c = \frac{SS}{100-SS} = \frac{3.21}{100-3.21} = 0.0332 \text{ g/ml}$$

Temperature of sludge = 20.4°C

Pressure of filtration = 369 mm of mercury vacuum (= 49 kPa)

Area of filtration = 38.5 cm²

The slope of the line (b) = 0.072 s/ml²

Then with $2A^2 = 2964$

$$P = 49$$

$$b = 0.072$$

$$\eta = 0.01$$

$$c = 0.0332$$

$$r = \frac{2964 \times 49 \times 0.072}{0.01 \times 0.0332} \times 10^5 \text{ m/kg}$$

$$= \underline{\underline{3.15 \times 10^{12} \text{ m/kg}}}$$

Appendix 2

Theory of Coagulation and Flocculation

Introduction

The difficulty in dewatering unconditioned sewage sludges by filtration can be attributed largely to the presence of extremely fine solids. In order to permit rapid filtration it is necessary to bring about the aggregation of the fine solids by the process of coagulation or flocculation. The terms 'coagulation' and 'flocculation' are often used interchangeably¹⁰ and there are no universally-agreed definitions to distinguish clearly between them. However, for the purposes of this manual, *coagulation* is defined as the aggregation of particles using inorganic chemicals and *flocculation* is defined as the aggregation of particles by high-molecular-weight organic polyelectrolytes. These definitions accord with those of La Mer⁹⁰.

Coagulation with Inorganic Chemicals

The stability of colloids in sewage sludges can be attributed to two physico-chemical phenomena:

- (a) Electrical repulsion between particles carrying like-charges (usually negative charges in the case of sewage sludges) resulting in a kinetic barrier to aggregation.
- (b) Steric effects, such as those due to adsorption of macromolecules and to hydration, resulting in a thermodynamic barrier to aggregation.

The events which take place on the addition to sludge of a hydrolyzable electrolyte, such as an aluminium or iron salt, are complex and not fully understood. Stumm and O'Melia⁹¹ considered the time-dependent coagulation process to include six changes occurring sequentially and/or simultaneously:

- (i) Hydrolysis of the multivalent ion yielding highly (positively) charged inorganic polymeric ions which neutralize the charges on the sludge particles and reduce electrical repulsion;
- (ii) Adsorption of the hydrolysis products onto the solids causing destabilization;

- (iii) Aggregation of the destabilized particles by Van der Waal's forces;
- (iv) Aggregation of the destabilized particles by interparticle bridging;
- (v) 'Ageing' of the coagula, resulting in changes in the structure of the metal hydroxide linkages;
- (vi) Precipitation of the metal hydroxide leading to enmeshment of the fine solids in the hydroxide precipitate ('sweep' coagulation).

Addition of coagulants, such as aluminium chlorohydrate, represents an addition of highly-charged ions which are subject to further hydrolytic processes. Overall, the reaction may be written:

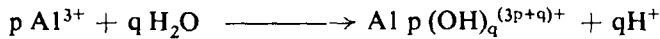

Whilst a complete description of the molecular nature of the coagulant is not yet possible, recent studies⁹⁰ indicate an average molecular weight of 1750 ± 500 .

Theory of Flocculation with Cationic Polyelectrolytes

It is generally accepted that the aggregation of fine particles in sludge brought about by flocculation with cationic polyelectrolytes is attributable to two mechanisms:

- (a) *Charge neutralization*. Neutralization of the negative electrical charges of the sludge particles by the positive charges of the polyelectrolyte molecules, leading to a reduction of the electrostatic repulsion between particles and their aggregation under the influence of Van der Waal's forces. Maximum flocculation occurs when the zeta potential of the particles is zero, i.e. complete neutralization.
- (b) *Polymer bridging*, i.e. formation of polymer bridges between particles. This mechanism depends on the ability of the long polymer molecule to attach itself by adsorption onto two or more sludge particles at the same time, thus drawing them together as a floc. The mechanism is not dependent on charge neutralization or electrostatic attraction as is evidenced by the ability of non-ionic polymers to bring about flocculation under certain conditions. Flocs formed by particle bridging tend to have a higher resistance to shear than flocs formed by charge neutralization.

The relative importance of the two mechanisms of flocculation (charge neutralization and polymer bridging) in particular cases depends on a number of factors, but particularly on the molecular weight and charge

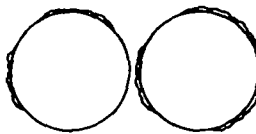
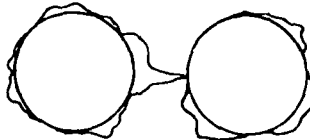
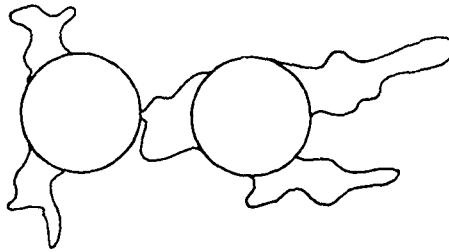
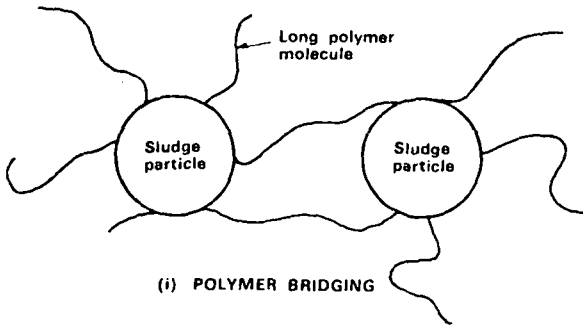

Fig. B. Possible mechanisms of flocculation by organic polyelectrolytes

density of the polyelectrolyte being used. The bridging mechanism may predominate when the polyelectrolyte has a high molecular weight and relatively low charge density. In this case, the configuration of the molecules tends to be 'stretched out' rather than 'looped'. In a suspension with a low electrolyte concentration, flocculation might then be brought about by the attachment of relatively few segments of a single polymer molecule to several particles. The mechanism is shown diagrammatically in Fig. B(i).

Alternatively, when a polyelectrolyte has a high molecular weight and a high charge density (or is in a highly-ionized solution), it will tend to assume a looped configuration on the surface of sludge particles. In this case, collision between particles will bring about aggregation of a looped polymer segment, or one particle can attach itself to an available site on another particle (Fig. B(ii)).

For successful aggregation by a bridging mechanism, it is essential that the extension of the adsorbed polymer molecule is greater than the interaction distance of repulsion forces and also that adsorption sites are available.

When charge neutralization is the predominant mechanism, the polymer molecules become attached to the oppositely-charged surfaces of the sludge particles and assume a configuration conforming fairly closely to the surface of the particle (Fig. B(iii)), i.e. not 'stretched out'. Destabilization and aggregation then occur as a result of Van der Waal's forces and possibly also electrostatic attraction between oppositely-charged sites. There may also be a slight degree of bridging.

Alternatively, when the polymer molecule is bound closely to the surface of the particles, the aggregation process may rely entirely on electrostatic attraction between oppositely-charged sites (Fig. B(iv)).

The last two cases generally apply where the polyelectrolyte is of relatively low molecular weight and with a large charge density. However, it should be emphasized that polyelectrolytes with both low molecular weights and low charge densities may also be quite effective as flocculants.

The effectiveness or otherwise of a given polyelectrolyte depends on many factors such as polymer type, particle size and concentration, the pH value and ionic strength of the liquid phase of the sludge. Generally it is found that high-molecular-weight polyelectrolytes work in dilute sludges and also where the sludge is thick and high floc strength is required. Low-molecular-weight polyelectrolytes are more effective with thick sludges than with thin sludges.

Appendix 3

Theory of Filtration

There have been many theoretical studies on the passage of liquids through filter media and the behaviour of solids under applied pressure, but it is debatable whether these are capable of use for accurate prediction of the practical results from filter-press installations. However, established theory is of great assistance in consideration of the practical difficulties which may be encountered.

Various equations relate the rate of flow with the total pressure difference across the cake and filter cloth, the viscosity, particle characteristics and voidage, and the flow resistance through the cake and cloth.

Normal methods of investigation of the filtrability of a sludge are the Buchner funnel test or capillary suction time (see Section 1.2). These tests do not reproduce the conditions occurring in a filter press since most press installations are designed with a fixed cake thickness and filtration occurs under two successive conditions, i.e. a period of virtually constant flow as the pressure differential is increasing, and subsequently a period of virtually constant pressure differential with decreasing flow.

A theoretical equation was developed by Jones⁹², but made the assumption that the rate of filtrate removal complied with that occurring in a Buchner-funnel filtration. The pressure filtration of a very compressible material, such as conditioned sewage sludge in restricted chamber thickness where compression will occur when the cake formation builds up from both filtration surfaces of the chamber, makes this assumption inappropriate, and work reported earlier³ has endorsed this fact.

The Kozeny equation demonstrates the effect on resistance to filtrate flow resulting from voidage and particle shape and size. Low voidage results in high specific resistance, and small changes in voidage result in considerable change in specific resistance. The resistance varies inversely with the square of particle diameter, i.e. smaller particles increase the specific resistance.

Variation of particle size in a given cake will result in smaller particles filling the voidage between larger particles, again increasing the resistance.

The compressibility coefficient (S), defined by the relationship $r = r_0 P^S$ is an indication of the degree of deformation of sludge flocs under pressure. S is the slope of the line given by plotting the log of specific resistance to filtration (r) against the log of the filtration pressure difference (P). Hence by measuring the specific resistance to filtration at different pressures the cake compressibility can be calculated, as illustrated in Fig. C.

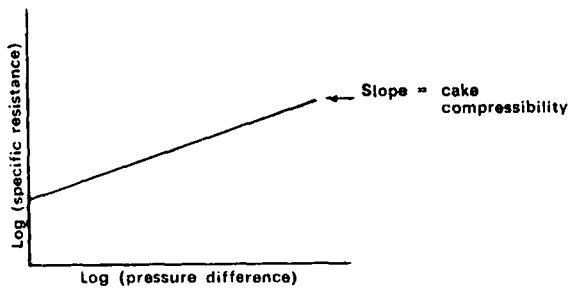

Fig. C. Graphical method for determination of cake compressibility

Results⁴⁵ have shown that the compressibility coefficient of unsheared conditioned sludge is far higher than that of the original sludge, i.e. the conditioned flocs are weaker than the unconditioned particles. Typical results for compressibility coefficients for sewage sludges are usually in the range 0.6-1.2, being higher in conditioned sludges with minimal shear.

Full descriptions of theoretical derivations for filtration theory have been reported⁹³⁻⁹⁵. The integrated form of the basic filtration equation for incompressible cake is:

$$\frac{\theta}{v} = \frac{(\eta \cdot r^* \cdot C^*) v}{2P_T} + \frac{\eta \cdot R_m}{P_T} \dots \dots \dots (1)$$

which assumes that P_T , η , r^* , C^* and R_m are all constant.

Where:

- θ = time (s)
- v = volume of filtrate obtained from unit area of filtration surface (cm³/cm²)
- η = viscosity of filtrate (poise)

r^* = true specific resistance (resistance of cake having unit mass of dry suspended solids per unit area of filtration surface (cm/g))

C^* = mass of dry suspended solids deposited on press cake per unit volume of filtrate derived (g/cm³)

P_T = difference in pressure across cake and filter medium (= $P_c + P_m$) (dynes/cm²).

R_m = resistance of flow of filtrate by filter medium (cm⁻¹).

$$v = \frac{V}{A}$$

where:

V = volume of filtrate derived with filtration area A (cm³)

A = filtration area (cm²)

Substituting in Equation 1 :

$$\frac{\theta}{V} = \left[\frac{\eta \cdot r^* \cdot C^*}{2A^2 P_T} \right] V + \frac{\eta \cdot R_m}{A \cdot P_T} \dots\dots\dots (2)$$

The line derived from a plot of θ/V against V has a slope of the term in brackets, and this is used in the method of determination of the specific resistance to filtration⁹⁶.

For compressible materials such as conditioned sewage sludges, the particles will be compressed by the applied forces, those closest to the filter cloth at the surface of cake deforming to the greatest extent. The compression reduces the voidage in the cake and hence increases its specific resistance, this being greatest where the deformation is greatest and in turn leads to further compression. Hence the solids content of the cake should progressively increase through the cake towards the filter medium, and Gale⁹³ has demonstrated this to be the case.

Assuming the resistance to flow of the filter medium (R_m) to be negligible compared with the resistance from the cake (R_c), the differential equation, derived for filtration of compressible cake is:

$$\frac{dv}{d\theta} = \frac{P_T \cdot 1}{\eta \bar{r}^* C^* V} \dots\dots\dots (3)$$

Where \bar{r}^* = average value of r^* for a compressible cake (cm/g).

As C^* is related to the solids concentrations of the cake and the feed sludge, it may be considered constant for a specific sludge under a particular filtration pressure. If the total pressure differential (P_T) is constant, \bar{r}^* can be regarded as constant, and Equation 3 integrates to:

$$v^2 = \frac{2P_T}{\eta} \cdot \frac{1}{\bar{r}^* \cdot C^*} \theta \dots\dots\dots (4)$$

which on substitution for $v = \frac{V}{A}$

$$\text{becomes } \frac{\theta}{v} = \frac{(\eta \cdot \bar{r}^* \cdot C^*)}{2P_T A^2} V \dots\dots\dots (5)$$

Knowing P_T , and C^* , then \bar{r}^* may be determined from the slope of the line obtained from a plot of θ against v .

In summary, the theory predicts that the solids content is highest adjacent to the filter medium and decreases through its depth, and this has been confirmed in practice. It is reasonable therefore to assume that the theoretical mechanisms postulated for compressible solids are relevant to sewage sludge, but only under certain assumed conditions, i.e. that the pressure drop through the cake, the average specific resistance (\bar{r}^*) and average cake composition are all constant. The mass of dry solids deposited on the press cake per unit volume of filtrate (C^*) is a function of the feed sludge and cake dry solids contents.

In laboratory determinations it is more usual to determine \bar{r} , the apparent resistance to filtration, rather than r^* . \bar{r} is calculated in a similar manner to that described above except that, instead of C^* , C_1 is used. C_1 is the weight of dry suspended solids associated with unit volume of liquid in the sludge.

Application of theory to practical situations must be exercised with caution since the assumed conditions in formulation of the theory may be at variance with the practical circumstances; however, the theory acts as a basis for the consideration of practical problems.

Concept of Degree of Completion⁴⁷

This concept assumes that the cake dry solids content close to the edge of the press chamber is the optimum for the whole cake if the pressing had been continued (100% completion). This is not strictly the case because the solids content at the edge of the cake increases slightly after its initial formation. The percentage completion has been defined as $a/b \times 100$, where a is the total mass of SS in the volume of sludge used, less the total mass of SS in

the filtrate, and b is the mass of SS which would have occupied the volume of the chamber had the cake been uniformly the same dry solids content of the cake at the edge of the chamber. The simplified equation for the degree of completion is:

$$\% \text{ completion} = \frac{V_s \cdot w_s}{V_c \cdot w_c \cdot \rho_c} \times 100 \dots\dots\dots (6)$$

- where V_s = volume of sludge used
- w_s = fractional DS content of the sludge
- V_c = net volume of chamber
- w_c = fractional solids content of cake at the edge of the chamber
- ρ_c = density of cake at the edge of chamber.

An alternative method of calculating the degree of completion is based upon the concept that a filter pressing is 100% complete when the filtration rate approaches zero. The volume of filtrate required if 100% completion is to be achieved is determined by extrapolation of the linear portion of the plot

of the rate of filtration ($\frac{dV}{dt}$) against the total volume of filtrate (v); when

$\frac{dV}{dt}$ is zero the volume of filtrate corresponds to 100% completion.

It is assumed that during the initial part of pressure filtration the sludge entering the chamber is the same dry solids content of the feed sludge and, as the process proceeds, the low dry solids content cakes formed on the filtration surfaces on each side of the chamber progressively build up and meet, virtually filling the chamber. Entry of further sludge into the chamber can then occur only by displacement of the wet cake already formed, which results in the harder cakes at the edges of the chamber, the centre still being relatively wet. Compression of the wet cake, thus allowing more solids to enter the chamber, results in further separation of liquid from the solids particles. However, the latter may occur to varying degrees resulting in incomplete formation of cake and, because the movement of solids is retarded, considerable thickening of the sludge in the feed holes can occur ("coring").

'Jones' Equation for Prediction of Pressing Period

$$T = \frac{0.321 \cdot \eta \cdot d^2 \cdot (w_c - w_s)^2}{P \cdot w_s \cdot (1 - w_s)} \rho_s^2 \cdot f \text{ hours} \dots\dots\dots (7)$$

where

- T = pressing period (h)
 d = chamber thickness (inches)
 η = filtrate viscosity (centipoise)
 ρ = density of cake
 w_s and w_c = fractional solids contents of feed sludges and cake, respectively
 P = pressure (lb/in²)
 \bar{r} = apparent specific resistance to filtration of the sludge ($\times 10^7$ s²/g) at press operating pressure (100 lb/in²)
 0.321 = a constant derived from the units utilized.

Results by Baskerville *et al*⁴⁷ did not agree with the pressing periods predicted by the Jones formula, but did confirm within reason that the pressing period is proportional to the specific resistance to filtration of the sludge.

Effect of Solids Content of Feed Sludge on Pressing Period

Jones⁹⁵ predicted that the effect of feed sludge solids content on the pressing period is:

$$T \frac{(w_c - w_s)^2}{w_s (1 - w_s)} \dots \dots \dots (8)$$

Hence for a given cake quality the effect of change in feed sludge solids can be assessed. Practical assessments⁴⁷ have demonstrated reasonable agreement with Equation 8 and that it is useful for obtaining an indication of the effect of a change in the feed sludge solids concentration.

Appendix 4

A. Clarification: the Sigma theory

The Sigma theory is based on Stokes' law of particle sedimentation and makes certain assumptions of this law.

The general equation is:

$$Q = \Sigma Vg$$

where:

Q is the feed rate

Vg is the terminal settling velocity of the particle under gravity, and

$$\Sigma = \frac{V}{S} \times \frac{rw^2}{g}$$

where: V is the volume of liquid in the bowl of the centrifuge

S is the effective settling distance

r the outer radius of the liquid in the bowl

w the angular velocity

g the acceleration due to gravity.

This equation can be simplified to:

$$\Sigma = AG$$

Where: A is the internal settling area of the centrifuge

G is the 'G' number or the ratio of the gravitational field developed by the centrifuge to that of the earth.

The Σ factor can now be visualized as the area of a conventional settling system equivalent to that of the centrifuge. Theoretically Σ is more complex when derived by pure mathematics, but the above simplified expression is sufficient for most practical purposes.

The scale-up problem envisages two machines: a small machine for which results have been obtained at flow rates much lower than that of the machine to be installed, and a hypothetical machine which is to be sized for the design flow rate.

The Sigma theory postulates that for the same sludge at the same operating conditions in similar machines the terminal velocity, V_g , will be constant and that the following equation is valid:

$$\left(\frac{Q}{\Sigma}\right)_1 = \left(\frac{Q}{\Sigma}\right)_2$$

where 1 and 2 refer to the two machines. Thus the required Σ factor for the full-scale machine can be calculated, and the designer can choose the full-size machine.

This method can be used only with care and experience because of the limited validity of Stokes' law when applied to a concentrated suspension of compressible flocculant particles settling inside a centrifuge. The deficiencies have been summarized⁷⁹ as follows:

- (i) The particles normally settle under hindered settling conditions and not in a laminar flow regime assumed by Stokes' law.
- (ii) The theory ignores the compressibility of the sludge and the volume it occupies.
- (iii) The particles never attain the assumed terminal velocity since they are constantly being accelerated.
- (iv) The assumption that the rotational speed of the bowl is the same as the particles, is not always true.
- (v) The effects of shear will reduce the size of the particles and thus reduce their velocity.

Despite these limitations, the theory has been found to be useful provided that the two machines do not differ greatly in relative geometry. It is equally valid for most centrifuges where the principle method of separation is by sedimentation.

Although a different Sigma derivation is required, it is applicable only where the performance of the machine is limited by clarification needs. Where the performance is limited by a need for a drier cake, the Beta theory is applied.

B. Clarification: the Beta theory

The Beta theory⁷⁹, which is used in a similar manner to the Sigma theory postulates that for the same sludge and similar machines,

$$\left(\frac{Q_s}{\beta}\right)_1 = \gamma = \left(\frac{Q_s}{\beta}\right)_2$$

- where Q_s = solids throughput of the machine
 β = $\Delta W.SN\pi DP$
 ΔW = differential speed between the bowl and the scroll
 S = distance between the flights of the scroll
 N = number of leads on the scroll
 D = diameter of the cylinder
 P = depth of the pond

The subscripts refer to each machine.

This theory has been developed only for decanting centrifuges. It also has limitations in that it assumes that the density of the sludge does not differ between the two machines and that slippage is negligible. The designer must also decide whether the operation is limited by the clarification or thickening function.

Appendix 5

A. Derivation of 'G' force during centrifugation

(i) *Symbols and definitions:*

- D = bowl diameter (cm)
F = centrifugal force as a factor of the terrestrial gravitational force = 'G' force
 f_c = absolute centrifuge force (dynes)
 f_g = absolute gravitational force (dynes)
g = terrestrial gravitational constant (cm/s²) ≈ 981
m = mass of a particle (g)
N = rotational speed (rev/min)
r = radius (cm)
w = angular velocity (radians/s)

(ii) *Equation for f_c*

Consider a particle (mass m) rotating in a plane circle (radius r) at a constant angular velocity of w. Then

$$f_c = mw^2r$$

(iii) *Equation for f_g*

For the same particle

$$f_g = mg$$

(iv) *Equation for F (cgs units)*

$$\begin{aligned} \text{By definition } F &= f_c/f_g \\ &= \frac{mw^2r}{mg} \\ &= \frac{w^2r}{g} \end{aligned}$$

(v) *Conversion to practical units*(i) Where a circle has a radius of r cm and diameter D cm, $r = \frac{D}{2}$ (ii) In 1 s the particle describes $\frac{N}{60}$ revolutionsBut 1 revolution is equivalent to 2π radians.

$$\therefore w = \frac{N}{60} \times 2\pi = \frac{2\pi N}{60}$$

(vi) *Equation for F (practical units)*

$$\text{From (iv) } F = \frac{w^2 r}{g}$$

substituting from (v)

$$F = \frac{(2\pi N)^2}{(60)^2} \cdot \frac{D}{2g}$$

$$= \frac{(2\pi)^2}{(60)^2} \cdot \frac{N^2 D}{2g}$$

If $g = 981$,

$$F = \frac{5.6 N^2 D}{10^6} \quad \left(\text{or } F = \frac{5.6 N^2 D}{10^7} \right)$$

(Where the radius is)
in mm

B. Mechanism of scrolling

Any prediction of scrolling performance, which requires an understanding of the mechanism of scrolling, needs to be used in conjunction with the Sigma theory when designing a full-scale plant. Fig. D(i) shows a side view of a particle resting against a scroll flight on the bowl, and shows the weight of the particle resolved both parallel to and normal to the beach.

Fig. D(ii) shows a plan view of the previous figure and shows the four forces parallel to the surface of the beach, acting to keep the particle in equilibrium. The first is a reaction normal to the scroll, the second is due to the frictional forces of the scroll, the third is the weight of the particle resolved down the beach and the fourth is the frictional force produced by the beach which reacts against the resultant of the other three.

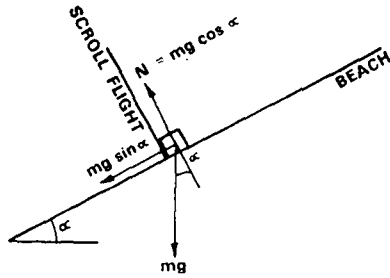

Fig. D(i). Side view of a particle resting against a scroll flight on bowl, and weight of particle resolved both parallel to and normal to beach

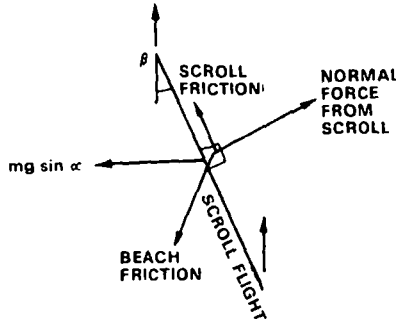

Fig. D(ii). Plan view of Fig. D(i) showing four forces parallel to surface of beach, acting to keep particle in equilibrium

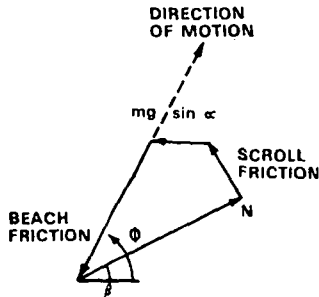

Fig. D(iii). Force diagram

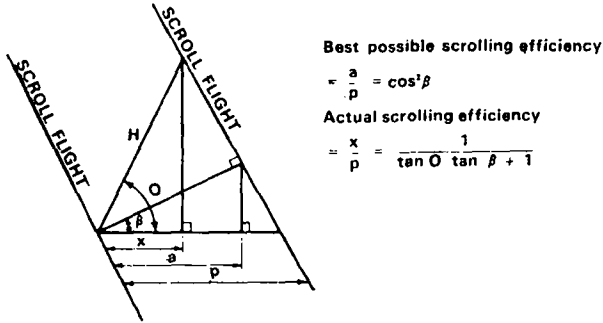

Fig. D(iv). Method of calculating scrolling efficiency

Fig. D(iii) shows the force diagram. From this it can be seen that if the scroll friction is increased, or the particle weight is increased, or $mg \sin \alpha$ is increased by increasing the beach angle, there will be a point when the angle to the axis which the particle travels will become greater than 90° , with the result that scrolling up the beach will cease. Thus, to improve scrolling efficiency, the scroll flights should be smooth and the beach either grooved or ribbed along the direction of travel. Additionally, the beach angle and scroll pitch should be kept as small as possible without causing bridging between flights and plugging between beach and scroll hub.

When reviewing the previous three figures one needs to take into account that the effective weight of the particle will increase as it leaves the pond owing to the loss of buoyancy caused by the water; thus a deeper pond assists the removal of those sludges that are more difficult to scroll.

The scrolling efficiency can be calculated from Fig. D(iv).

C. Derivation of expression for solids recovery

Rates of recovery are calculated by a method which is similar for all forms of dewatering equipment. The expression can be calculated as follows on a mass balance basis:

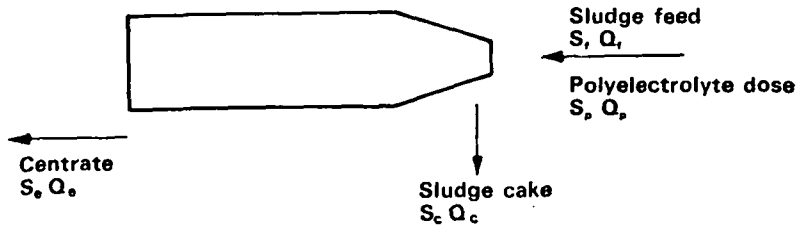

Where:

- S_f = Dry solids content of feed sludge (kg/kg)
- Q_f = Wet sludge feed rate (kg/h)
- S_p = Strength of polyelectrolyte solution (kg/kg)
- Q_p = Dose rate of polyelectrolyte solution (kg of solution/h).
- S_c = Dry solids content of sludge cake (kg/kg)
- Q_c = Rate of wet cake discharge (kg/h)
- S_e = Dry solids content of centrate (kg/kg)
- Q_e = Rate of centrate discharge (kg/h)
- R = % solids recovery

Let
$$\frac{S_f Q_f}{Q_f + Q_p} = S_t \dots\dots\dots (1)$$

Let $Q_f + Q_p = Q_e + Q_c = Q_t \dots\dots\dots (2)$

By mass balance

$$S_t Q_t = S_e Q_e + S_c Q_c$$

From Equation (2)

$$S_t Q_t = S_e (Q_t - Q_c) + S_c Q_c$$

$$S_t Q_t - S_e Q_t = S_c Q_c - S_e Q_c$$

hence:

$$Q_t (S_t - S_e) = Q_c (S_c - S_e)$$

or
$$\frac{Q_c}{Q_t} = \frac{S_t - S_e}{S_c - S_e} \dots\dots\dots (3)$$

$$\% \text{ solids recovery (R)} = \frac{S_c Q_c}{S_f Q_f} \times 100$$

From Equations 1 and 2, $S_t Q_t = S_f Q_f$

hence R =
$$\frac{S_c Q_c}{S_t Q_t} \times 100 \dots\dots\dots (4)$$

Substituting from Equation 3

$$R = \frac{S_c (S_t - S_e)}{S_t (S_c - S_e)} \times 100 \dots\dots\dots (5)$$

As the mass of solids entering the machine from the polyelectrolyte solution is low compared to the mass of solids entering the sludge, the following relationship can be used as an approximation for rapid tests calculations:

$$R = \frac{(S_t - S_e)}{S_t} \times 100$$

References

1. MINISTRY OF TECHNOLOGY. Sludge dewatering on drying beds. *Notes on Water Pollution No. 35*, HMSO, 1966.
2. BASKERVILLE, R. C., BRUCE, A. M., and DAY, M. C. Laboratory techniques for predicting and evaluating the performance of a filter-belt press. *Filtrn & Separn*, 1978, **5**, 445.
3. BASKERVILLE, R. C., and GALE, R. S. A simple automatic instrument for determining the filtrability of sludges. *Wat.Pollut.Control*, 1968, **67**, (2), 233.
4. PURCHAS, D. B. Solid/liquid separation equipment scale-up. Chapter 3, Uplands Press, 178.
5. COMMISSION OF THE EUROPEAN COMMUNITIES. COST Project 68. *Sewage Sludge Processing*. Final Report of the Management Committee. Brussels, November 1975.
6. GALE, R. S. Some aspects of the mechanical dewatering of sewage sludge. *Filtrn & Separn*, 1968, **5**, 133.
7. BASKERVILLE, R. C., KOMOREK, J. A., and GALE, R. S. Effect of operating variables on filter press performance. *Wat.Pollut.Control*, 1971, **70**, (4), 400.
8. GALE, R. S., and BASKERVILLE, R. C. Studies on the vacuum filtration of sewage sludge. *Wat.Pollut.Control*, 1970, **69**, (5), 514.
9. KAVANAGH, B. V. The dewatering of activated sludge: measurement of resistance to filtration and capillary suction time. *Wat.Pollut.Control*, 1980, **79**, (3), 388.
10. INSTITUTE OF WATER POLLUTION CONTROL. *Glossary of Terms used in Water Pollution Control*. Manuals of British Practice in Water Pollution Control, 1975.
11. MINISTRY OF HOUSING AND LOCAL GOVERNMENT. *Report of an Informal Working Party on the Treatment of Sewage Sludge*. HMSO, 1954.
12. BRADE, C. E. Personal communication.
13. HOLLYHEAD, G. Personal communication.
14. GILLING, I. Personal communication.
15. SWANWICK, K. H. Control of filter pressing at Sheffield. *Wat.Pollut.Control*, 1973, **72**, (1), 78.
16. STANBRIDGE, H. H. *The History of Sewage Treatment in Britain*. The Institute of Water Pollution Control, 1977.
17. LUMB, C. Heat treatment as an aid to sludge dewatering: ten years full-scale operation. *J.Proc.Inst.Sew.Purif.*, 1940, 15.
18. BROOKS, R. B. Heat treatment of activated sludge. *Wat.Pollut.Control*, 1968, **67**, (5), 592.

19. BROOKS, R. B. Heat treatment of sewage sludge. *Wat.Pollut.Control*, 1970, **69**, (1), 92.
20. BROOKS, R. B. Heat treatment of sewage sludge. *Wat.Pollut.Control*, 1970, **69**, (2), 221.
21. FISHER, W. J., and SWANWICK, J. D. High-temperature treatment of sewage sludge. *Wat.Pollut.Control*, 1971, **70**, (4), 355.
22. HIRST, G., MULHALL, K., and HEMMING, M. The sludge heat treatment and pressing plant at Pudsey: design and initial operating experiences. *Wat.Pollut.Control*, 1972, **71**, (5), 455.
23. McDONALD, J., PAGE, V., and BELLIS, R. The-wet air oxidation of sludge at Hockford sewage works. *Effl.Wat.Treat.J.*, Jan. 1974, 13.
24. HUDSON, J. A., and PHILLIPS, MRS. G. Developments in sewage treatment at Leeds. *Wat.Pollut.Control*, 1975, **74**, (5), 544.
25. WHITEHEAD, C., and SMITH, E. Sludge heat treatment: operation and management. *Wat.Pollut.Control*, 1976, **75**, (1), 31.
26. DEPARTMENT OF SCIENTIFIC AND INDUSTRIAL RESEARCH. *Water Pollution Research* 1962, Table 19, p.63.
27. SWANWICK, J. D., WHITE, K. J., and DAVIDSON, MARIAN F. Some recent investigations concerning the dewatering of sewage sludges. *J.Proc.Inst.Sew.Purif.*, 1962, (5), 394.
28. MINISTRY OF TECHNOLOGY. Sludge dewatering on drying beds. *Notes on Water Pollution*, No.35. December 1966.
29. SWANWICK, J. D., and BASKERVILLE, R. C. Sludge dewatering on drying beds. *J.Proc. Inst.Sew.Purif.*, 1966, (2), 167.
30. CASSIDY, J. E., and FOURACRE, A. G. Sludge treatment and disposal at Bournemouth. *Wat.Pollut.Control*, 1967, **66**, (5), 473.
31. VICK, E. G. Experimental work at the Northern Outfall Works of the London County Council, 1940-1946. *J.Proc.Inst.Sew.Purif.*, 1946, (2) 163.
32. BARRACLOUGH, D. H. Water pollution control in the Burgh of Motherwell and Wishaw. *Wat.Pollut.Control*, 1969, **68**, (1), 105.
33. SPARHAM, V. R., and WAIN, J. A. The development of the wire wedge bed and the techniques associated with it. *Wat.Pollut.Control*, 1967, **66**, (5), 483.
34. WRIGLEY, K. J. Kew sewage treatment works: operation and performance. *Wat. Pollut.Control*, 1967, **66**, (3), 263.
35. CUMBERLAND, F. Borough of Reigate: Earlswood sewage works. *J.Proc.Inst.Sew.Purif.*, 1950, (2), 90.
36. GUNN, A. S. The Coleshill pressure-filtration plant. *Wat.Pollut.Control*, 1978, **77**, (3), 307.
37. ROBERTS, P. F. Personal communication.
38. EDMONDSON, B. R., and BROOKS, D. R. Some tests on the membrane filter plate. *Wat. Pollut.Control*, 1978, **77**, (1), 117.
39. WHITE, M. D. J., and BASKERVILLE, R. C. Filter-cloth blinding. *Effl. Wat.Treat.J.*, 1974, **14**, 503.

40. HOLDING, J. C. Experimental work on digested sludge pressing. *Wat.Pollut.Control*, 1968, **67**, (5), 528.
41. STILLINGFLEET, J. V. Filter pressing on digested sludge with chemical conditioning. *J.Proc.Inst.Sew.Purif.*, 1958, (1), 41.
42. BRADE, C. E., and SAMBIDGE, N. E. W. The effect of surplus activated sludge in filter press performance. *Wat.Pollut.Control*, 1974, **73**, (2), 138.
43. WEBB, L. J. A study of conditioning sewage sludges with lime. *Wat.Pollut.Control*, 1974, **73**, (2), 192.
44. ASHMAN, P. S., and ROBERTS, P. F. Operating experiences with vacuum filtration at St. Helens: a solution to the problem. *Wat.Pollut.Control*, 1970, **69**, (6), 638.
45. GALE, R. S., BASKERVILLE, R. C., and SWANWICK, J. D. Investigations of pressure filtration of raw sewage sludge. *Wat.Pollut.Control*, 1967, (6), 553.
46. WHITE, J. D., and BASKERVILLE, R. C. Full-scale trials of polyelectrolytes for conditioning of sewage sludges for filter pressing. *Wat.Pollut.Control*, 1974, **73**, (5), 486.
47. BASKERVILLE, R. C., KOMEREK, J. A., and GALE, R. S. Effect of operating variables on filter press performance. *Wat.Pollut.Control*, 1971, **70**, (4), 400.
48. DEPARTMENT OF THE ENVIRONMENT. *Water Pollution Research*, 1970, 99.
49. EDMONDSON, J. H., and LUMB, C. Experimental work on the secondary sludge problem. *J.Proc.Inst.Sew.Purif.*, 1934, (1), 83.
50. MINISTRY OF TECHNOLOGY. *Water Pollution Research*, 1966, p. 102. *Water Pollution Research*, 1967, p. 124.
51. GILLING, I. Personal communication.
52. LEWIN, V H. Oxford sewage and pumping scheme. *J.Proc.Inst.Sew.Purif.*, 1955, (2), 112.
53. ASHMAN, P. S. Operating experiences of vacuum filtration at St. Helens. *Wat.Pollut. Control*, 1969, **68**, (1), 20.
54. SLEETH, R. E. Personal communication.
55. SLEETH, R. E. An assessment of polyelectrolytes for sludge conditioning at Worthing. *Wat.Pollut.Control*, 1970, **69**, (1), 31.
56. ELLIS, K. V. Dewatering of digested sludge by a Komline-Sanderson coil filter. *J.Proc. Inst.Sew.Purif.*, 1965, (4), 379.
57. BROCK, S., and McDONALD, P. Eccles water pollution control works. *Wat.Pollut. Control*, 1971, **70**, (3), 313.
58. CRAIB, D. C. The design, construction and operation of a small treatment works. *Wat.Pollut.Control*, 1972, **71**, (6), 654.
59. DICKENS, R. Personal communication.
60. SMITH, W. S. In discussion. *Wat.Pollut.Control*, 1970, **69**, (5), 537.
61. GALE, R. S. The calculation of theoretical yields of rotary vacuum filters. *Wat.Pollut. Control*, 1971, **70**, (1), 114.

62. LEWIN, V. H. Disposal of industrial and sewage sludges. *Effl. Wat. Treat. Manual*. 3rd Edn. Thunderbird Enterprises Ltd., London, 1966, 69.
63. BUTLER, B. E. Personal communication.
64. MILBURN, R., and JACKSON, H. H. BP 2855. August 1873.
65. Deputation appointed by the Town Council and Board of Police of Glasgow. *Report on methods of disposal of sewage adopted in various towns in England*. p. 39.
66. MANCHESTER RIVERS DEPARTMENT. Report for the year ended 29th March 1922.
67. WOOD, UK Pat. 222221.
68. MORGAN, E. H. 1934 — US Pat. 1958279.
69. GOODMAN, B. L. 1970 — US Pat. 3531404.
70. SCHOVER, D. S. 1970 — US Pat. 3601039.
71. HARLEYFORD HYDROSAND 1972 — UK Pat. 1415297.
72. KLEIN, 1966 — UK Pat. 1149091.
73. Project Report No. 4 DOE 'Sewage Sludge Dewatering by Filter Belt Press'.
74. Threshold Limit Values for 1978 — Guidance Note EH 15/78.
75. HUTTON, J. L. Sludge dewatering by the filter belt press process. Paper presented to 33rd Cebedeau int. conf., Liege, May, 1980.
76. HIRST, G. Personal communication.
77. HOWARTH, P. J. *Effl. Wat. Treat. J.*, 1973, 10, 617.
78. AMBLER, C. M. Evaluation of centrifuge performance. *Chem. Eng. Prog.*, 1952, 48, 150.
79. VESILIND, P. A. Scale-up of solid bowl centrifuge performance. *J. Environ. Eng. Div. ASCE*, 1974, 100, EE2, 479.
80. SCOTTISH DEVELOPMENT DEPARTMENT. *Report No. ARD 1*. Dewatering of sewage sludge by centrifuge.
81. ALBERTSON, O. E. and GUIDI, E. E. Centrifugation of waste sludges. *J. Wat. Pollut. Control Fed.*, 1969, 41, 607.
82. SIDWICK, J. M., BUTLER, B. E., and RUSCOMBE-KING, N. J. Sludge dewatering trials at Banbury. *Wat. Pollut. Control*, 1975, 74, (6), 675.
83. CLARK, E. Personal communication.
84. BETTESWORTH, T. R. Personal communication.
85. TRUESDALE, G., and BIRKBECK, A. Tests of a mechanical sludge dewatering plant. *J. Proc. Inst. Sew. Purif.*, 1963, (4), 307.
86. BERGER, O., and WARREN, A. The Rotoplug sludge concentrator: developments in design and operations: 1959-1965. *J. Proc. Inst. Sew. Purif.*, 1966, (4), 327.

87. SURIYADASA, R. Investigations on mechanical dewatering of digested sludge at Colchester. *J.Proc.Inst.Sew.Purif.*, 1966, (4), 337.
88. HAMILTON, D. Mechanical dewatering of mixed sludges at Andover. *Wat.Pollut. Control*, 1969, (2), 224.
89. CREE, C. N. L. Personal communication.
90. La MER, V. K., and HEALEY, T. W. *J.Phys.Chem.*, 1963, 67, 2417.
91. STUMM, W., and O'MELIA, C. R. Stoichiometry of coagulation. *J.Am.Wat.Wks.Ass.*, 1968, 60, (5). 514.
92. JONES, B. R. S. Vacuum sludge filtration. *Sew.and Ind.Wastes*, 1956, 28, 1103.
93. GALE, R. S. Filtration theory with special reference to sewage sludges. *Wat.Pollut. Control*, 1967, 66, (6), 622.
94. COAKLEY, P. Research on sewage sludge carried out in the Civil Engineering Department of University College, London, *J.Proc.Inst.Sew.Purif.*, 1955, (1), 59.
95. JONES, B. R. S. Sewage sludge filtration. Ph.D.Thesis, University of London, 1955.
96. SWANWICK, J. D., and DAVIDSON, M. F. Determination of specific resistance to filtration. *Wat.Waste Treat.J.*, 1961, 8, 386.

INDEX

Age of sludge	74, 86	Design of filter press	45
Agitator	62	Design of rotary-drum vacuum filter	58
Aluminium chlorohydrate	28, 39	Design of vacuum disk filter	66
Application, depth of	44	Determination of specific resistance to filtration	96
Application of centrifuge	78	Dewatering of sludge	37
Application of drying beds	42	Digested sludge, centrifuging of	89
Application of filter belt press	70	Dosage rates, polyelectrolyte	87
Application of filter press	52	Drainage, pressplate	47
Application of sludge	42	Drainage medium	63
Application of vacuum filter	57	Drainage zone	71
Area of beds	40	Dried sludge, removal of	43, 44
Assessment, methods of	13	Drives	82
Atritor dryer	93, 94	Drop-off	65
Automatic valve	60	Drum immersion	63
Band filter (filter belt press)	68	Dry solids content	44, 62, 85
Beach angle	81	Drying beds	38, 39, 40, 41
Beaker test	14	Eductor	29
Bed (drying) surface	42	Effect of pond depth on recovery	85
Belts	71, 75	Effect of sludge feed solids on recovery	86
Beta theory	110	Effect of solids content on pressing period	103
Bowl speed	81, 87	Elutriates, analysis of	24, 25, 26
Buchner funnel filtration	23, 97	Elutriation	24, 25, 26
Buildings	46	Factors affecting coagulant de- mand	31
Cake, compressibility of	104	Factors affecting operation	61
Cake discharge	59	Factors affecting performance	43
Cake handling and disposal	52	Fibres	51
Capillary suction time (CST)	18	Filter belt press (band filters)	68, 69, 70
Centrifuge	77	Filter cloths	49
Chemical conditioning	27, 62	Filter press	45
Chemical injection	67	Filtrate	65
Clarification: the Beta theory	110	Filtration, theory of	103
Clarification: the Sigma theory	109	Final compression zone	72
Cloth design	50	Floc strength	20
Cloth materials	50, 58	Floc zone	83
Cloth covered filter	58	Flocculation, theory of	99, 100
Coagulant demand, factors affect- ing	31	Floor, drying bed	41
Coagulation and flocculation, theory of	99	'G' force, derivation of	112
Coil filter	59	Gravity drainage tube test	16, 17
Compressibility coefficient	104	Heat-treatment process	33, 34
Concept of degree of completion	106	Heating and recovery	34
Condition of drainage medium	44	Initial compression zone	72
Condition of filtration medium	62	Initial dry solids content	44
Conditioning of sludge	53, 60, 67	Inlets, drying bed	40
Conditioning tanks	46	Jet wet dispenser	30
Conditioning, thermal	32, 33	Jones' equation	107
Continuous flow settlement	35	Lifting dried sludge	43
Control tests	63, 75, 80	Lifting machines	43
Copperas	27	Lime	27
Covers, drying bed	41		
Degree of completion	106		
Depth of application	44		
Derivation of 'G' force	112		
Design of centrifuge	80		
Design of drying beds	40		
Design of filter belt press	71		

Liquor, separated	44	Rotary-drum vacuum filter	56, 57
Loading	44	Rotary-kiln drier	92, 93
Maintenance of centrifuges	88	Rotoplug concentrator	89, 90
Maintenance of drying beds	43	Scroll	82
Maintenance of filter belt presses	76	Scrolling, mechanism of	113
Maintenance of filter presses	55	Separated liquor	42, 44
Maintenance of thermal conditioning plants	35	Settlement, continuous flow	35
Maintenance of vacuum filters	63	Side-bar press	45, 46
Mechanism of scrolling	113	Sigma theory	109
Mechanization of filter presses	49	Sludge age	74, 86
Media, drying bed	40	Sludge, application of	42
Membrane plate	48	Sludge bath	59
Methods of assessment	13	Sludge concentrator	89, 90
Mixing	32, 75	Sludge conditioning and mixing	53, 60
Nature of feed sludge	74, 84	Sludge dewatering	37
Nature of final product	95	Sludge feed zone	83
Nature of sludge	43, 62, 84	Sludge, nature of	43
Nozzle-bowl centrifuge	78, 79	Sludge storage	32, 46
Odour nuisance	35, 43	Sludge, type of	31
Operation of centrifuges	84	Solid-bowl scroll discharge centrifuge	79
Operation of drying beds	42	Solids recovery, derivation of expression	115
Operation of filter belt press	73, 74	Specific resistance to filtration (SRF)	22, 23, 96
Operation of filter press	53	Speed differential	83, 86, 87
Operation of heat-treatment process	34	Speed of disk rotation	68
Operation of Rotoplug concentrator	89	Speed of mixer	67
Operation of vacuum disk filter	67	Standard shear test	19, 20
Operation of vacuum filter	61	Surplus activated, centrifuging of	89
Overhead-beam press	46	Thermal conditioning	32, 33, 35
Performance of centrifuges	89	Thermal drying	92
Performance of drying beds	43	Theory, filtration	103
Performance of filter belt press	77	Theory of coagulation and drying	99
Performance of filter press	56	Top dressing	43
Performance of Rotoplug concentrator	90	Treatment, preliminary	34, 39
Performance of vacuum disk filter	68	Types of centrifuge	77
Performance of vacuum filter	64	Types of cloth	68
Period of storage	32	Types of filter-belt press	72
Peripheral speed of drum	63	Types of filter press	45
Polyelectrolytes	21, 28, 87	Types of sludge	31
Pond depth	80, 85	Types of vacuum filter	58
Position of chemical injection points	67	Typical polyelectrolyte dosage rates	87
Preliminary treatment of sludge	34, 39	Underdrains	41
Preparation of bed surface	42	Vacuum disk filter	66
Press feed pumps	46	Vacuum pump	60
Press plates	47, 48	Vacuum receiver	60
Pressing period	54	Visual observation by beaker test	14
Rate of feed and pressure	54	Walls of drying beds	41
Rate of sludge input	87	Wash-water pumps	60
Recovery, heating and	34	Weather conditions	44
Removal of dried sludge	42	Weave properties	51
Replenishment of top dressing	43	Withdrawal of separated liquor	42
		Zimpro process	33