

skat_foundation

Resource Centre for
Development

HTN

Network for Cost-effective
Technologies in Water Supply

Installation and Maintenance Manual for the Afridev Handpump



Revision 1-2003

Installation and Maintenance Manual for the Afridev Handpump

REVISION 1 - 2003

This manual has been prepared to cover installation and maintenance aspects of the Afridev Handpump.

This document results from several years of work carried out by Water & Sanitation Program (WSP) in partnership with SKAT-HTN, NGO's, handpump field workers and the private sector in several countries.

The experience gained in recent years has been incorporated into this Specification.

This Manual is intended to assist all users of the Malda Handpump, especially to give a guideline for the installation procedure and also for preventive maintenance.

Suggestions for improvements and requests for further information are welcome, and should be sent to SKAT at the address given below.

First edition: SKAT - HTN Publication, 1995

Revised edition: 1-2003 by Karl Erpf

Drawings: **skat_foundation**

Photographs: Meera & Ceiko Pumps Ltd. Hyderabad, India,
and **skat_foundation**

Copyright: SKAT - HTN
Provided the source SKAT - HTN is acknowledged, extracts of this publication may be reproduced.

Distribution: **skat_foundation**
Vadianstrasse 42
CH-9000 St.Gallen
Switzerland

Phone: +41 71 228 54 54

Fax: +41 71 228 54 55

E-mail: info@skat.ch

or karl.erpf@skat.ch

Homepage: www.skat.ch

Installation and Maintenance Manual for the Afridev Handpump

Contents

	Page No.
1.0 Background of the Afridev Handpump Development	4
2.0 Pump Features and Options	5
Part 1 Installation of the Afridev Handpump:	
3.0 Platform Construction	10
3.1 General Comments	10
3.2 Selection of Platform Type	12
3.3 Material required for Platform Construction	17
3.4 Preparation for Grouting the Platform for a Borehole	18
3.5 Grouting the Platform	20
3.6 Curing of Platform	23
3.7 Hard Core Layer and Fencing of Platform	24
3.8 Soak pit	24
3.9 Disinfecting the Well	25
4.0 Preparation for Handpump Installation	26
4.1 Decision on correct Cylinder Setting Depth	26
4.2 Materials and Tools required for Installation of “Down Hole Components”	27
4.3 Preparation of “Down Hole Components”	27
4.4 Important Information for Jointing PVC-U Pipes	30
4.5 Preparation of “Above Ground Components”	30
5.0 Handpump Installation Sequences	32
5.1 Installation of “Down Hole Components”	32
5.2 Installation of “Above Ground Components”	37

Part 2 Maintenance of the Afridev Handpump:

6.0 Preventive Maintenance	44
6.1 Preventive Maintenance Checks of Handpump	44
6.2 Maintenance of Pump Surrounding	45
7.0 Maintenance of Handpump	46
7.1 Diagnosis of Handpump Problems	46
7.2 Tools and Spare Parts required for Handpump Maintenance	46
7.3 Procedure of Dismantling “Above Ground Components”	46
7.4 Dismantling Threaded Pumprods	47
7.5 Re-installing of Threaded Pumprods	47
7.6 Dismantling Hook & Eye Pumprods	48
7.7 Re-installing Hook & Eye Pumprods	48
7.8 Dismantling and Re-installing FRP Pumprods	49
7.9 Re-assembling “Above Ground Components”	49
8.0 Repair of Handpump	50
8.1 Pulling out the whole Rising main	50
8.2 Fitting of Repair Sockets	51
8.3 Fishing of Dropped Handpump Parts	52
9.0 Recording of any Intervention	52

Annexes:

I. Trouble Shooting Chart for AFRIDEV Handpumps	53
II. List of Spare Parts for AFRIDEV Handpumps	54
III. Replacement Interval of AFRIDEV Wearing Parts	55
IV. Correct Storage of AFRIDEV Handpump Components	56
V. Example for recording of any Intervention	57
VI. Drawings of Fishing Tools for dropped Handpump Parts	58
VII. Technical drawing of “Repair Socket”	59

Installation and Maintenance Manual for the Afridev Handpump

1.0 Background of the Afridev Handpump Development

The Afridev started life in Malawi in early 1981. From the start, the aim was to produce a deep well handpump that was very easy to maintain at village level and could be manufactured in countries like Malawi, where industrial resources are limited. The Maldev pump head went into production in early 1982, and was a significant step forward in head design, with the users' needs given first priority.

Early in the field-testing of Maldev pumps, the ball bearings caused problems and the first Afridev pump head, which uses plastic bearings, was installed in Malawi in late 1982. Major efforts to resolve the "bearing problem" continued up to early 1985, when a plastic bearing design was finalised.

The focus of Afridev development shifted to Kenya in early 1983, although testing continued in Malawi. Important contributions were being made by field workers in several East African countries, as well as by experts from organisations in Europe, who provided specialist advice or laboratory testing facilities. International handpump design meetings were held in Kenya in late 1984 and early 1986, and throughout this period design and testing of pump heads, cylinders, rods and rising mains continued. At all times, the primary objectives were absolute simplicity of maintenance, and minimum quality control requirements to simplify manufacture.

Plastics research and development has played a vital role in the success of this project, of which the outcome is the Afridev pump system.

The Afridev handpump is manufactured in several developing countries in Africa & Asia. It is demonstrating that deep well handpumps can be maintained by village men and women, can be locally produced and can still be affordable and reliable.

2.0 Pump Features and Options

In the following pages you will find an overview of the pump features and the options, which are divided into "Recommended Options" and "Non-recommended Options".

Recommended Options:

Recommended options are all arrangements, assemblies and details, which have proven to be sustainable for many years and therefore are recommended to be used in future.

Non-recommended Options: Non-recommended options are all arrangements, assemblies and details, which have given problems during the last years and for which alternative solutions are available. Therefore, these options should **not be used for new installations**. However, these non-recommended options are still included in this manual, because many pumps with these configurations have been installed and they require spare parts for many more years.

Supporting documents:

Afridev Handpump Specification
Afridev Quality Control Guidelines
Afridev Injection Moulding Guidelines

Rubber Moulding Guidelines
Rubber Moulds for Afridev Components

Revision 0-2002

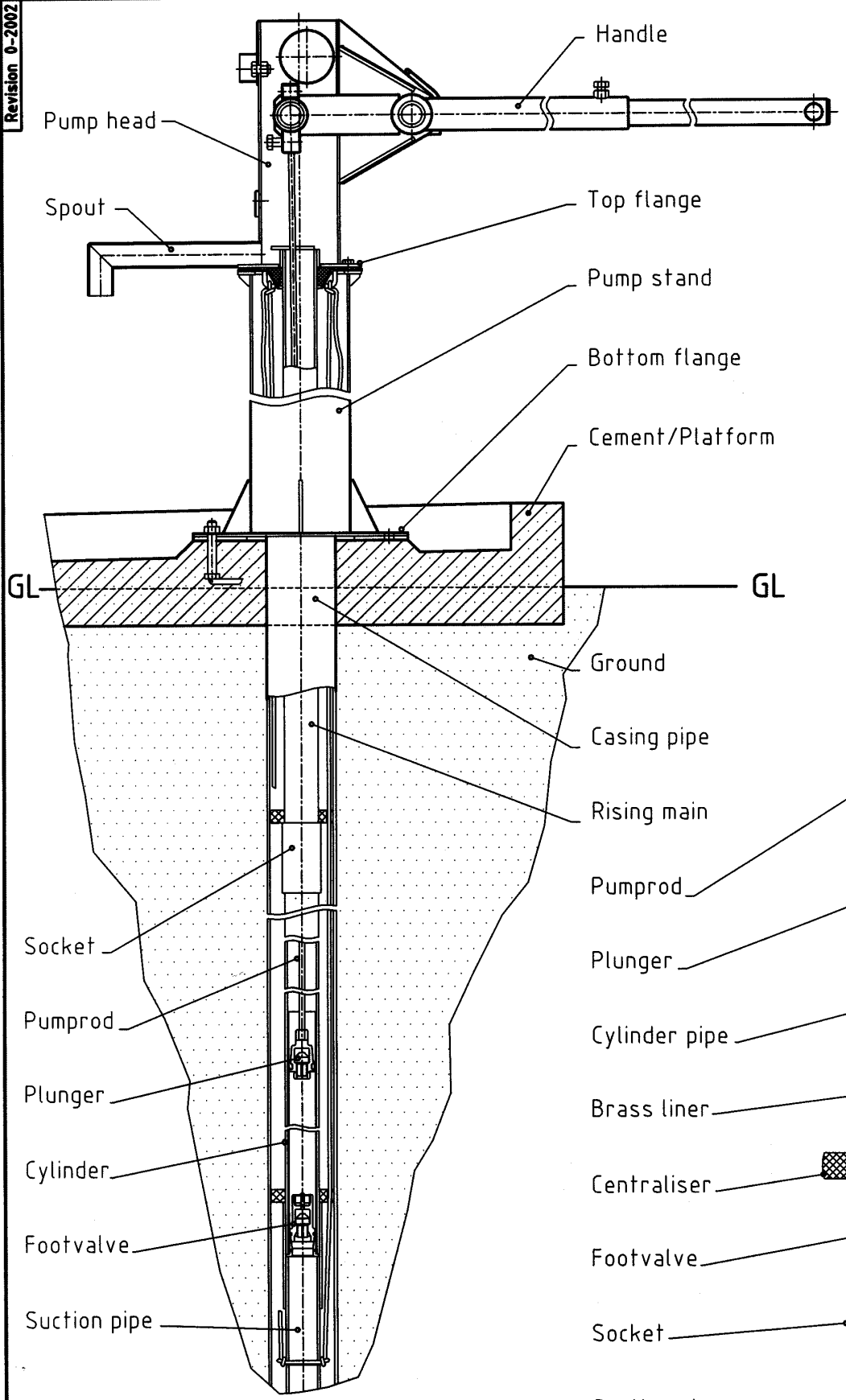

Drawn by: K. Erpf	07.12.01
Checked by: [Signature]	02.02.02
Released by: [Signature]	02.02.02
Scale: 1 : 10 (1:5)	
Afridev Standard Pump assembly International Handpump Specification	
D9109	

GENERAL TOLERANCE +/- 1 UNLESS OTHERWISE STATED

Scale 1 : 5

Afridev Handpump

List of options available:

Options	A	B	C	D
Pump head type	Pump head with short spout: (30 cm) drawing No. B2003	Pump head with long spout: (58 cm) drawing No. B2003	---	---
Pump stand type	Pump stand with bottom flange: drawing No. B2055	Pump stand with 3 legs: drawing No. B2050	Pump stand with ISO flange arrangement: drawing No. B2048	---
Rising main arrangement	PVC-U Rising main with "Sockets": drawing No. A2119	PVC-U Rising main with "Bell ends": drawing No. A2099	---	---
Cylinder arrangement	Brass plunger with Brass footvalve: drawing No. A2296	Brass plunger with Plastic footvalve: drawing No. A2257	Plastic plunger with Plastic footvalve: drawing No. A2070	---
Pumprod arrangement	MS- Pumprods with threaded connectors: drawing No. A2206	SS- Pumprods with threaded connectors: drawing No. A2209	FRP- Pumprods with Brass connectors: drawing No. A5889	SS- Pumprods with "Hook & Eye" conn. drawing No. A2110

Explanations:

- * not any longer recommended
- ** not recommended when PH value is < 6.5

Abbreviations:

ISO	International Standard Organisation
PVC-U	Polyvinyl Chloride (unplastcized)
MS	Mild Steel
SS	Stainless Steel
FRP	Fibre Reinforced Plastic

Example: Possible composition of a selected Afridev Handpump:

Pump head type	B
Pump stand type	C
Rising main arrangement	A
Cylinder arrangement	A
Pumprod arrangement	C

(For more clarification see the following 3 pages!)

Pump head types

(approx. scale = 1 : 10)

Option: **A**

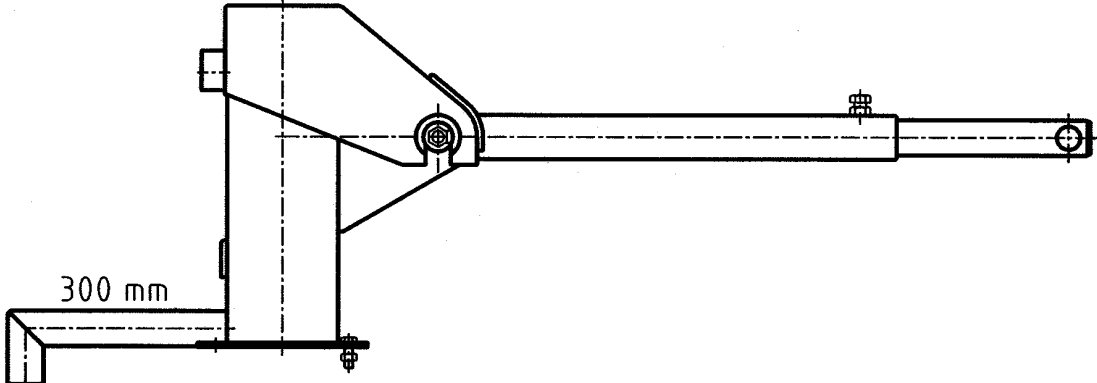

Option: **B**

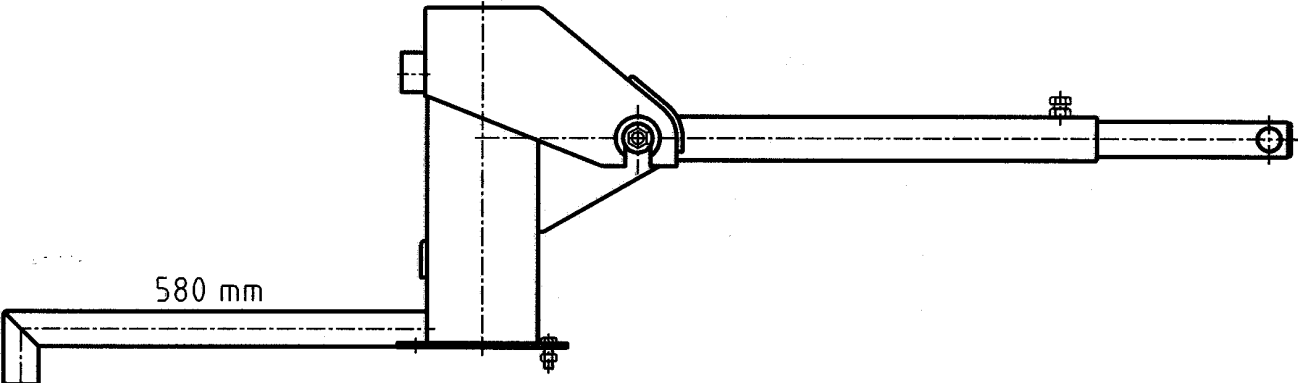

Pump stand types

(approx. scale = 1: 10)

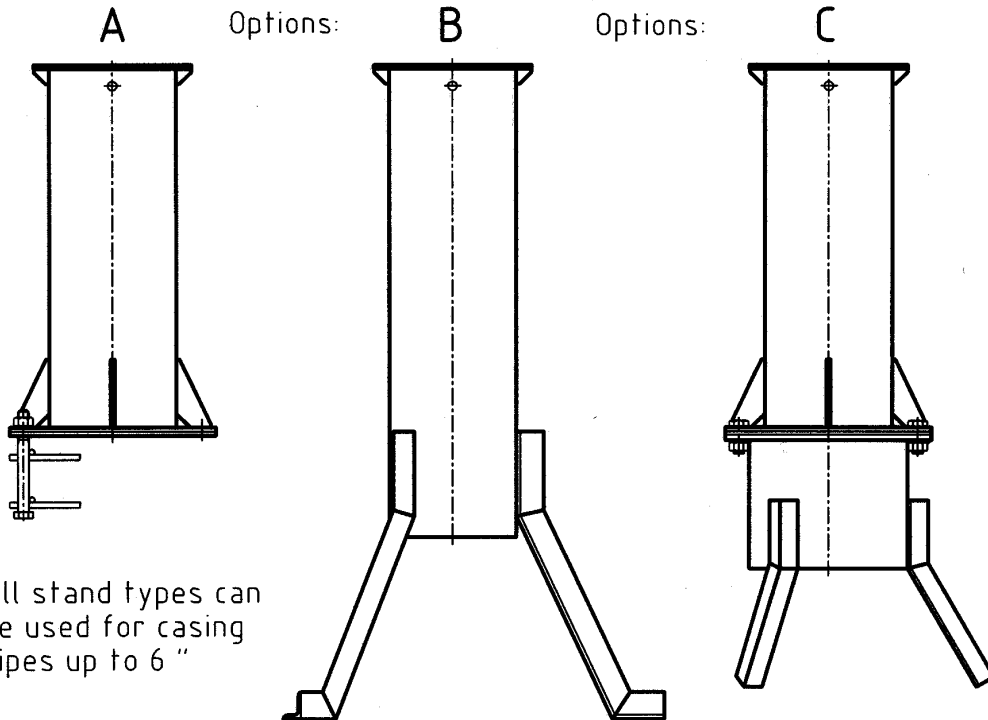

All stand types can be used for casing pipes up to 6"

Rising main arrangements

(approx. scale = 1: 10)

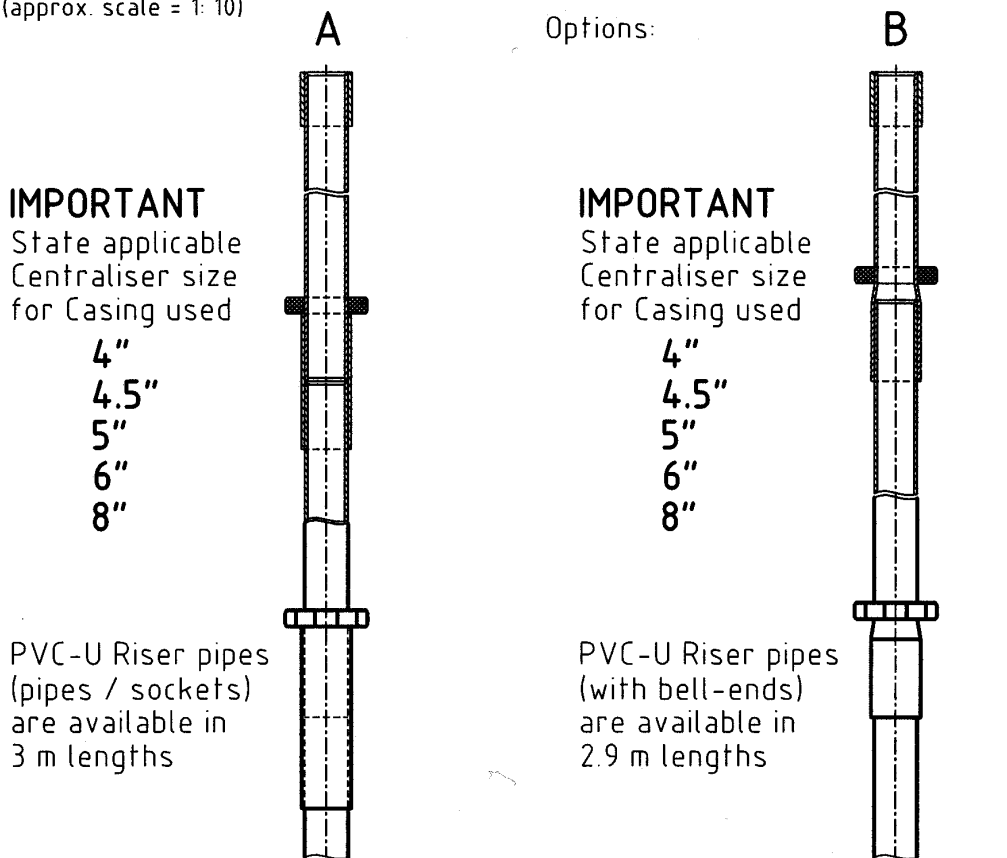

IMPORTANT
State applicable
Centraliser size
for Casing used

4"
4.5"
5"
6"
8"

PVC-U Riser pipes
(pipes / sockets)
are available in
3 m lengths

IMPORTANT
State applicable
Centraliser size
for Casing used

4"
4.5"
5"
6"
8"

PVC-U Riser pipes
(with bell-ends)
are available in
2.9 m lengths

Cylinder arrangements

(approx. scale = 1 : 5)

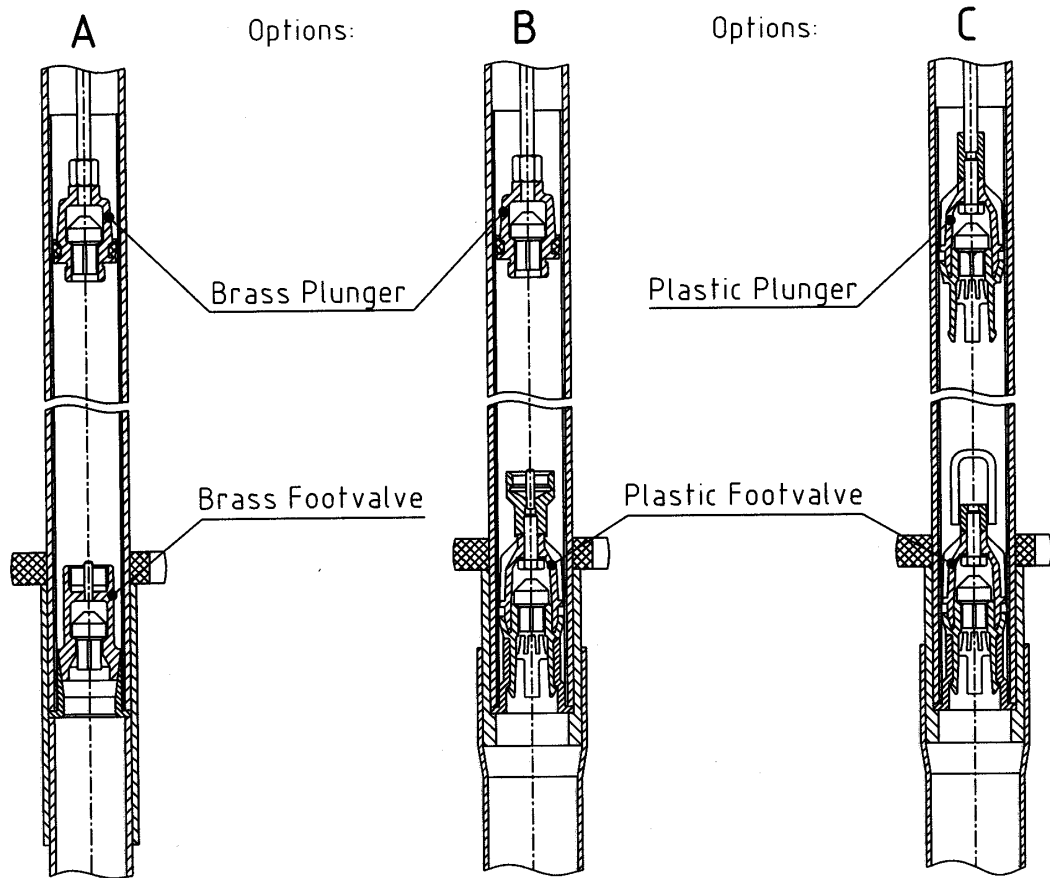

Pumprod arrangements

(approx. scale = 1 : 5)

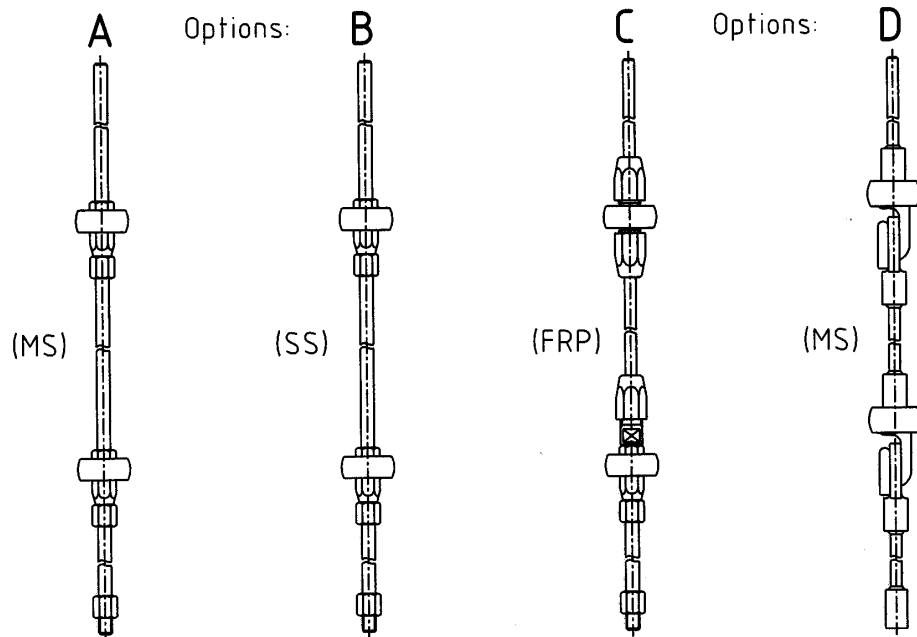

Options A,B and C are available in 3 m lengths - Option C in 3 or 6 m lengths

Part 1 Installation of the Afridev Pump

3.0 Platform Construction

3.1 General Comments

Sustained safe drinking water supply and sanitation facilities are essential to improve the living conditions of the rural population. The provision of safe water helps to combat water borne diseases and improves community health in general. Benefits of a safe water supply can reach far beyond considerations of public health and have a positive influence on the general well being, economic status and quality of life in a community.

3.1.1 Protection of Water Source

If a well site is chosen and the well drilled (or dug) into the ground at a site which is elevated and away from water logged areas during the rainy season, the water which percolates from an underground aquifer into the well should be pure enough to drink.

However, a water point obviously attracts a great deal of human contact. This is a potential source of contamination and should be protected against. The safety measures are as follows:

3.1.2 Well Siting

- The well should be in an elevated place, so that during the rainy season the water will run away from it, rather than into it.
- It should be at least 30 meters away from a latrine and uphill of the latrine.
- It should be at least 30 meters away from a cattle kraal, and uphill of the kraal.
- It should be well away from any depressed area in the ground, such as hollows that are used for rubbish tipping, hollows that are used for brick making or any other areas where water might collect.

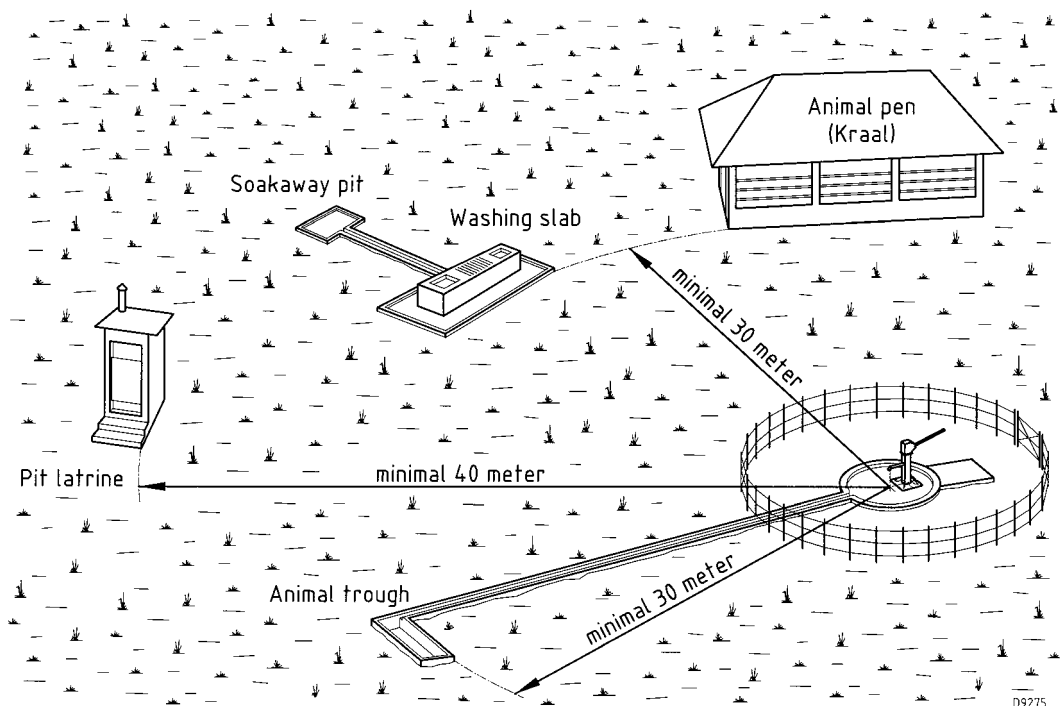

D9275

3.1.3 Hygiene Education and Water Supply

Throughout the water supply process, it is vital to bear in mind the important linkages between health, hygiene education and water. An awareness of the intimate relationships between these factors should be made clear to all water users.

Before the arrival of a new or improved water supply system, the water users of a village should receive hygiene training with regard to the collection, storage and use of water. For example, the transmission of disease through contaminated water may not be understood in the community.

Cleanliness in the area of the water point is an important factor in the overall impact of the introduction of a new or improved facility.

If the surrounding area is not kept clean and free of animals, debris, waste and stagnant water, the water point could become a hub for the transmission of many infectious diseases.

In this respect, the ability of the community to manage the system and ensure regular cleaning of the water point is vital.

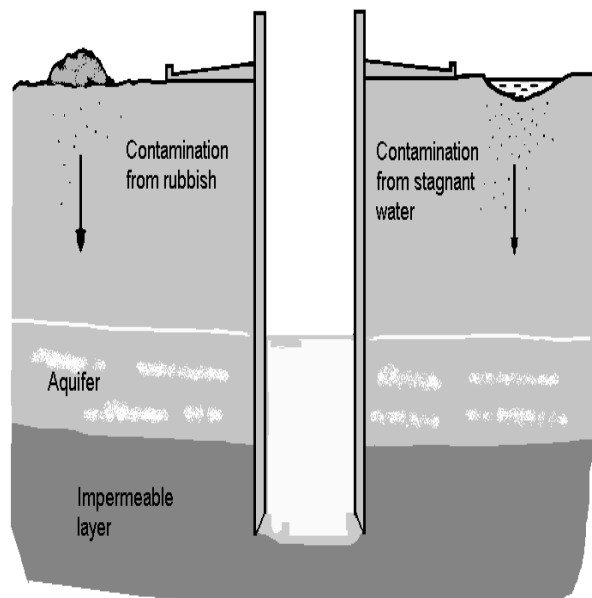

3.1.4 Platform Design

If the area around a well is allowed to become dirty, and waste and stagnant water is allowed to accumulate, it will become a source of infection for the users. Standing in bare feet in stagnant water or mud is a serious health risk in the tropics since the open water provides an ideal breeding ground for many types of parasite and/or disease carrier. Awareness of the direct links between hygiene and water must start at the collection point, otherwise the possible benefits from an improved water supply will be lost.

The construction of a platform (or slab) at the wellhead is an important contribution to the general hygiene in a community. In addition to discouraging the accumulation of stagnant water at the surface, the slab will help to prevent the contamination of the well through the infiltration of dirty water back into the aquifer.

The following points are important:

- a) The slab surrounding the water point should be made as wide as possible from properly made reinforced concrete of good quality. The water outlet (spout) should be placed in the centre of the slab, so that it collects the spill water, which then can run away through the drainage channel.

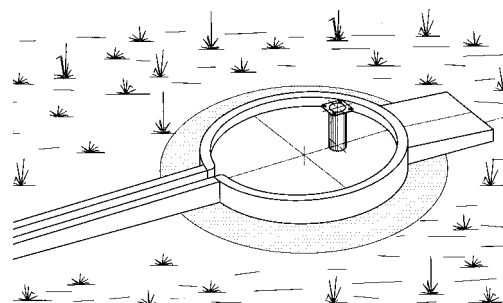

- b) All surfaces should slope towards the drainage channel and the edges of the slab should be raised.
- c) The slab should be well reinforced with steel wire, to prevent cracking. Dirty water can pass through cracks in a poorly constructed slab and contaminate the well beneath.

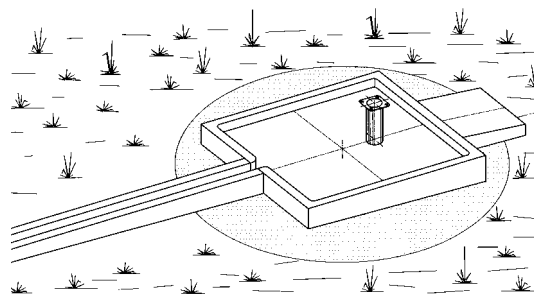

The shape of the slab is not as important as its capacity to drain water away from the well as quickly as possible and to ensure wastewater dispersal in a hygienic manner.

Where possible, the drain can lead to an area of vegetation, such as banana plants or a vegetable garden. If this is not an option, a soak-pit can be built or a trough for watering livestock can be provided.

It is important that construction of the slab does not commence until the soil around the well, which was disturbed by the construction activities, has had an opportunity to settle properly.

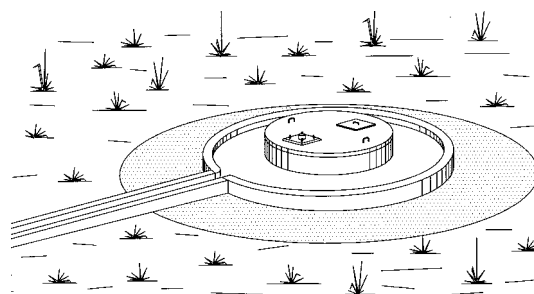
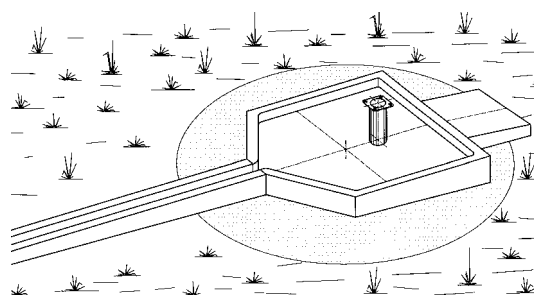

3.2 Selection of Platform Type

Consultation with the community is a must before a decision is taken on the platform layout. In the following three pages you will find typical platform designs for handpumps installed on boreholes or on dug-wells. These are indicative layouts and can be modified to suit communities needs, which may include the following:

- a) Facilities for washing clothes,
- b) Facility for bathing,
- c) Trough for cattle watering,
- d) Collection of water for small scale irrigation etc.

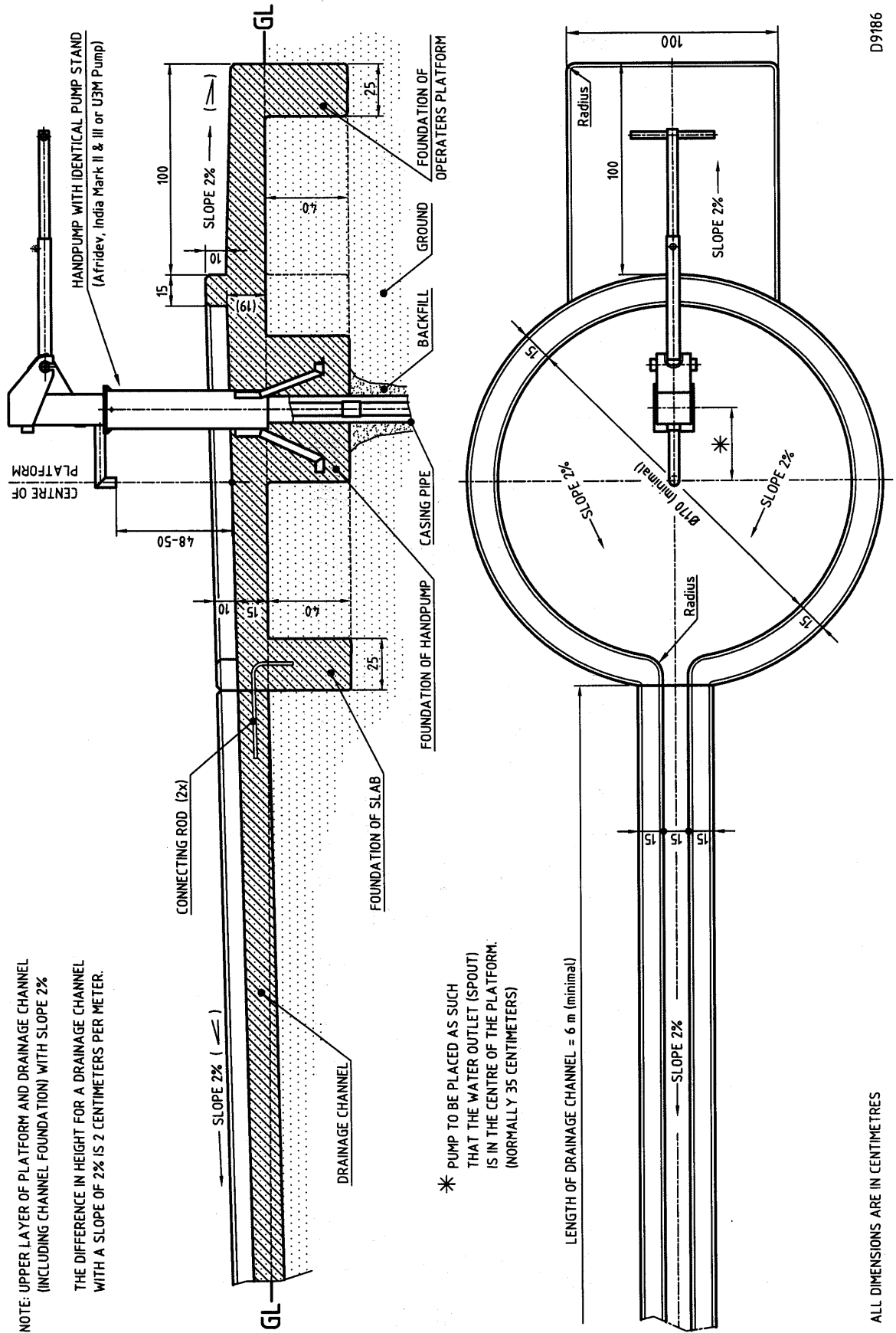

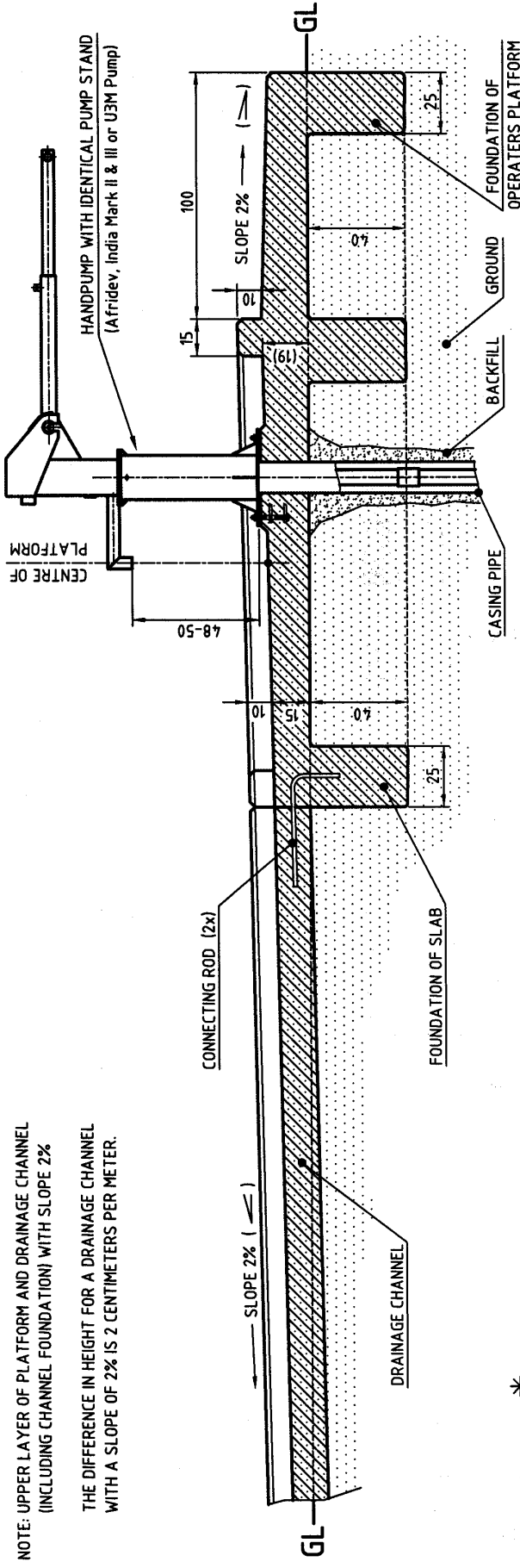

NOTE: UPPER LAYER OF PLATFORM AND DRAINAGE CHANNEL (INCLUDING CHANNEL FOUNDATION) WITH SLOPE 2%
 THE DIFFERENCE IN HEIGHT FOR A DRAINAGE CHANNEL WITH A SLOPE OF 2% IS 2 CENTIMETERS PER METER.

* PUMP TO BE PLACED AS SUCH THAT THE WATER OUTLET (SPOUT) IS IN THE CENTRE OF THE PLATFORM. (NORMALLY 35 CENTIMETERS)

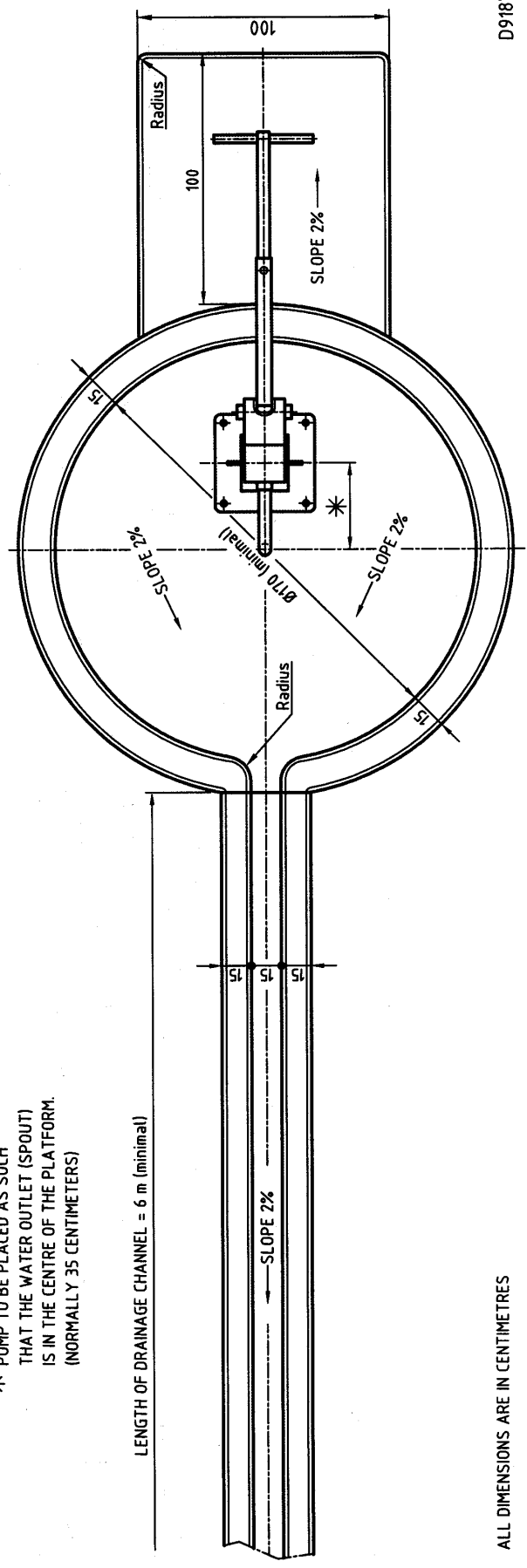

LENGTH OF DRAINAGE CHANNEL = 6 m (minimal)

ALL DIMENSIONS ARE IN CENTIMETRES

D9187

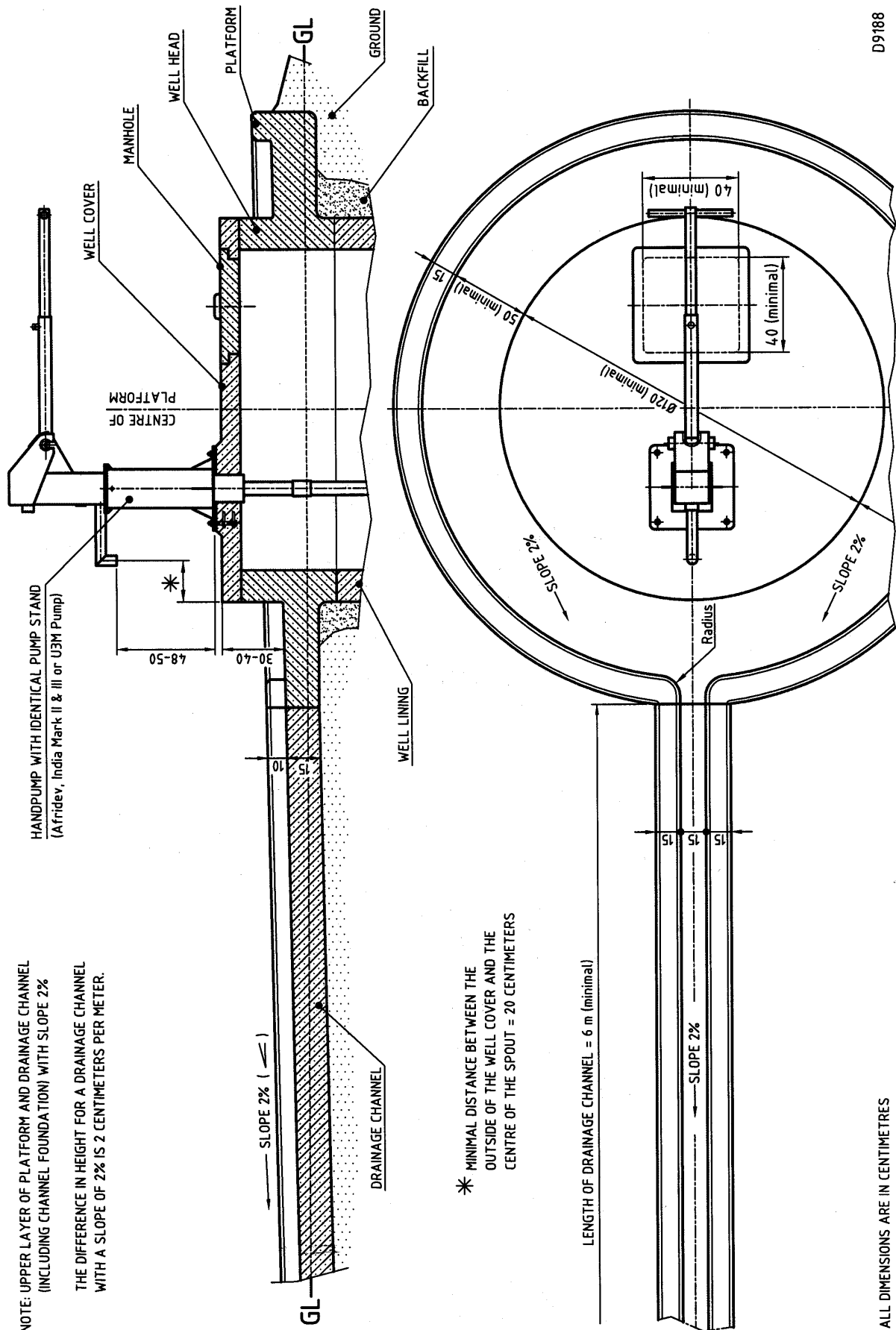

NOTE: UPPER LAYER OF PLATFORM AND DRAINAGE CHANNEL (INCLUDING CHANNEL FOUNDATION) WITH SLOPE 2%

THE DIFFERENCE IN HEIGHT FOR A DRAINAGE CHANNEL WITH A SLOPE OF 2% IS 2 CENTIMETERS PER METER.

* MINIMAL DISTANCE BETWEEN THE OUTSIDE OF THE WELL COVER AND THE CENTRE OF THE SPOUT = 20 CENTIMETERS

LENGTH OF DRAINAGE CHANNEL = 6 m (minimal)

ALL DIMENSIONS ARE IN CENTIMETRES

3.2.1 Fencing of Water Source

In addition to constructing a slab, it is important to erect a good fence around the water point. This can be done immediately after the construction of the well is finished, and should give enough space to operate the handpump. The advantages of fencing are that it serves to define quite clearly, for the whole community, the area of the well and it keeps animals away from the wellhead. In some cases, it may be necessary to have a gateway to keep out smaller animals such as pigs and goats.

The fencing can be made of suitable local materials like wood or stones. Problems of replacement and repair can be avoided altogether, by using a living hedge as fencing. Whatever type of fencing is used, it is important that access by the well users is guaranteed.



3.3 Material required for Platform Construction

3.3.1 Recommended Masonry Tools for Platform Construction

Item	Approx. Quantity
Shovel /Scoop	3 nos
Spade	1 no
Pick or Crow bar	2 nos
Mason's trowel	2 nos
Levelling plank (0.5 and 2 m)	1 each
Rubber bucket (for concrete)	4 nos
Steel bucket (for water)	2 nos
Measuring tape (3 m)	1 no
Spirit level	1 no
Platform shuttering (Steel form or wooden material)	1 no
Tamper sticks (for removing trapped air)	1 no

3.3.2 Materials and Consumables for Platform Construction (Borehole)

Item	Approx. Quantity
Washed Sand (without too much mud content)	2 cubic meters
Gravel (approximately Ø20 mm)	4 cubic meters
Cement (bags of 50 kg)	8 bags x 50 kg
Burned bricks (3" x 4.5" x 9")	100 nos
Wire netting for Platforms (50 x 50 x Ø3 mm)	1.7 x 1.7 m
Reinforcement bars for Dug-well covers (Ø6 - 8 mm)	15 m
Binding wire for connecting reinforcement bars	10 m
Hessian cloth for curing of platform	to cover platform
Pump stand (for stand with 3 legs)	(1 no)
Anchor assembly (for stand with Bottom flange)	(1 no)
Wooden board (protection against contamination)	1 no (bolted on flange)

3.3.3 Materials and Consumables for Platform Construction (Dug-well)

Since most Dug-wells differ in size, the quantity of material required for the construction of a platform including Well head and Well cover, has to be calculated.

3.3.4 Materials and Consumables for Soak Pit Construction

Additional materials used for the construction of a Soak pit:

Sand, Pebbles, Stones of different sizes, Bricks, Bamboo matting, Hessian cloth or Jute-bags.

3.4 Preparation for Grouting the Platform for a Borehole

If the protruding well casing is not already closed with a top cap, cover it with a clean piece of a cloth or a plastic bag and secure it with a string. This cover should remain in place until the pump stand is finished and the handpump installation takes place. Step by step manufacturing of the platform is explained in the following sequences:

3.4.1 Setting out

After the decision has been made, in which direction the handpump has to be placed, the first peg is placed 35 cm from the protruding casing pipe. This peg should take advantage of the natural slope of the area i.e. it should be sited downhill of the casing if at all possible.

This peg is the centre of the platform and from this position the Centre lines (CL) are set and marked with pegs. Clear the platform construction area of bush and surface irregularities.

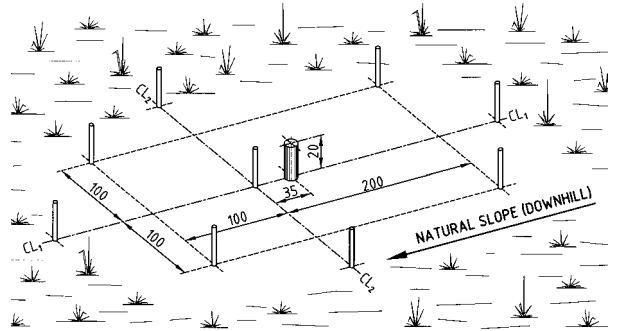

3.4.2 Marking Foundation

Make a loop at the end of a string and place it over the peg in the centre. Attach another peg at the required distance (75 cm) to the other end and mark the inner circle (radius 75).

Afterwards, use the same system as above to mark the circle with radius 100.

Mark all other measurements as given in the picture. For better marking, small pegs or short branches can be placed in 5 to 10 cm distances along the marked line.

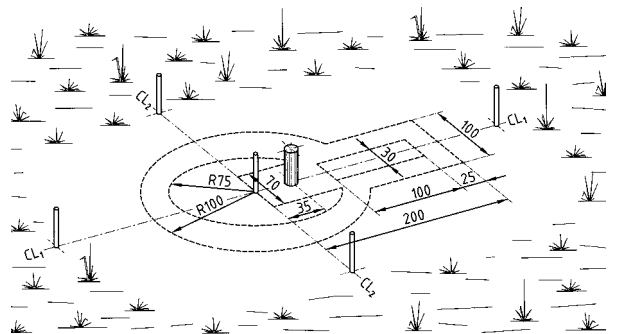

3.4.3 Digging Foundation Trenches

Dig the trench for the foundation carefully and make sure that the marked outline of the platform does not get damaged during digging. The foundation trench is finished as soon as the depth is a uniform 40 cm, which can be checked from any point of the prepared surface.

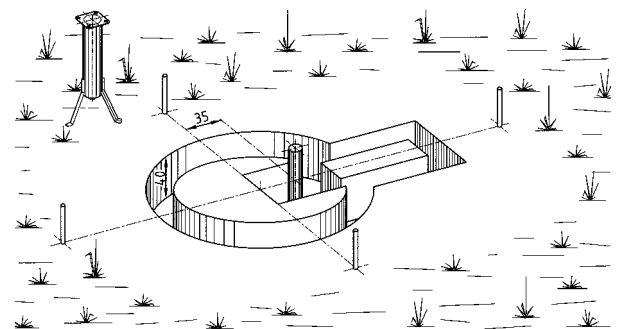

3.4.4 Placing the Pump stand

It is important that the pump stand, which is placed over the protruding casing pipe is at the correct height and is absolutely vertical.

The pump stand needs to be secured well with stones or wooden struts, so that it does not change its position during the grouting process.

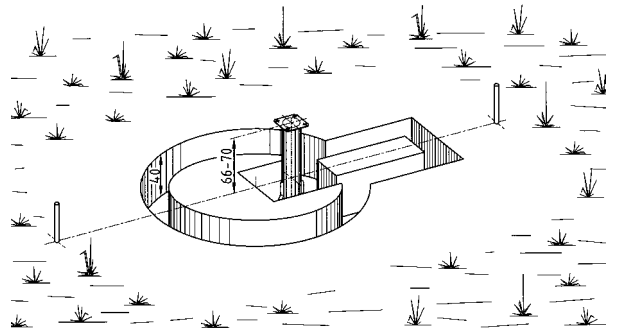

Remove the cover of the protruding casing pipe. Place the pump stand over the pipe and check the centricity of the casing inside the standpipe.

Make sure that the flange of the pump stand is pointing in the right direction.

Put stones underneath the legs of the pump stand, until the flange is at the required height of 66 to 70 cm from the platform base (or 106 to 110 cm from the floor of the excavations).

It is important to check that the flange of the pump stand is completely horizontal in all directions. Check this using a spirit level and adjust the pump as required. To secure this position, use stones or wooden struts.

3.4.5 Final Preparation prior to Grouting of Platform

Before starting with any concrete work, check whether all preparation work is completed, so that the different cement work (wet in wet system) is not interrupted too long. It is very important that enough raw materials have been collected to complete the following steps without interruption before any mixing of concrete should start.

- Cement, sand, gravel, bricks (and enough water),
- Reinforcement bars or netting,
- Shuttering material (or form work) for the platform ring and drainage channel,
- Steel bars for connecting platform and drainage channel (2 off)

Prepare enough concrete for filling the entire foundation space up to the ground level.

The mix should be 1:2:3.

This means 1 volume of cement, 2 volumes of sand and 3 volumes of gravel.

Mix the cement, sand and gravel thoroughly, before water is added.

1 part of cement



2 parts of sand



4 parts of gravel

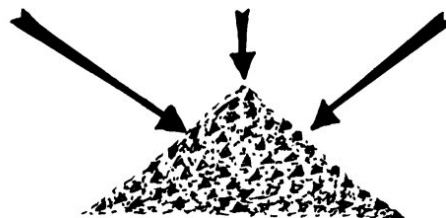

mix thoroughly before adding water

For grouting sequences see following pages:

3.5 Grouting the Platform

3.5.1 Fill Foundation with Concrete.

Before the concrete is compacted, check again the flange for horizontality and adjust if necessary. Compact with a vibrator or by hand (use a tamper) to remove trapped air.

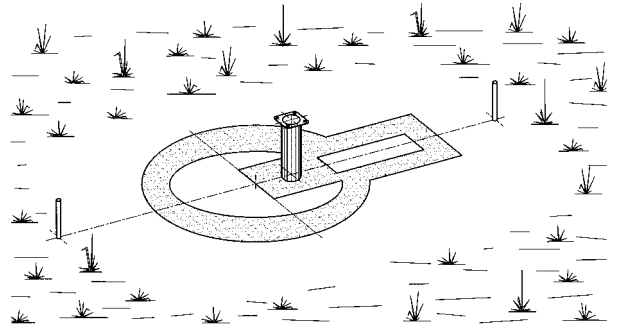

3.5.2 Reinforcement of Platform and Placing of Shuttering

Place (and bind together) suitable reinforcement bars on the platform area, or lift preformed netting over the pump stand. Support the reinforcement with small stones or with the help of cement cubes in order to lift it to the required height. The position of the reinforcement should be between 2 to 3 centimetres below the finished cement surface. Place the shuttering (formwork) and support it with pegs or heavy stones.

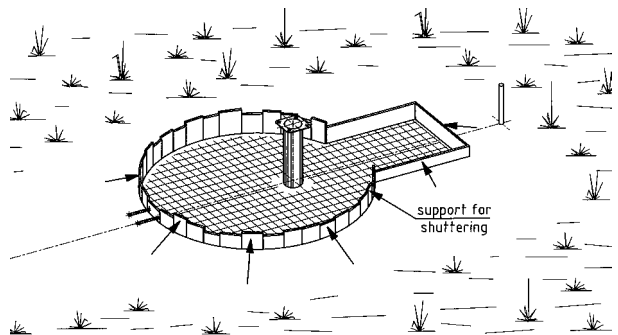

3.5.3 Casting of Well Platform and Operation Platform

Prepare enough concrete for casting the platform. Fill the platform with a concrete layer of 12 cm and compact by tamping.

After a curing time of approximately 1 to 2 hours, the shuttering can be removed carefully.

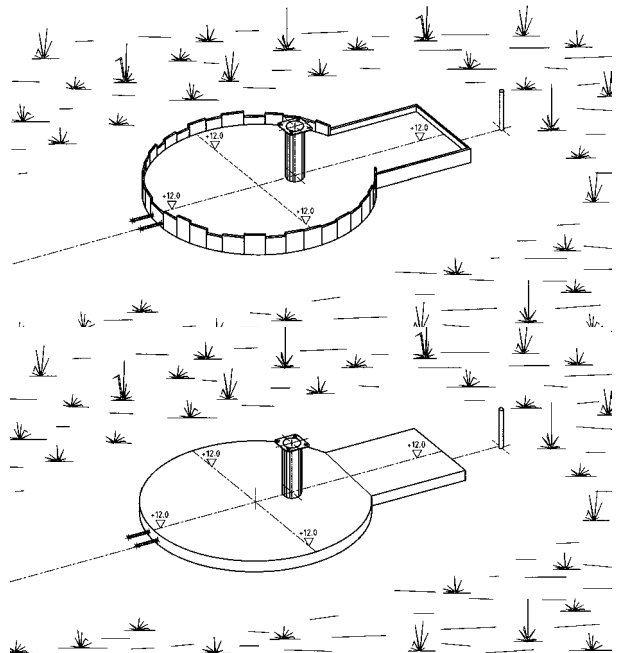

Prepare enough mortar for the final layer with slope and bricks for constructing the ring of the platform.

Now the final layer for the slope can be applied. Make sure that the slopes are in the right direction.

After a short while of applying the final layer (15 to 30 minutes), the bricks for the ring of the platform can be placed.

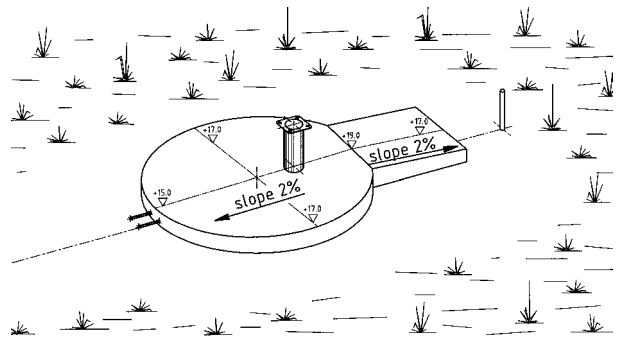

3.5.4 Casting of the Drainage Channel

During the curing time of the well platform, all work for casting the drainage channel can be started. Proceed as follows:

Dig the required trench for the drainage channel and make sure that the 2% gradient on the downward slope of the platform continues right to the end of the channel.

Place and secure the formwork of the 6m long drainage channel.

If required, place the reinforcement bars or netting.

Prepare sufficient concrete and cast a layer of 12 cm.

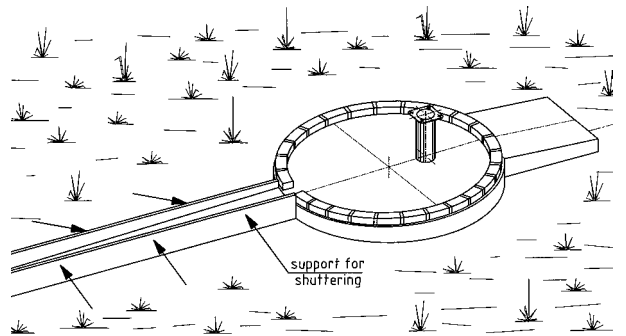

After a curing time of approx. 1 to 2 hours, the shuttering can be removed carefully. Prepare mortar for final layer and enough bricks for the two rims on drainage channel. The bricks can be placed 15 to 30 minutes after the final layer has been applied.

After the bricks are in position, all final work (like finishing and smoothing all surfaces of the platform and the drainage channel) can start.

Make sure that all top corners of the platform ring and the rims of the drainage channel are made with chamfers and a radius is applied between the platform and the ring.

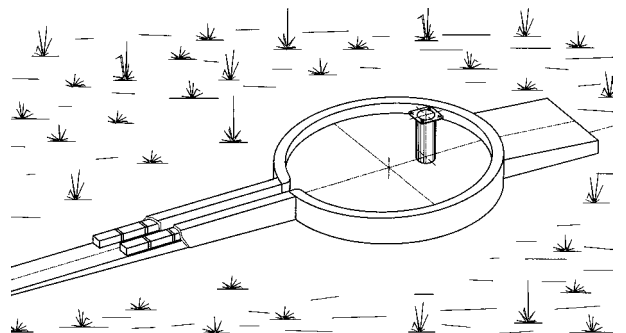

3.5.5 Grouting of Platform for ISO Flange arrangement

When grouting of a platform for the ISO Flange, the normal procedures as described before can be followed.

The only difference to the platform for the pump stand with legs is that the ISO Flange has shorter legs and therefore the foundations at the casing pipe can be made more shallow.

When placing the ISO Flange for grouting, make sure that the flange needs to be 7 cm above the finished surface of the slab.

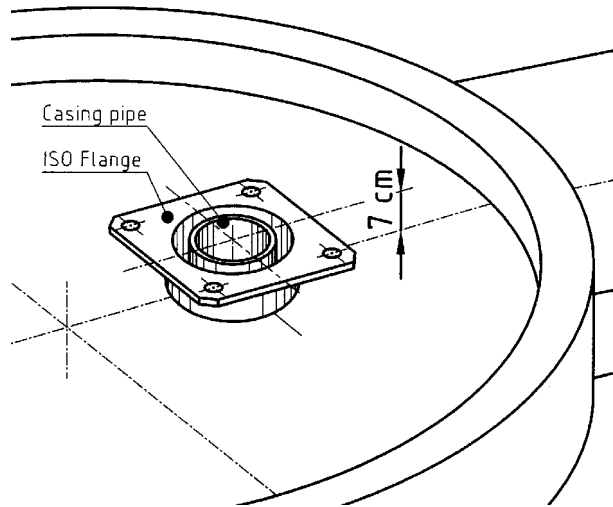

3.5.6 Grouting of Platform for Pump stand with Bottom Flange

When grouting of a platform for the Pump stand with Bottom Flange, the normal procedures as described before can be followed.

The only difference to the platform for the pump stand with legs is that the Bottom Flange is placed in top of the slab and only the Anchor assembly needs to be grouted.

Therefore the foundations at the casing pipe can be made more shallow. It is also advisable to raise the surface of the flange by approximately 3 cm, to make it exactly level. (see picture).

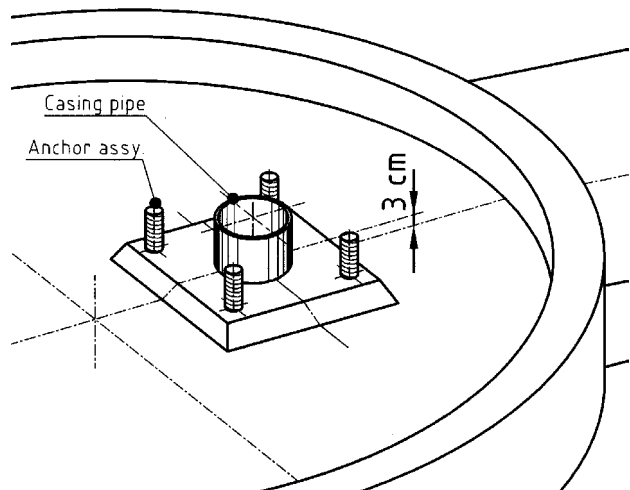

When placing the Anchor assembly for grouting, make sure that the Anchor bolts are protruding the top face of the raised surface by 4 cm.

3.5.7 Grouting of Covers for Dugwells

Dugwells need to be closed by a strong cover, on which the handpump can be installed.

Form a ring of bricks according to the well diameter and cover the whole surface with with plastic sheets.

Place the Anchor assembly, a wooden plug (forming the "Manhole"), two handles and the reinforcement bars, and fix the whole assembly with binding wire prior to grouting.

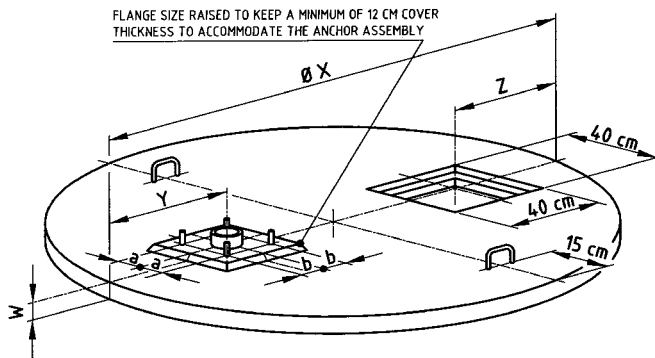

* SEE DRAWING OF PUMP FLANGE

Single Well Covers

Well outside Ø X	Dimension Y	Dimension Z	Cover thickness W	Dimension a *	Dimension b *
1.2 to 1.5 m	50 cm	30 cm	Ø10 cm	according to pump configuration	according to pump configuration
1.5 to 1.8 m	50 cm	35 cm	Ø10 cm	according to pump configuration	according to pump configuration

For dug well covers with an outside Ø over 1.8 m, covers need to be split and supported by beams.

Grouting procedure and curing time etc. is comparable to the construction steps of the platforms.

For exact positioning of the Anchor assembly and the plug for the "Manhole", see sketch at the left side.

For more details see also "3.5.6 Grouting of Platform for Pump stand with Bottom flange" on page 21.

3.6 Curing of Platform

Following the final touch of the platform, protection is required from being destroyed:

As soon as all final work is completed, all cement work needs a curing time of at least one week.

During the curing period, the platform needs to be watered regularly, so that it never gets dry.

Partitions made of clay or other material blocks the water from being drained after watering.

Before leaving the water point, cover platform and drainage channel with thorn bush, so that it is well protected from being destroyed by passing people or by animals attracted by the water.

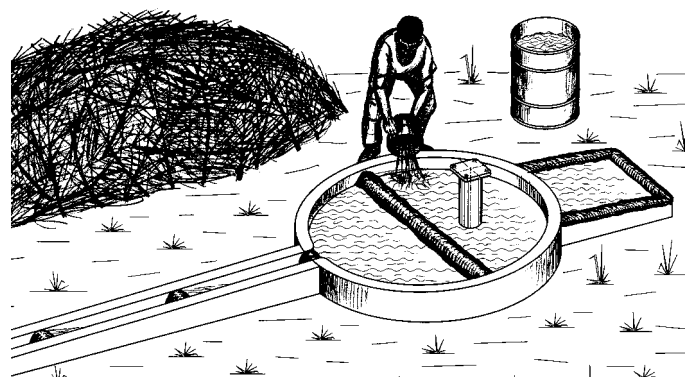

3.7 Hard Core Layer and Fencing of Platform

3.7.1 Hard Core Layer around the Platform

A hard core layer should be placed around the platform. This acts as a protection of the concrete platform and prevents spill water to create a swampy muddy area. Proceed as follows:

Mark the outside line of the hard core layer and dig as much as required, so that the brick or stone layer is level with the ground surface when finished.

Bricks or stones are placed on mortar or sand and the joints are filled with mortar.

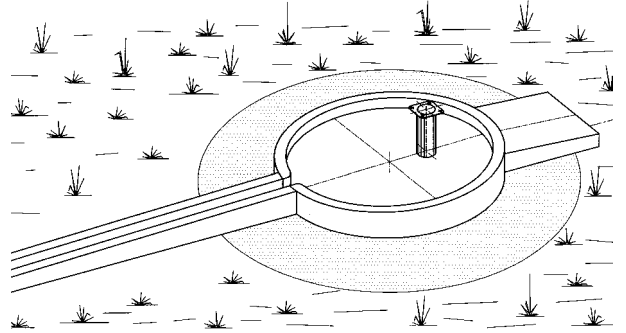

3.7.2 Fencing of Platform

The entrance of the fence should be able to be closed or be made as narrow as possible, so that no animal is able to enter the well point. (see also 3.1.5)

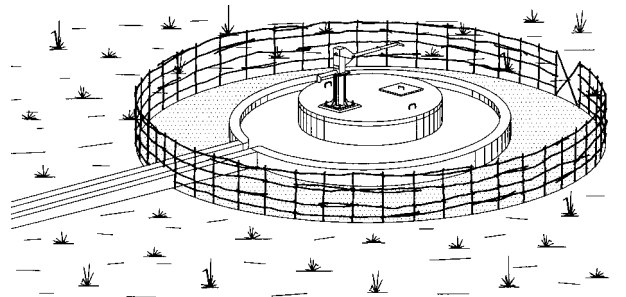

3.8 Soak pit

Construct a soak pit if natural drain is not available. In the picture you will see a typical construction of a soak pit.

Fill the excavated hole with stones, broken bricks, gravel and cover with sand.

To prevent that sand is washed away, fix a mud pot (with holes at the bottom) at the end of the drainage channel, so that the spill water can drain slowly.

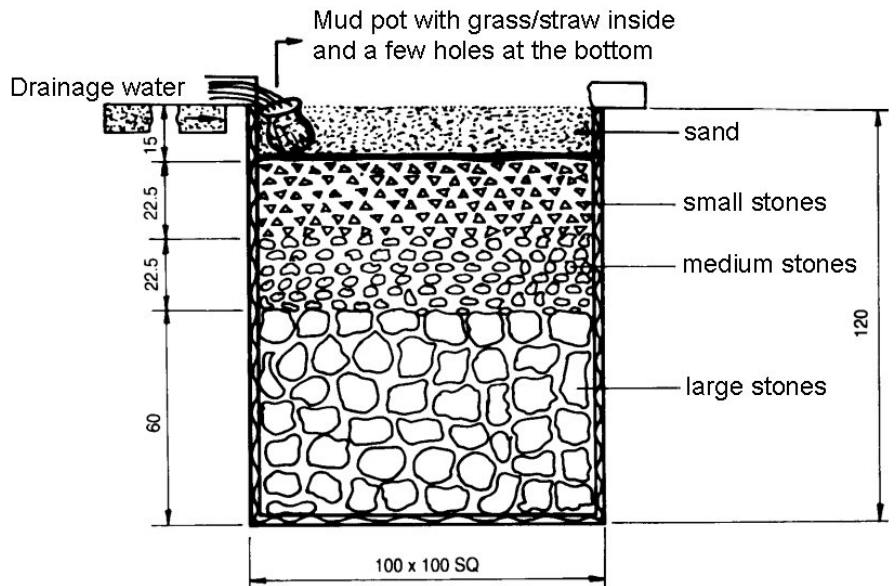

3.9 Disinfecting the Well

As soon as the curing time is over and the platform is ready for installation of the handpump, the well needs to be disinfected with chlorine.

Many of the diseases which are common in the communal lands are carried by water, especially from unprotected wells, water holes, rivers and dams.

Dysenteries, diarrhoeas and typhoids can arise as a result of drinking water that is infected. The disease-carrying organisms found in the water can be effectively killed by disinfecting the water with chlorine.

Therefore we are recommending to disinfect the well shortly before the installation of the handpump takes place. Proceed as follows:

Mix 300 grams of bleaching powder thoroughly in 15 litres of water in a bucket and pour the solution into the borehole.

The required dosage for dug-well can be calculated as follows:

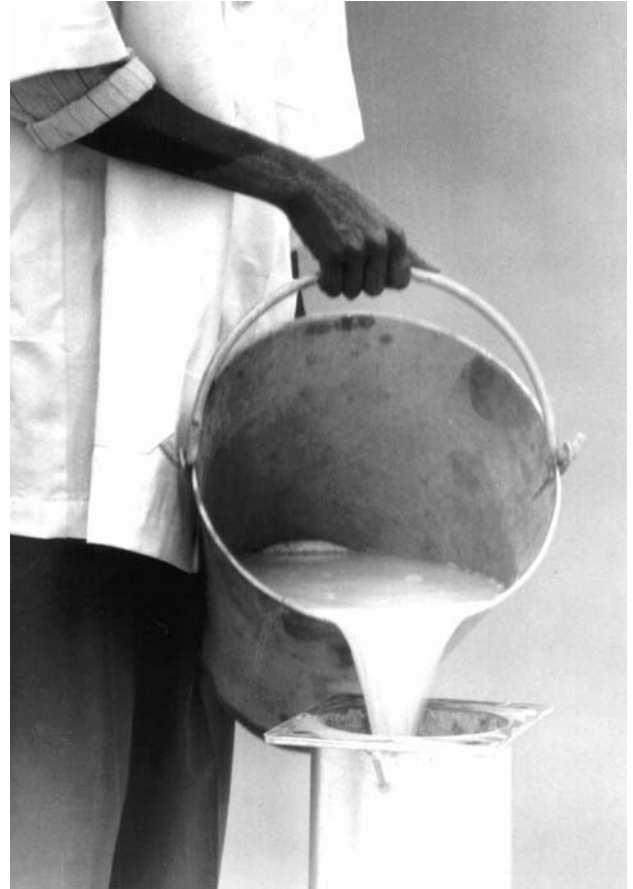

4.0 Preparation for Handpump Installation

4.1 Decision on correct Cylinder Setting Depth

4.1.1 Boreholes

The cylinder setting (intake of the Suction pipe) should be 6 meters below the expected Dynamic Water Level (DWL) in the dry season. This can be done in two ways:

- a) **By using the yield of borehole and drawdown.**

$$DWL = SWL + (Q_{hp} \times D) : Q_{ty}$$

DWL = Dynamic Water Level

SWL = Static Water Level

Q_{hp} = Maximal pump discharge per second (0.33 litres/sec. for the Afridev)

Q_{ty} = Borehole test pump yield in litres per second (tested after drilling)

D = Draw-down in metres (noted during yield test after drilling)

- b) **When figures of the “Yield test and Draw-down” of the borehole are not available:**

If for any reason the information on the yield of the borehole and the drawdown is not available, the bottom of the Suction pipe should be placed at least 10 meters below the SWL in the dry season.

Of the above two methods, the first method is more accurate.

Please note: The bottom of the Suction pipe should be always set at least 3 meters above the bottom of the borehole to minimise pumping of silt and sand.

4.1.2 Dugwells

The cylinder setting (intake of the Suction pipe) should be at least 1 meter below the expected DWL in the dry season.

Please note: The bottom of the Suction pipe should be always set at least 0.5 meters above the bottom of the dugwell to minimise pumping of silt and sand.

4.2 Material and Tools required for Installation of “Down Hole Components”

4.2.1 Tools and Equipment

- | | | |
|----|------------------------------|--|
| a) | measuring tape | marking exact length and square cutting line, |
| b) | pencil / permanent marker | marking prior to cutting, |
| c) | hacksaw | easy cutting of PVC-U pipes, |
| d) | pocket knife | deburring of inside edges (inside chamfering), |
| e) | rasp or coarse file | chamfering the inside and outside edges, |
| f) | sand paper 60 – 80 grit | roughening of jointing surfaces, |
| g) | brush, flat 50 x 4 mm | for outside application of solvent cement, |
| h) | brush, flat 25 x 3 mm | for inside application of solvent cement, |
| i) | white absorbent paper | cleaning paper (or toilet paper), |
| j) | small bowl (Bakelite or tin) | for easy application of solvent cement, |

4.2.2 Material

- | | | |
|----|----------------|-----------------------------|
| a) | Cleaning fluid | Carbon tetra chloride base, |
| b) | Solvent cement | Tetrahydrofurane base, |

4.3 Preparation of “Down Hole Components”

- 4.3.1 Prepare a suitable working place not too far from the well point (place two logs for resting the pipes in a clean place above the ground), preferably in a shady place.
- 4.3.2 Calculate all pipes needed for the required installation length and add a cylinder, a suction pipe, the needed number of rising main centralisers and the top sleeve.
- 4.3.3 Slide all centralisers over the pipes until they rest at the beginning of the bell-ends. One centraliser is placed at the end of the cylinder (use a little water for easy sliding).
- 4.3.4 Place all pipes and the cylinder with suction pipe neatly next to each other on top of the two logs and clean all parts from dirt and dust.
- 4.3.5 The rope for supporting the rising main during the jointing process needs to be stretched out on the ground and straightened (removing all kinks). Then the two ends should be brought together to find the midpoint of the rope, where a knot needs to be made. Place the rope neatly on the ground near the well platform and make sure that it is in a clean place, to avoid contamination of the well during installation.

- 4.3.6 Mark each pipe end with a pencil or permanent marker at 115 mm (the position where the bell-end will rest after jointing).

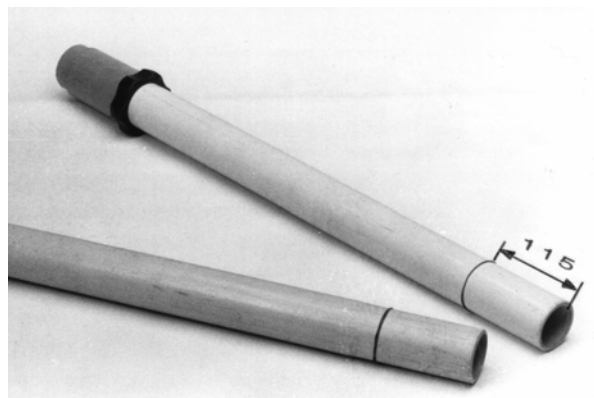

4.3.7 If one of the pipes needs to be shortened, mark the exact position (a line around the whole pipe) and cut along the line with the hacksaw, remove the burrs with a knife.

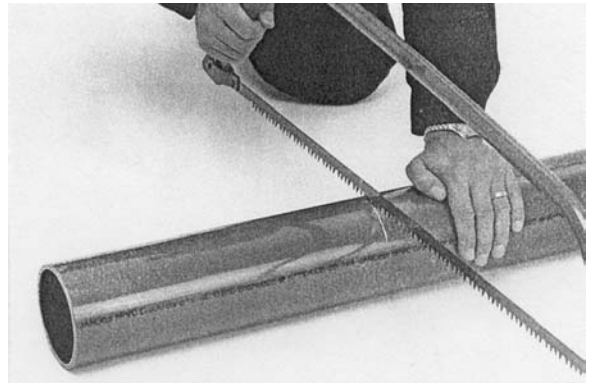
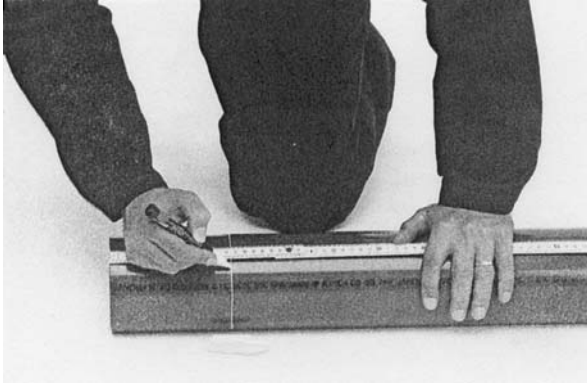

4.3.8 Check all pipe ends for exact chamfer sizes, make chamfers if necessary with the rasp or coarse file (Note: both inside and outside chamfers are required, see sketch).

chamfered 5 x 15°
(inside and outside)
all sharp edges rounded

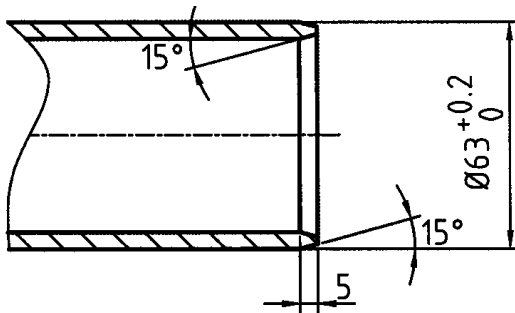

4.3.9 All pipe ends (outside) up to the marked line and also all bell-ends (inside) need to be slightly roughened with sand paper until the surface appears matt.



4.3.10 Then the roughened surfaces need to be cleaned properly with the cleaning fluid to ensure that they are free from any oil or grease (use a new paper with cleaning fluid as soon as any dirt is visible on the white paper).

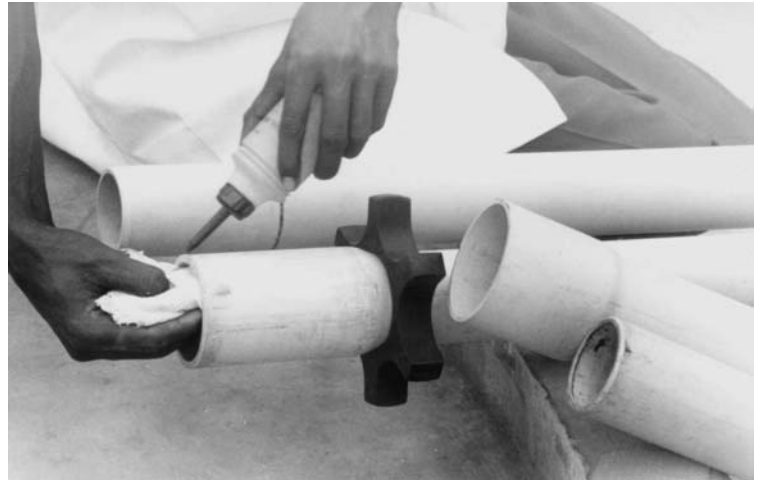

4.3.11 Let the cleaned surfaces dry for approximately 5 minutes and make sure that nobody touches the prepared surfaces with their hands.

4.3.12 Pass one end of the rope through the 10 mm hole of the suction pipe until the rope stops because of the knot. A second knot needs to be made at the other side of the suction pipe, so that the rope is fixed and cannot be pulled out to either side.

4.3.13 Clean the apron of the pump point, and prepare all the tools that are needed for the application of the solvent cement and the jointing procedure.

4.3.14 Fix two bolts in two opposite holes of the pump stand flange so that it is possible to tie the rope to them (see also picture of 5.1.4).

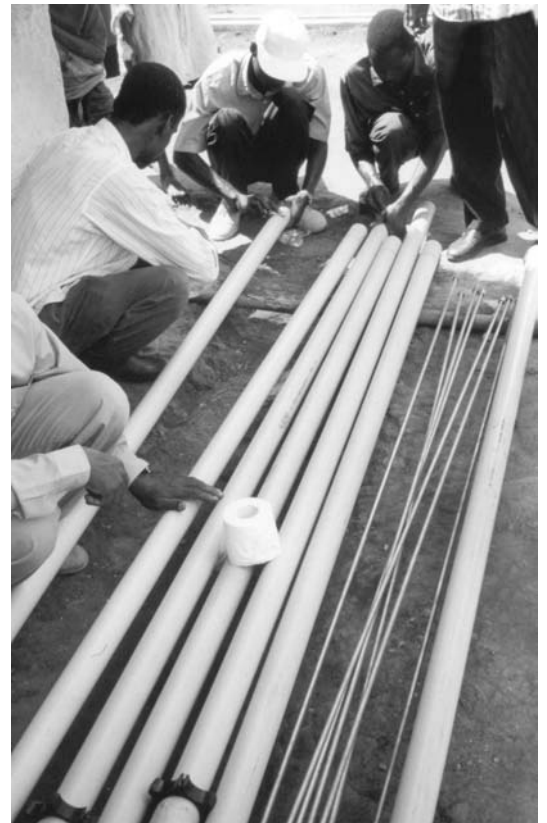

- Note:**
- a) Well chamfered and rounded pipe ends prevent the layer of cement from being removed as the pipe is inserted into the bell-end.
 - b) The mark of the jointing length (115 mm) on the pipe ends makes it possible to check afterwards whether the pipe has been inserted to the full extent of the bell-end.
 - c) The bell-ends of the standard pipes are slightly tapered and designed as such that the pipe cannot be inserted dry into the bell-end. This will only become possible once the cement has been applied.

Do no attempt to make a joint that does not achieve an interference fit when dry. (This can be checked by inserting the spigot into the bell-end before cement is applied – if the pipe end (spigot) slides fully into the bell-end, it will not be possible to cement this joint satisfactorily, so this pipe should not be used here.)

4.4 Important Information for Jointing PVC-U Pipes

4.4.1 Solvent Cement Jointing:

Solvent cement jointing (welding process) of PVC-U pipes offers a simple and quick means of construction high integrity leak-free joints. Correctly made joints are stronger than the pipe itself. The solvent cement operates by chemically softening the outside of the pipe end (spigot) and the inside of the bell-end (socket). Joint integrity is greatly reduced if these surfaces are not absolutely clean and properly prepared.

This fact calls for adequate technical knowledge, clean working conditions and exact preparation procedures. The jointing instructions (see **5.1 Installation of “Down Hole Components”**) are intended to assist all those who are using this technique for the installation of PVC-U rising mains for handpumps.

4.4.2 Clean Working Condition:

As mentioned before, a clean working environment is necessary for receiving strong and leak-free pipe joint results. Without too much of a hassle, the working condition around the well point can be organised as such that clean working is possible. This includes:

- a) Placing PVC-U pipes on logs for preparing/cleaning of joints (in a shady place),
 - b) Placing pumprods on logs near the well (beware of dirt/sand entering threads),
 - c) Cleaning material (Fluid and Toilet paper) and jointing material (solvent cement, bowl and brushes) in a shady, clean and dry place.
- (see also Notes under 5.1.19)

4.4.3 Organised Working:

Since it is of great importance that each jointing process has to be completed within a short period (recommended is 1 minute), the tasks of the installing personnel has to be organised. In order to have sufficient time, it is advisable that the application of solvent cement is made by two persons, one for the pipe ends and one for the bell ends.

3 people are required for pushing the pipes together, one for pushing the bell end over the pipe end and two people for gripping the pipe end, so that stretching of the supporting rope can be reduced.

One person is responsible for the time; he gives the command for starting of solvent cement application and for pushing the pipes together, for keeping the required curing time and he informs the crew when lowering of the joined pipes can start.

4.4.4 Excessive Applications of Solvent Cement:

Do not use excessive solvent cement when preparing for a new joint. A too thick layer of solvent cement will be scraped from the surface when the pipes are pushed together and will lead to a deposit inside the bell-ends. Large deposits inside the bell ends must be avoided as these can weaken the wall of the rising main pipe or might build up as much that the inside diameter of the pipe will be reduced and the plunger will not be able to pass through.

4.4.5 Curing Time for new joints, before next jointing can start:

- a) **Every new pipe joint during installation:**
For any new pipe joint, a curing time of at least 5 minutes is required, before the assembled pipes can be lowered by the ropes and a next joint can be started.
- b) **Last joint at the end of the rising main pipe (Top sleeve):**
The curing time for the top sleeve should be at least 20 minutes, before the completed rising main is lifted for tightening the rope ends to the cone plate (see also 5.1.14).
- c) **Complete rising main before pump is allowed to be operated:**
It is essential that the whole rising main be allowed to cure for at least 12 hours until the maximum load applied can be taken by the joints (operation pressure, weight of water column and stretching of the pipe due to the oscillating movement during operation of the pump).

4.5 Preparation of “Above Ground Components”

- 4.5.1 Assemble the “bearing bush sets” by pressing the bushes together by hand (4 sets per pump).
- 4.5.2 Slip on one centraliser on each pumprod.
- 4.5.3 Keep all prepared rods on a clean place, preferably laid on a stand made of two logs close to the installation spot and make sure that all threads are cleaned from sand or mud.
- 4.5.4 Place all remaining pump components like pump cover and handle parts close to the installation spot and keep the small components like bearings, fulcrum- & hanger pin and all nuts and bolts in the pump head cover.



5.0 Pump Installation Sequences

5.1 Installation of “Down Hole Components”

Note: The joint should be completed in less than 1 minute from the time when the application of cement begins.

5.1.1 Pour an adequate amount of solvent cement into the small bowl and apply a layer of cement to interior surface of the bell-end of the suction pipe and a layer to the cylinder (or spigot) end.

5.1.2 Place the end of the suction pipe on the apron and insert the cylinder in “one go” into the bell-end of the suction pipe.

5.1.3 Remove any surplus solvent immediately with absorbent paper.

5.1.4 After a curing time of at least 5 minutes, insert the suction pipe with cylinder into the pump stand and lower it so that the cylinder top is protruding by about 0.5 m. Then tighten the two ropes on the two prepared bolts on the pump stand flange.

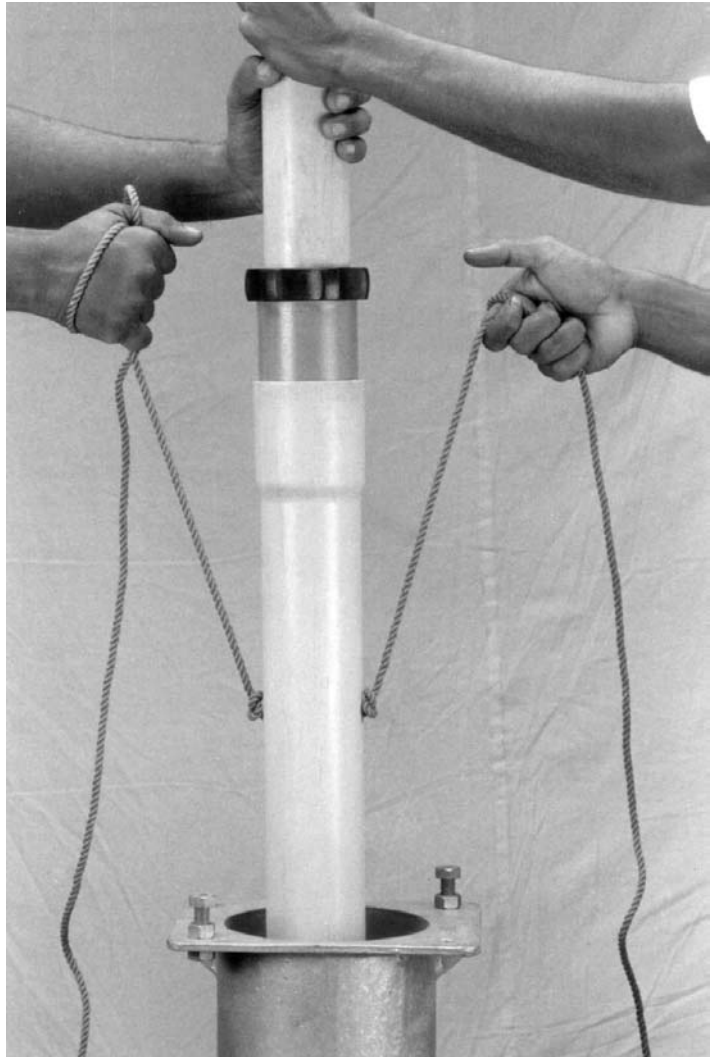

5.1.5 Apply solvent cement to the inside of the bell-end with the smaller brush and at the same time the application to the pipe end of the protruding pipe should be made with the bigger brush. The brush strokes should always be in an axial direction. Ensure that both jointing surfaces are completely covered with a smooth and even layer of cement. (Application time should never exceed 30 seconds for each surface.)

- 5.1.6 Bring the riser pipe into position and push the bell-end **immediately** “in one go” over the protruding pipe until its end position. **Don't twist the newly inserted pipes anymore, as soon as they are pushed together.**

During this strong pushing procedure, the cylinder or the lower pipes needs to be supported by hand (requiring at least two workers), so that the whole force of the “Push” is not taken alone by the fixed rope.

- 5.1.7 Remove any surplus of solvent cement immediately with absorbent paper.

- 5.1.8 Allow the joint to set at least for 5 minutes before loosening the ropes for lowering the pipe into the position for the next joint.

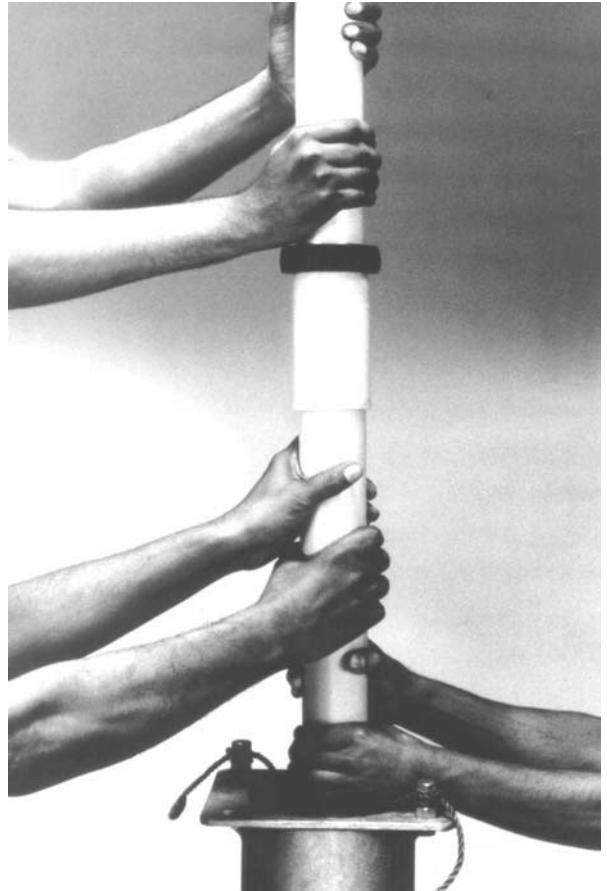

- 5.1.9 When lowering the pipe, place the rope into two opposite grooves of the centralisers and never support or hold the pipe by hand (support only by the two rope ends) since the weight of the pipe should not be taken by the newly made joints.

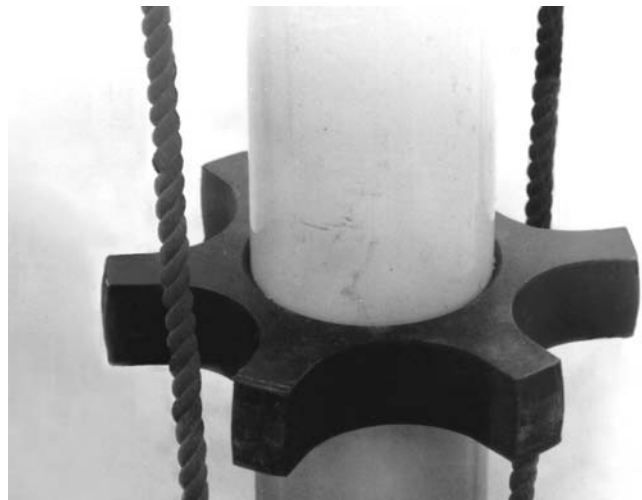

5.1.10 As soon as the pipe is in the required position for the next joint, secure it by fixing the rope to the bolts on the pump stand flange.

This procedure needs to be repeated until the last pipe is connected.



5.1.11 As soon as the last pipe is lowered, the steel cone is inserted and laid to the top flange of the pump stand. Then the rubber cone has to be slid over the pipe, so that the pipe end is protruding (approx. 80 mm).



5.1.12 Clean the protruding pipe end again with cleaning fluid and as soon as it is dry, apply solvent cement to the pipe (80 mm depth) and to the inside of the top sleeve.

5.1.13 Allow the jointed top sleeve to set for at least 20 minutes, before the rubber cone is adjusted and the whole riser pipe is lowered to its final position (in the steel cone).

5.1.14 After the setting time, two person should lift the complete rising main by the steel cone while a third person connects both rope ends to the eyes of the steel cone with two or three securing knots.

5.1.16 When cutting the rope ends, leave at least 1 m excess length (this makes it easy to remove the rising main when retrieving it for making repairs).

5.1.17 Insert the rope ends into the pump stand, lower the whole riser pipe set-up onto the pump stand flange and remove the bolts from the flange.

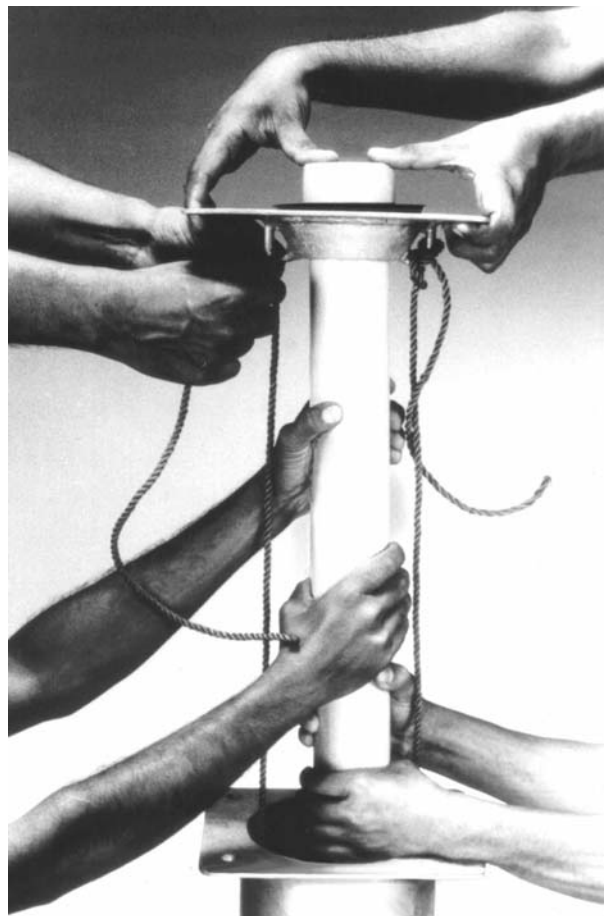
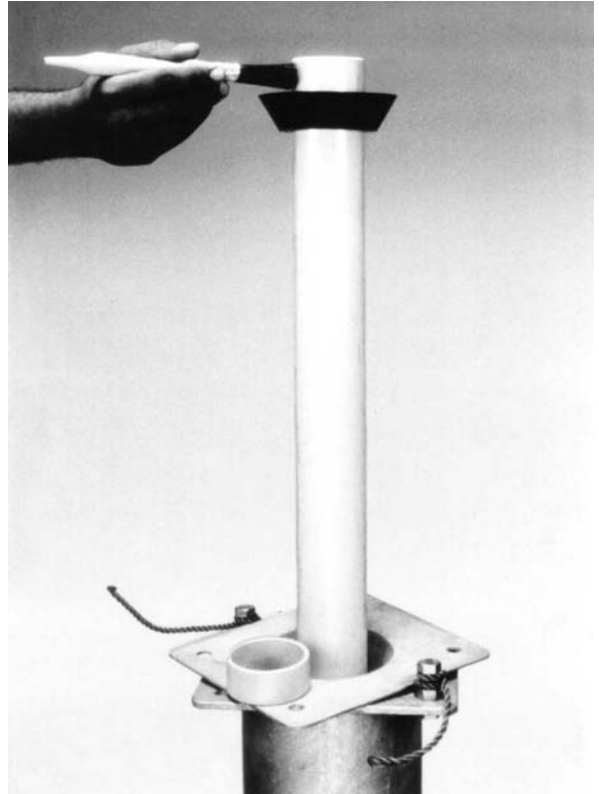

5.1.18 Move the steel cone so that all four holes of the cone plate and the pump stand flange are in line.

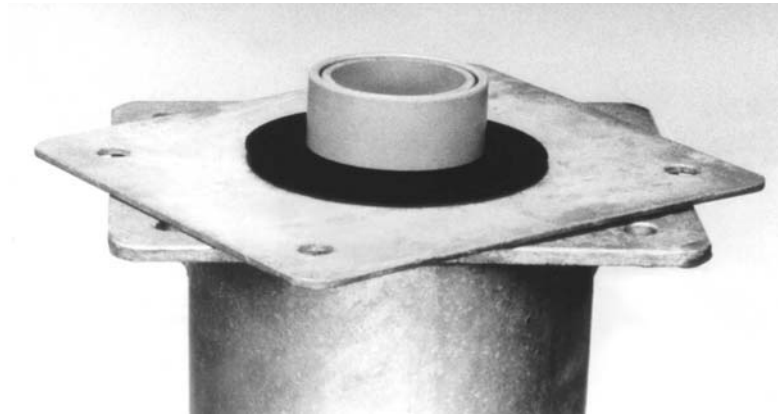

5.1.19 Cover the hole of the rising main to prevent playing children from dropping dirt or stones into the well and let the joints cure for at least 12 hours.

- Note:**
- a) Remove any skin, which may have formed on the cement in the tin.
 - b) Stir the solvent cement thoroughly.
 - c) Solvent cement should have the correct consistency. It should run smoothly from the bottle into the small bowl. Cement that no longer runs smoothly is unusable. Therefore never expose solvent cement to the sunlight and store it in a dry and cool place. (The same applies also to the cleaning fluid.)
 - d) Pour only the approximate amount of solvent cement into the small bowl that is used for the next joint and close the lid of the tin or the bottle immediately after pouring (to prevent the solvent evaporating).
 - e) When applying solvent cement to the inside of the bell-end hold the pipe horizontally and use the smaller brush. Work the cement in well with brush strokes in the axial direction until it forms an even layer.
 - f) Do not use excessive solvent cement and do not dilute or add anything to the solvent cement. Excessive deposits inside the bell-ends must be avoided as these can weaken the wall of the pipe.
 - g) Use a shelter to keep jointing surfaces dry in wet weather.
 - h) Clean the brushes and the bowl with dry absorbent paper after use. Brushes must be dry and flexible before being re-used.

5.2 Installation of “Above Ground Components”

5.2.1 Install pump head on stand assembly and tighten bolts fully.
Now the pump is ready for the installation of the plunger with pumprods.

5.2.2 Attach plunger rod with the plunger and check that the bobbin and the cup seal are in correct position.

5.2.3 Threaded Pumprods

Connect first pumprod to the plunger rod and insert it into the riser pipe. Lower the pumprod assembly and place the **Resting tool** on the Pump head, so that the hexagonal connector is resting in the keyway of the Limiters (see picture).

5.2.4 Lift the pumprod assembly slightly to release the Resting tool, so that the newly fastened connection can pass during lowering of the pumprod assembly.
As soon as the connection has entered the Pump head, the Resting tool can be placed again for preparing the next connection.

5.2.5 Connect following pumprods and make sure that all connections are tightened securely.

5.2.6 After the last rod (Top rod) is connected, lower the completed assembly until the plunger is sitting on top of the footvalve.

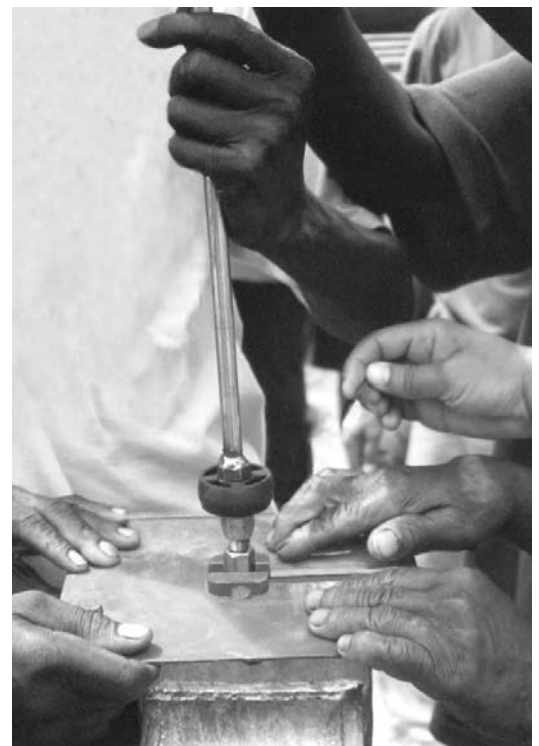
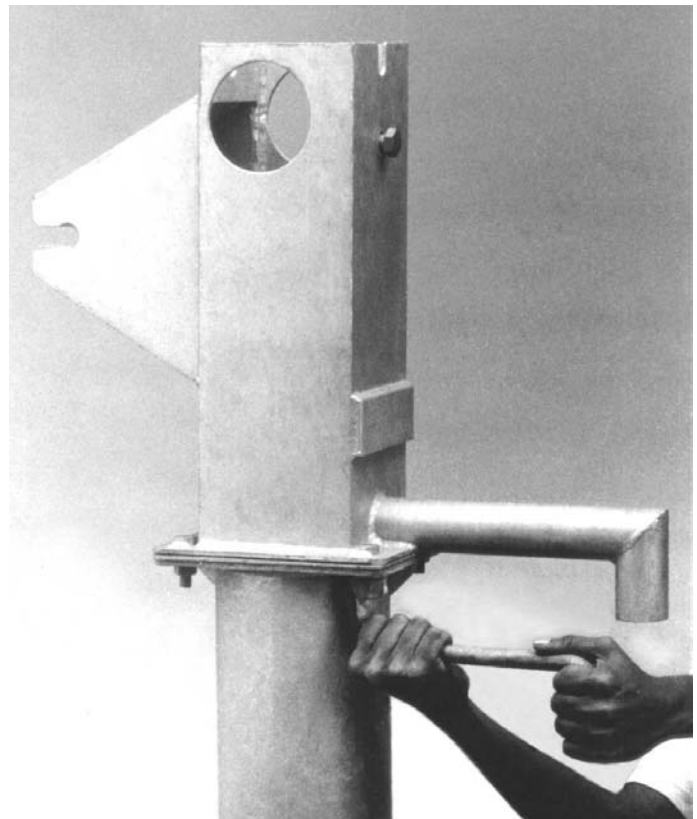

5.2.7 Pumprods with Hooks & Eyes

Connections are made by inserting the Hooks horizontally into the Eyes. Turn the horizontal rod upwards, so that the connection is tight and the rods are exactly in line.

5.2.8 Make sure that the free-hanging pumprod assembly is gripped securely by 2 or 3 people, so that it does not fall into the rising main during this installation procedure.

5.2.9 Connect all pumprod as described until the plunger is sitting on top of the footvalve.

5.2.10 FRP Pumprods

The total weight of FRP Pumprods is about 1/3 of the conventional steel rods and in addition, they are also flexible. Therefore it is easy to connect them outside of the borehole and lower them as a complete assembly.

5.2.11 To determine at what point the Top rod needs to be cut, in order to have the required length, please proceed as follows:

- a) Let the pumprod assembly rest fully, so that the plunger is sitting on top of the footvalve.
- b) Insert one hand into the pump head and grab the protruding pumprod at the top end of the rising main pump and use the thumb for keeping the exact measurement.
- c) Don't loose the grip of the pump rod, when with the help of two or three other people, the complete pumprod assembly is lifted by approximately one meter.

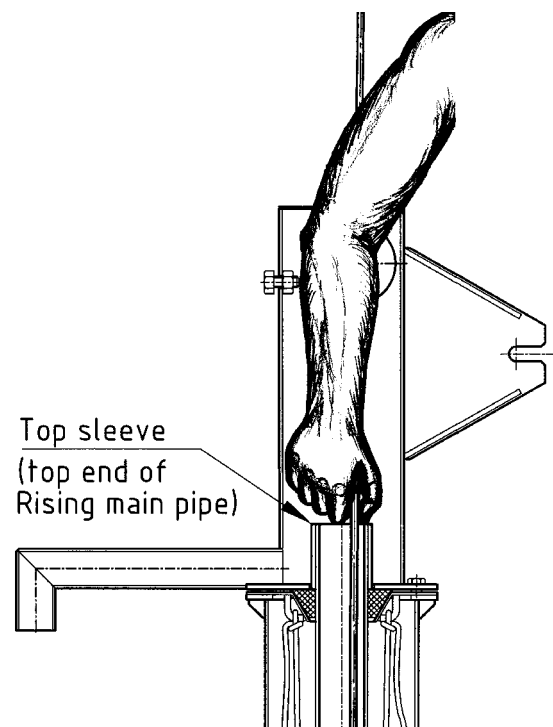
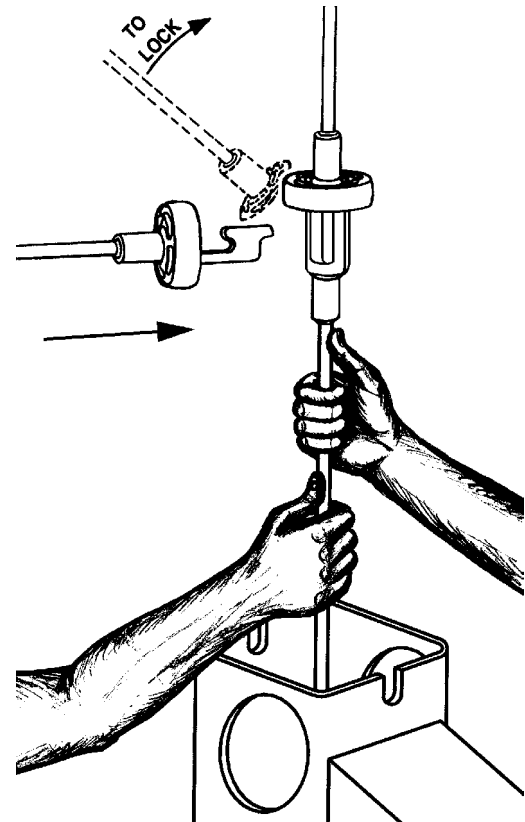

5.2.12 As soon as the hand is outside of the pump head, mark the exact position of the thumb with a permanent marker.

5.2.13 After marking, lift the pumprod assembly as far as to the next connection and disconnect the top rod.

5.2.14 Cut the top rod at the mark and connect it again with the pumprod assembly.

5.2.15 Slip on flapper on the pumprod and fix the rodhanger assembly. Make sure that the rod is inserted to the full extent and that the hexagonal bolt is tightened securely.

5.2.16 Insert the spanner handle into the bush on top of the rodhanger and lower the complete pumprod assembly, so that the spanner handle is resting in the two slots provided in the pump head.

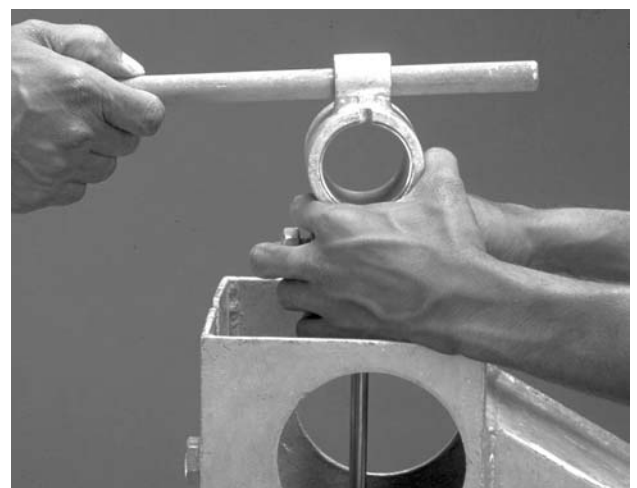
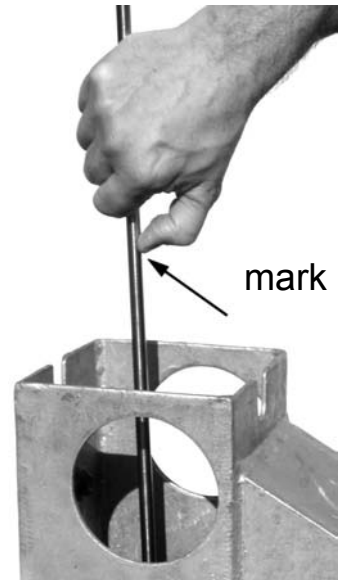

5.2.17 Prior to connecting the handle front assembly, assemble one bearing set with the fulcrum pin and insert it into the fulcrum housing of the handle front. From the other side attach the second bearing set and make sure that lugs are located in the slots of the fulcrum housing.

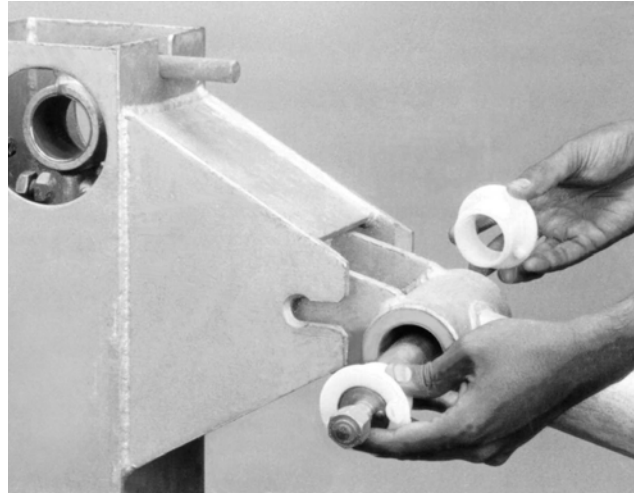

5.2.18 Adjust the lock pins of the fulcrum assembly and the two lugs of the bearing bush inner to the correct position (see sketch). Then, the handle front can be inserted carefully into the slots of the fulcrum bracket.

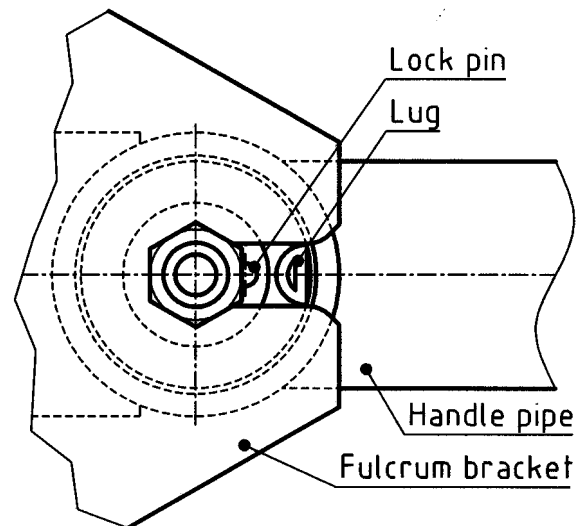

5.2.19 Insert the handle front fully and fasten the special nuts of the fulcrum pin by hand.

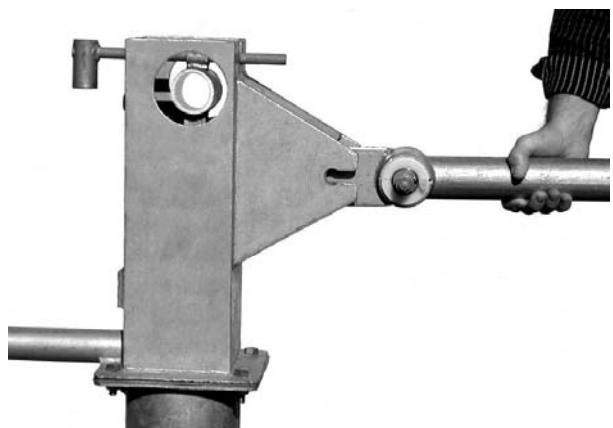

5.2.20 Prior to the next step, make sure that the handle is held securely in horizontal position, in order to avoid pinching of fingers of the person who is assembling the rod housing.

5.2.21 Assemble one bearing set with the rodhanger pin and insert it into the Rodhanger assembly. From the other side attach the second bearing set and make sure that lugs are located in the slots of the hanger bush.

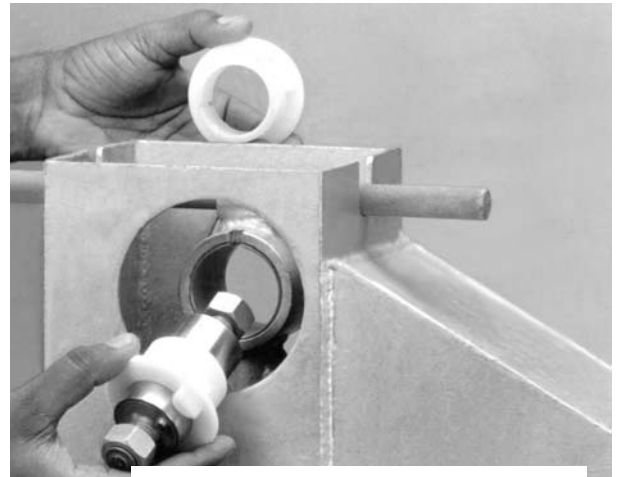

5.2.22 Adjust the lock pins of the rodhanger assembly and the two lugs of the bearing bush inner to the correct position (see sketch), before the handle front can be lowered carefully.

5.2.23 If additional adjustments of lugs and pins are required during insertion into the slots of the handle front, please take care of your fingers.

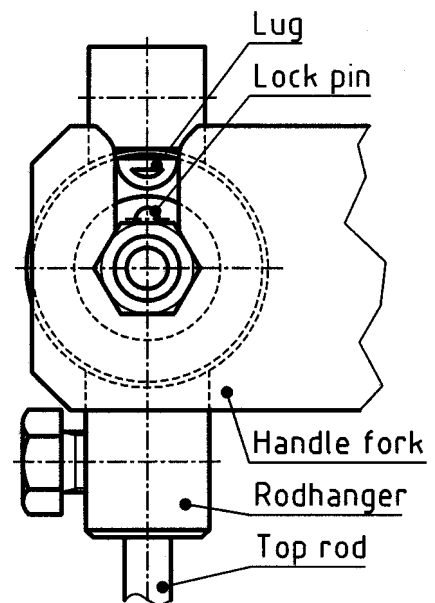

5.2.24 Push down the handle to its lowest position and remove the

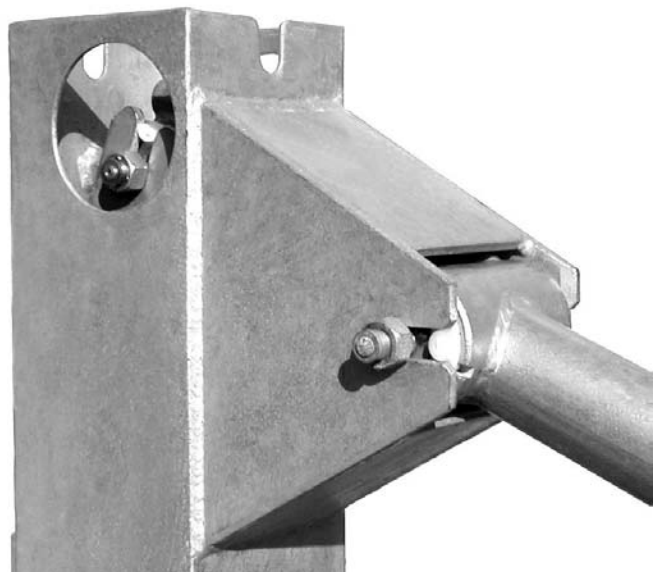

5.2.25 Prior to fastening the nuts of the fulcrum- and hanger pin, make sure that they are in correct position. Tighten nuts securely.

5.2.26 Insert the handle rear assembly into the handle front assembly as such that the handle is balanced correctly (remains in horizontal position). Tighten adjustment bolt securely.

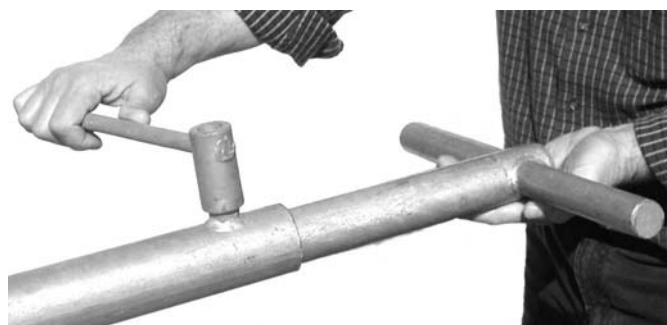

5.2.27 Operate the handle till the water flows out of the spout. The number of strokes required until full flow is reached, is determined by the installation depth of the cylinder (the installation depth divided by the maximal handle stroke indicates approximately the number of full strokes required). Due to the slightly bigger diameter of the riser pipes, **about six full strokes** are required for **lifting the water by 1 m**.

5.2.28 Initially the first water might be turbid and smelling from chlorine, but after 15 to 30 minutes of operation it should become clear.

5.2.29 Now the following checks should be carried out:

- a) All nuts and bolts are well secured.
- b) Effort required to operate the pump is normal.
- c) There is no leakage in the rising main (wait for 5 minutes to see whether water in the rising main recedes).
- d) Water discharge (approx. 40 strokes per minute) is above 16 liters.
- e) Identification mark on the pump for easy location by the support agency is painted or stamped.

5.2.30 Fill in the installation card (Annex 5a). A copy of the completed card should be given to the users committee or handpump caretaker.

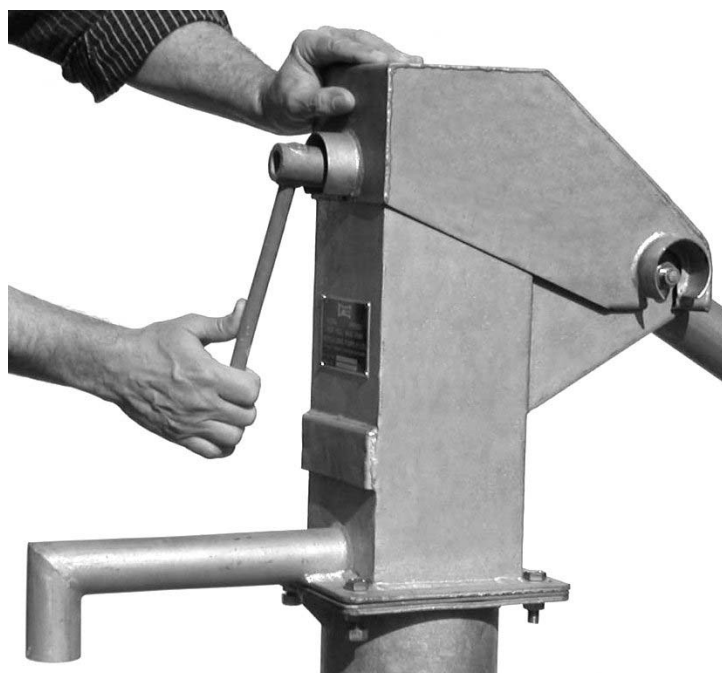

5.2.31 Fix the cover and tighten the cover bolt.

5.2.32 Inform the caretakers and users to wait until the next day and then pump for about 30 minutes, to make sure that bleaching powder solution is pumped out completely.

5.2.33 Check whether caretakers or users are aware of the preventive maintenance required.

5.2.34 Check whether caretakers or users are informed where to get spare parts and whom to contact, if the pump needs repair.

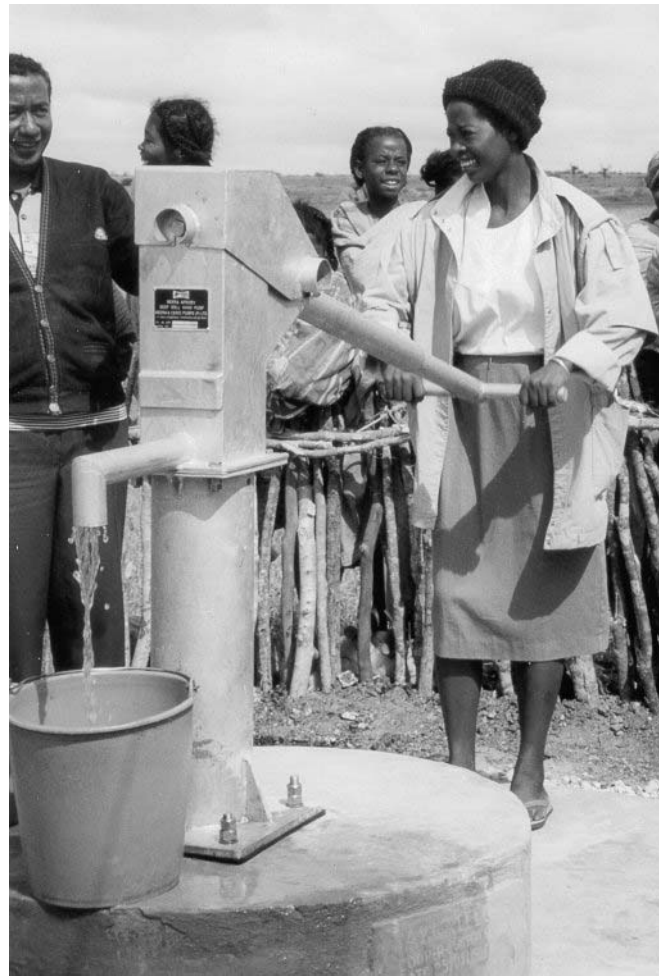

Part 2 Maintenance of the Afridev Handpump

6.0 Preventive Maintenance

Every pump owner, caretaker or the user committee is responsible for the preventive maintenance of the water point (handpump including surrounding) and therefore is entitled to receive regular training from the supplier of the handpump.

Preventive maintenance means regular check-up of the handpump at a fixed time interval and changing of spare parts before they are fully worn.

As an example; if the estimated lifetime of a plunger seal is one year, the plunger seal will be changed after a period of one year even if it is still functional. If during a preventive maintenance check, footvalve leakage is noticed, the caretaker will carry out repairs in the footvalve even though the pump has not broken down.

Such interventions help in preventing the sudden failure of the pump.

6.1 Preventive Maintenance Checks of Handpump

6.1.1 Tree monthly checks:

- Check if any fasteners or parts in the pump head are missing. If so, replace the parts.
- If any unusual noise is noticed, check reason for the same and take corrective actions.
- Check if the pump stand is shaky during operation. If yes, the stand is loose in the foundation and contamination of the well can take place. Take corrective measures to repair the foundation.
- Check if there is leakage in the pump. If more than 5 strokes are required before water comes out from the spout, it means the pump is leaking beyond an acceptable limit. This needs to be attended to. It may be necessary to replace Bobbin / Footvalve O-ring or attend to a leaking joint in the rising main. For attending to a defect in the rising main you may need the help of a skilled mechanic. The special leakage test can be conducted as described below.

6.1.2 Leakage test:

Testing shall start after a continuous flow of water through the spout has been obtained. The water shall then be collected in a container or bucket for 40 continuous full strokes of the plunger in one minute. Measure the quantity of water collected. Then allow the pump to rest for 30 minutes. Repeat the test and measure the discharge. The difference between the first and second reading of discharge indicates leakage. Also note the number of strokes required before water comes out of the spout. If after the break of 30 minutes it needs more than 5 strokes until the water starts flowing, it is an indication that there is a leakage and it is advisable to take corrective action.

6.1.3 Checking the discharge:

If the discharge is less than 10 litres for 40 strokes, there may be a need to change the plunger seal / bobbin or the footvalve O-ring.

6.1.4 Discharge test:

Testing shall start after a continuous flow of water through the spout has been obtained. The water shall then be collected in a container or bucket for 40 continuous full strokes of the plunger in approximately one minute. The water collected should be generally not less than 16 litres.

6.2 Maintenance of Pump Surrounding

Handpumps with platforms offer a good protection, because they seal off the well from external sources of contamination. However, even when handpumps are fitted, contaminations can still pollute the well through:

- a) Cracked platforms and drainage channel
- b) Stagnant water near the well
- c) Animals (and human) excrements too close to the well (no fence)
- d) Waste and other sources of contamination too close to the well

It is the important task of the Handpump Caretaker to:

- 1.) check the platform for cracks and do the necessary repair,
- 2.) eliminate stagnant water by filling the dents and holes with earth,
- 3.) maintain the fence around the water point, so that no animals have access,
- 4.) keep the surroundings clean and tidy at all times.
- 5.) instruct the pump users how to use the pump and how to keep the pump surroundings clean.

(See also 3.1.2 Well siting and 3.1.3 Hygiene Education and Water Supply.)



7.0 Maintenance of Handpump

The handpump is like any other mechanical device and needs maintenance to keep it in good working condition. It has been observed that the maintenance in community handpumps is very often “Breakdown-based”.

In the absence of preventive maintenance, sudden breakdown of handpumps and disruption in water supply do occur. The danger of abrupt breakdown of the pump can be minimized if preventive maintenance is carried out.

The steps involved in maintenance are to:

- a) Understand the cause for a problem and determine the remedy need.
- b) Dismantle the pump as necessary.
- c) Assemble the pump after replacing defective components.
- d) Record details in the “Maintenance card” (see Annex V.b).

7.1 Diagnosis of Handpump Problems

To identify the cause for a problem and remedy needed, please refer to the “Trouble Shooting Chart (Annex I.) This chart lists general operational problems, their causes and remedies.

7.2 Tools and Spare Parts required for Handpump Maintenance

7.2.1 The basic tools required for handpump maintenance are:

- a) Spanner for M16 hexagonal bolts and nuts (B2160)
- b) Fishing tool for retrieving of Footvalve (B2150)

For deep installations (between 30 to 45 m) with a heavy load of the Pumprod assembly, the use of Resting tool B2415 & Connecting tool B2420 is advisable (for threaded rods only).

7.2.2 The “List of Spare Parts for AFRIDEV Handpumps” is given in Annex II (see also “Replacement Interval of AFRIDEV Wearing Parts” in Annex III).

7.3 Procedure of Dismantling “Above Ground Components”

7.3.1 Loosen pump cover bolt and remove the cover.

7.3.2 Loosen hanger pin nuts and fulcrum pin nuts fully.

7.3.3 Move the pump handle to the lowest position and insert spanner handle into the rodhanger bush. Move the pump handle slowly upwards and guide the spanner handle into the two slots provided at the pump head.

7.3.4 As soon as the rodhanger is hanging freely, pull out the handle carefully (horizontal).

7.3.5 Remove the fulcrum pin and the bearing bush sets from the handle.

7.3.6 Remove the hanger pin and the bearing bush sets from the rodhanger.

7.3.7 Place all small components (fulcrum pin, hanger pin, bearing bushes etc.) inside the pump head cover to prevent that they get dirty.

7.4 Dismantling Threaded Pumprods (including Plunger and fishing of Footvalve)

- 7.4.1 Take an additional pumprod and attach the Connecting tool.
- 7.4.2 Pull out the Top rod with Rodhanger and disconnect the first joint.
- 7.4.3 Connect the additional pumprod with the Connecting tool and lower the whole assembly slowly until the Plunger rests on the Footvalve.
- 7.4.4 Take the T-bar of the Connecting tool and turn it clockwise for 3 complete revolutions.
- 7.4.5 The Footvalve is now connected and the removal of the whole assembly can start.
- 7.4.6 Remove all Pumprods "one by one" until the Plunger rod with Plunger and Footvalve is released. Make sure that all rods are neatly placed near the pump and are in a clean place.

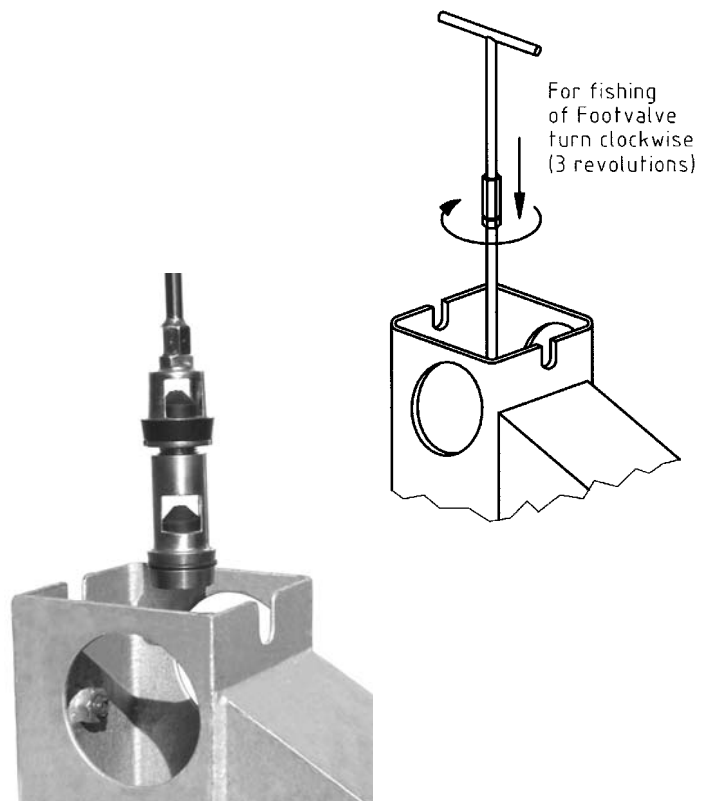

7.5 Re-installing Threaded Pumprods (including placing of Footvalve)

- 7.5.1 Attach the Footvalve to the Plunger (max. 3 revolutions) and connect Plunger rod and all Pumprods.
- 7.5.2 Instead of the Top rod, connect an additional pumprod with Connecting tool.
- 7.5.3 After the Footvalve is sitting firm in the conus of the Footvalve receiver (cylinder), turn the T-handle of the Connecting tool anti-clockwise for approximately 6 revolutions.
- 7.5.4 Lift the Pumprod assembly as much that the additional Pumprod and Connecting tool can be replaced by the Top rod and Rod hanger.
- 7.5.5 Insert the Spanner handle into the bush of the Rodhanger and let the assembly rest in the two slots provided in the Pump head.

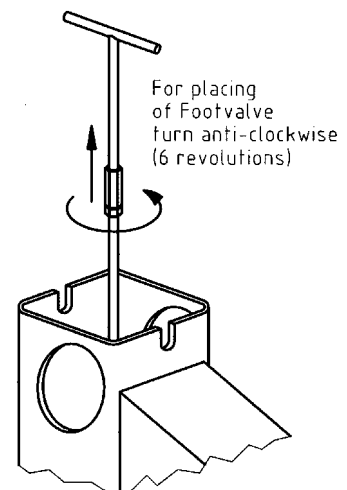

7.6 Dismantling Hook & Eye Pumprods (including Plunger and fishing of Footvalve)

- 7.6.1 Pull out the Top rod with Rodhanger and disconnect the first joint.
- 7.6.2 Remove all pumprods "one by one" until the Plunger rod with Plunger is released.
- 7.6.3 Remove Plunger rod and Plunger from the last Pumprod and replace them with the Fishing tool.
- 7.6.4 Re-install all Pumprods "one by one" until the Fishing tool is resting on top of the Footvalve.
- 7.6.5 Turn the Pumprod assembly slightly so that the hook of the Fishing tool connects with the Footvalve assembly.
- 7.6.6 Remove all Pumprods "one by one" until the rods with Fishing tool and Footvalve are released.
- 7.6.7 Make sure that all rods are neatly placed near the pump and are in a clean place.

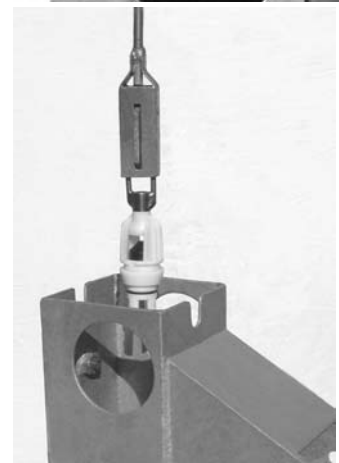
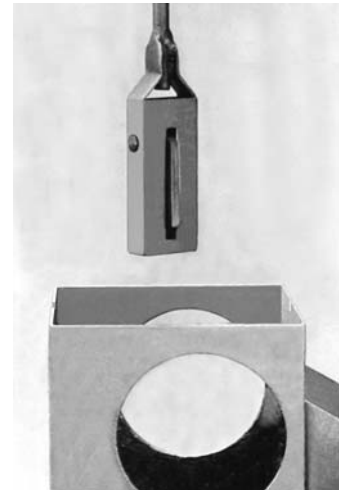

7.7 Re-installing Hook & Eye Pumprods (including placing of Footvalve)

- 7.7.1 Drop the Plastic Footvalve into the Rising main pipe.
- 7.7.2 Re-install Plunger, Plunger rod and all Pumprods.
- 7.7.3 Attach an additional Pumprod with the Connecting tool and push the Footvalve gently in correct position.
- 7.7.4 Lift the Pumprod assembly as much that the additional Pumprod with Connecting tool can be replaced by the Top rod and Rod hanger.
- 7.7.5 Insert the Spanner handle into the bush of the Rodhanger and let the assembly rest in the two slots provided in the Pump head.

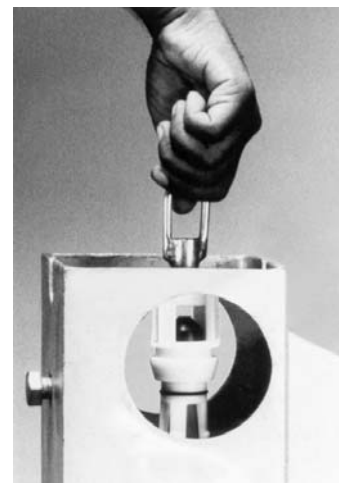

7.8 Dismantling and Re-installing FRP Pumprods (including Plunger and fishing of Footvalve)

- 7.8.1 The advantage of FRP Pumprods (FRP = Fibre Reinforced Plastic) is that once installed, the whole pumprod assembly can be pulled out of the rising main, without disconnecting the single rods. Therefore the time for retrieving of a pumprod assembly is a matter of 1 or 2 minutes. Since the total weight of an pumprod assembly with FRP pumprods is roughly only 1/3 of the weight of a pumprod assembly of steel, removal of the assembly is very easy.



- 7.8.2 The procedure for retrieving and placing of the footvalve depends on the set-up of the plunger and footvalve (see Plunger/Footvalve options on page XX).

7.9 Re-assembling “Above Ground Components”

- 7.9.1 Place Fulcrum pin with Bearing bushes in the Fulcrum bush.
- 7.9.2 Align the Lock pins and the lugs of the Bearing bushes and insert handle assembly into the Pump head. Tighten the hexagonal nuts by hand.
- 7.9.3 Keep Pump handle horizontal and place Hanger pin with Bearing bushes in Rodhanger assembly.
- 7.9.4 Align the Lock pins and the lugs of the Bearing bushes and move the T-bar of the Handle assembly slowly downwards, so that the Rodhanger pin ends are slipping into the slots of the Handle forks. Tighten the hexagonal nuts by hand.
- 7.9.5 Press the Handle assembly to its lowest position and release the Spanner from the bush on top of the Rodhanger assembly.
- 7.9.6 Tighten the Fulcrum pin- and Rodhanger pin nuts securely with the Spanner.
- 7.9.7 Operate the pump and check the discharge and leakage.
- 7.9.8 Attach the Pump cover and secure it by tighten the cover bolt.

(For more information see also No. 5.3 of the installation part.)

8.0 Repair of Handpump

Major repairs such as the replacement of the rising main or retrieve of dropped components are beyond the capacity of the handpump caretaker and therefore will need to be carried out by a skilled mechanic.

8.1 Pulling out the whole Rising main

It may be necessary to repair the rising main when there is a leakage due to a crack or perforation or due to a leaking joint.

The exercise will need at least eight persons to pull out the whole length of the rising main, make sure that the pipe is well supported (see sketch below). If this is not done, the joints of the rising main may get cracked or the pipe might break.

While pulling out the rising main, mark places where there is a leakage.

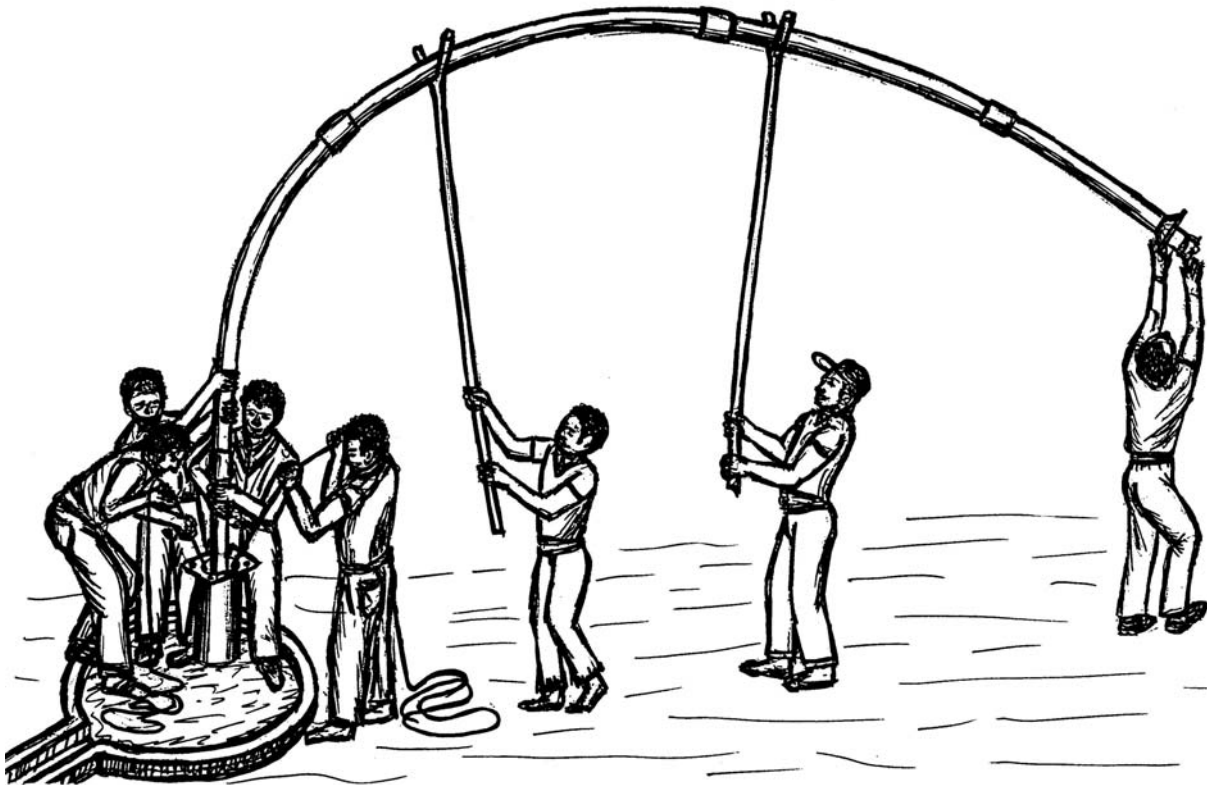

8.2 Fitting of Repair Sockets

After the rising main has been pulled out, examine it carefully and retrieve dropped components or carry out repairs. For this purpose a "Repair piece" with bell-ends at both sides will be needed, see sketch below.

(the technical drawing for manufacturing Repair Sockets can be found in Annex VII.)

Cut the affected portion in such a way, that the total length of the rising main remains the same after jointing the Repair piece.

Follow the instructions given in **Annex II** while making a PVC-U joint and **do not forget to provide support to the rising main while putting it back into the borehole.**

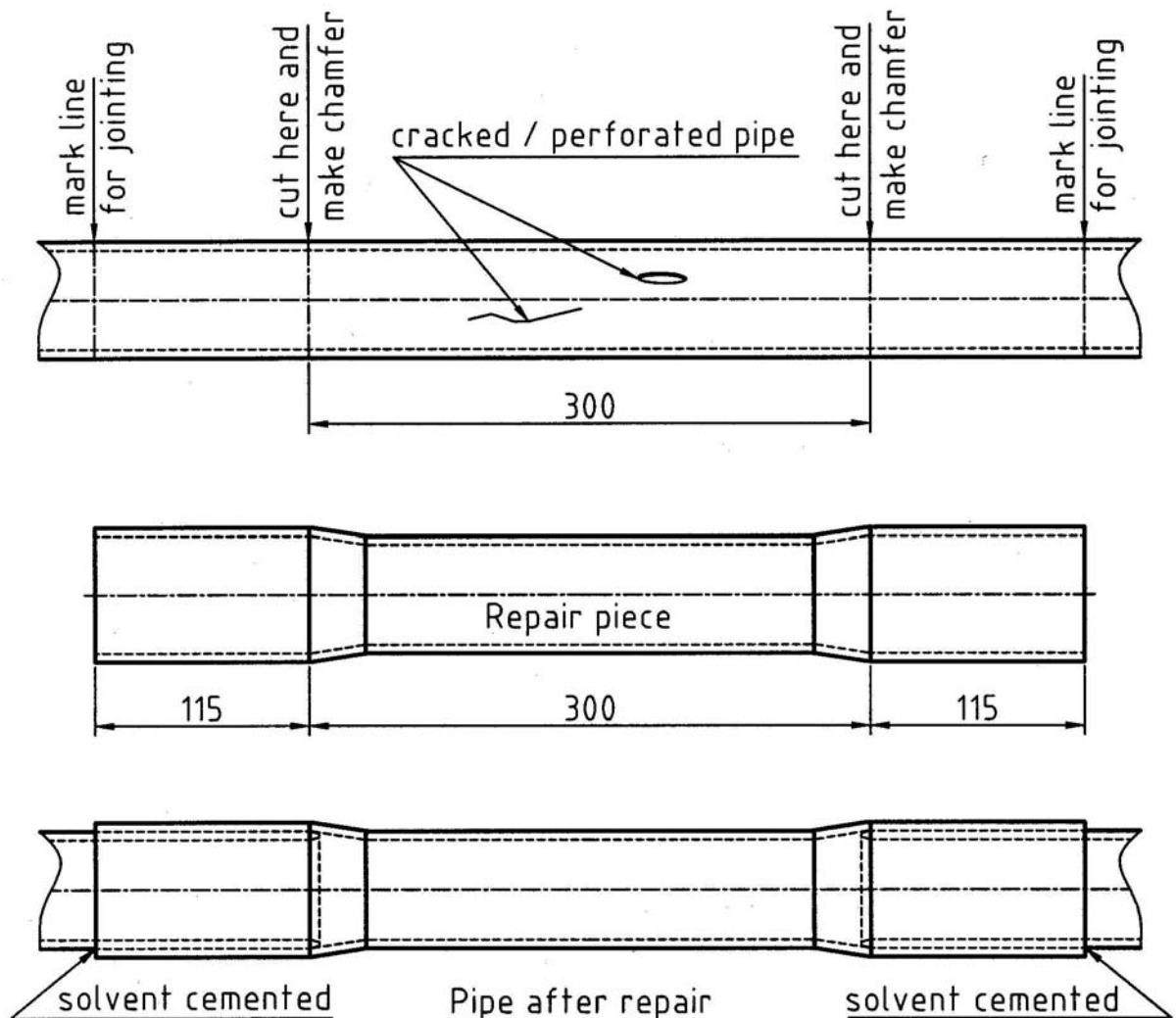

8.3 Fishing of Dropped Handpump Parts

During installation or maintenance activities, handpump components might fall into the well. Retrieving dropped components like a Rising main from a Dugwell is not a problem, whereas fishing of dropped parts in a Boreholes can be a difficult and time consuming task.

Therefore some special tools have been developed, in order to assist any fishing attempts. The assembly drawings of the “Fishing tools” can be found in Annex VI.

Detail drawings for manufacturing of the developed Fishing tools are available on request.

9.0 Recording of any Intervention

It is advisable to collect and record any data of a well, starting from digging or drilling, platform construction, installation of a handpump including all Maintenance and Repair interventions during the lifetime of the handpump and the well (like a “log-book” on a ship).

Besides Installation and Monitoring details, make the necessary entries of Maintenance and Repair in the documents of each pump. The information to be recorded will include date of breakdown, date of repair, nature of complaint, parts replaced and kind of repair or any other important observations. (see also “Examples for Recording of any Intervention” in Annex V).

Annex I

Trouble Shooting Chart for AFRIDEV Handpumps

Annex II

List of Spare Parts for AFRIDEV Handpumps

Annex III

Replacement Interval of AFRIDEV Wearing Parts

Annex IV

Correct Storage of AFRIDEV Handpump Components

Annex V

Example for Recording of any Intervention

- a) Installation Card
- b) Maintenance Card
- c) Monitoring Card

Annex VI

Drawings of Fishing Tools for dropped Handpump Parts

- a) For Fishing disconnected Pumprods
- b) For Fishing broken Pumprods
- c) For Fishing disconnected or broken Riser Pipes

Annex VII

Technical Drawing of Repair Socket